

NAXSO



WHY NAXSO LIGHTING BUSBAR

A- HOUSING IS ALUMINIUM MADE WITH ONE EXTRUDED UNASSEMBLED PART INSTEAD OF TWO. THIS MEANS AN EXCEPTIONAL STRENGTH AGAINST ANY "HELIX" OR "WAVE" EFFECT. THE BUSBAR IS STURDY, RIGID AND STIFF.



TWIST

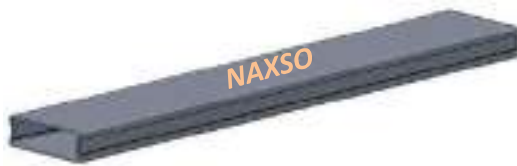

FOLD

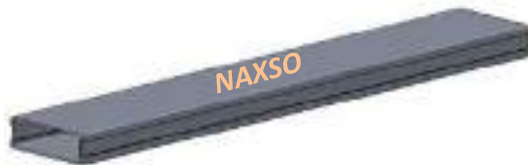

B- ALUMINIUM BODY MAKES THE BUSBAR EXTREMELY LIGHT WEIGHT.



C NAXSO LIGHTING BUSBARS HAVE UP TO 6 CONDUCTORS CAPACITY PLUS ...

- THE CONDUCTORS ARE 690 VOLTS.
- ANY CIRCUIT CAN BE WIRED BOTH ENERGY AND SIGNAL AS WELL AS DALI AND BUS CONTROLS UP TO 40 JOINTS (120 MT).
- ALL THE TAP OFFS HAVE UP TO 6 PINS CAPACITY FOR EVERY SINGLE TAP OFF AND THE BIG ONE (SBM) CAN EVEN BE FUSED UP TO 25A.

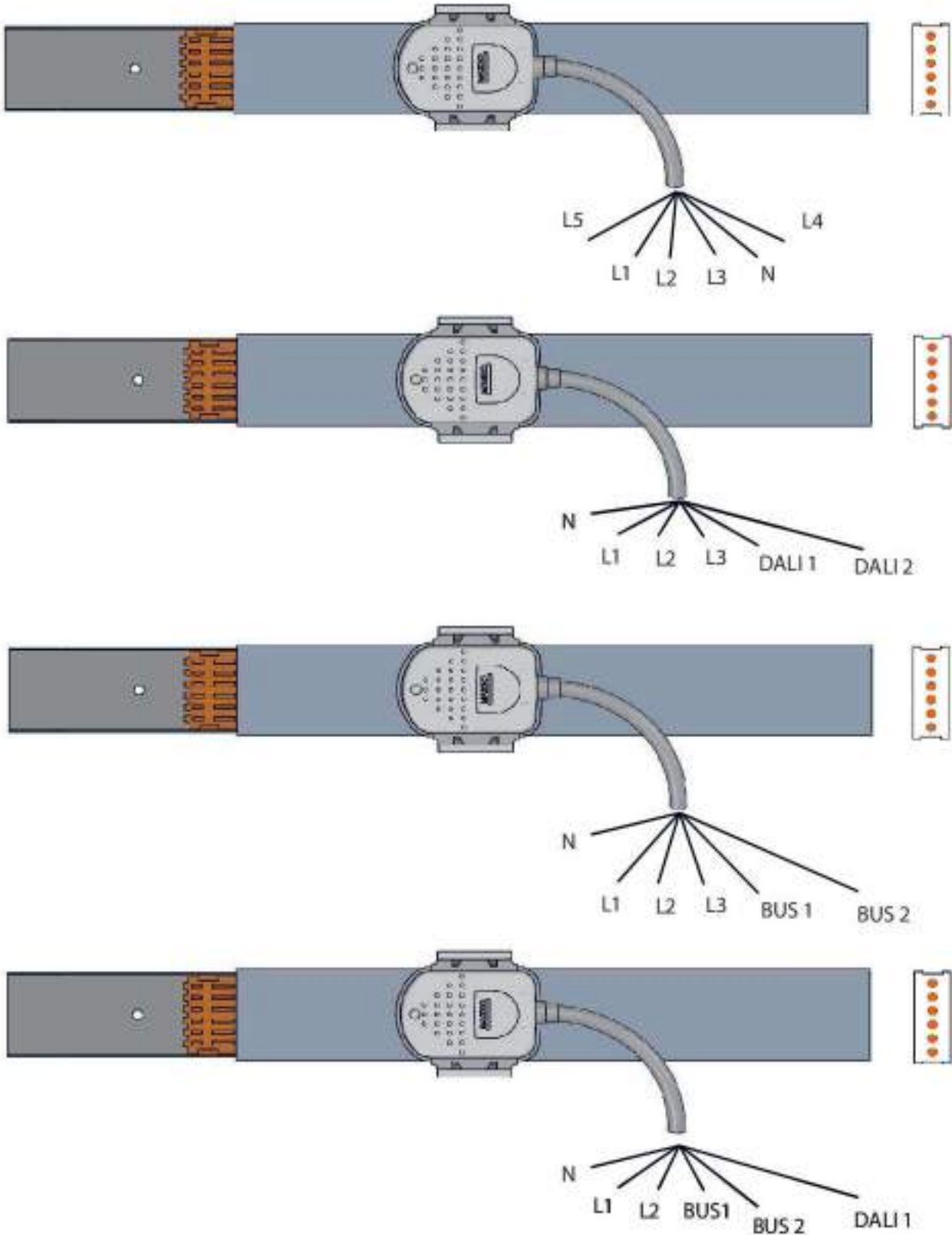

- D-** ALUMINIUM BODY MEANS EXCELLENT PE CONDUCTOR 130 mm² AROUND 90 mm² COPPER EQUIVALENT.
- NO EXTRA PE IS NECESSARY.
 - PE HOUSE RESULTS IN LOW NOISE MATERIAL.
 - THE ELECTRICAL MAGNETIC FIELD IS ROUGHLY ZERO.

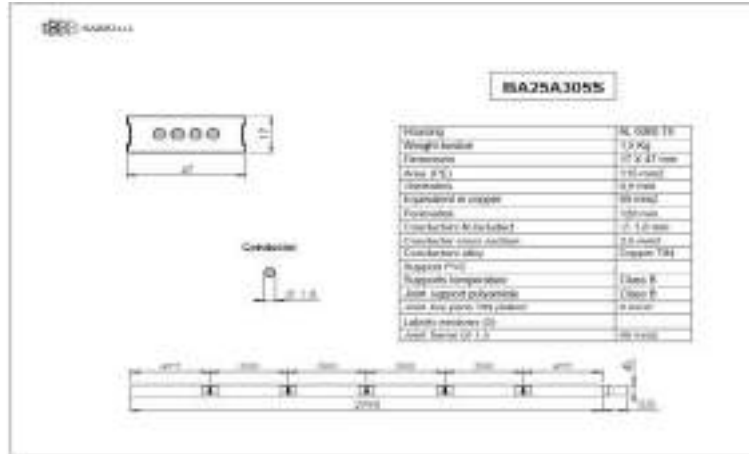

- E-** THE NAXSO BUSBAR HAS INCREASED CONDUCTIVITY BECAUSE OF THE ALUMINIUM 1-PIECE CASE COMPARED TO 2-PIECE STEEL HOUSING OF THE COMPETITORS.





NAXSOLUX



Naxso lighting busbar is an aluminium extruded very strong and light busbar track with a number of ratings 25-40-63A and assembled tracks mono busbar and double side back to back to ensure COMPLETE SEGREGATION when needed for safety reasons. Naxso lighting is the only lighting busbar in the market with six conductors in one housing so that when is double we can offer 6+6 conductors. All naxso tap-offs can be wired and connected to all six conductors both with or without fuses and enormous number of choices is offered and all the tap offs are rewirable.





Il Naxsolux è un estruso di alluminio molto robusto e leggero da 25-40-63A. Una versatilità che si rivela nella possibilità di accostare due condotti garantendo totale segregazione per ragioni di sicurezza.

Il Naxsolux è l'unico prodotto sul mercato con 6 conduttori in un solo involucro che su richiesta di accostamento delle barre diventano 6+6. Tutte le spine Naxso possono essere cablate e connesse a tutti i conduttori sia con o senza il fusibile con una vastissima gamma di opzioni. Tutte le spine sono ricabliabili.



SINGLE BUSBAR AND DOUBLE BUSBAR LIGHTING

SINGLE BUSBAR LIGHTING

- 25A 2 CONDUCTORS
- 25A 4 CONDUCTORS
- 25A 6 CONDUCTORS
- 40A 2 CONDUCTORS
- 40A 4 CONDUCTORS
- 40A 6 CONDUCTORS
- 63A 2 CONDUCTORS
- 63A 4 CONDUCTORS
- 63A 6 CONDUCTORS

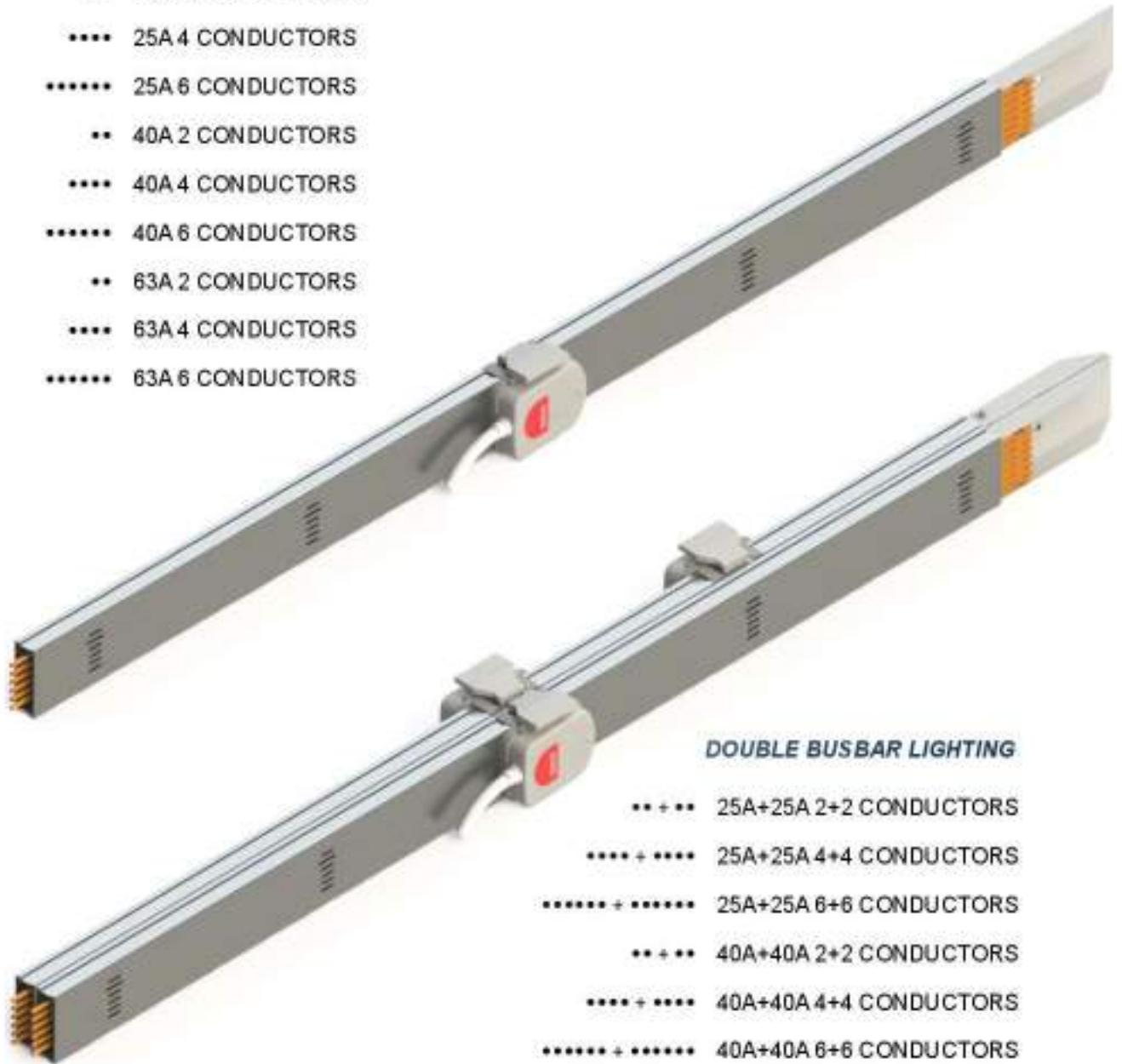

DOUBLE BUSBAR LIGHTING

- + •• 25A+25A 2+2 CONDUCTORS
- + •••• 25A+25A 4+4 CONDUCTORS
- + ••••• 25A+25A 6+6 CONDUCTORS
- + •• 40A+40A 2+2 CONDUCTORS
- + •••• 40A+40A 4+4 CONDUCTORS
- + ••••• 40A+40A 6+6 CONDUCTORS
- + •• 63A+63A 2+2 CONDUCTORS
- + •••• 63A+63A 4+4 CONDUCTORS
- + ••••• 63A+63A 6+6 CONDUCTORS

N.B. : NEL DOPPIO CANALE VI E' LA POSSIBILITA' DI UNIRE ASSIEME BARRE CON DIFFERENTI NUMERI DI CONDUTTORI (AD ESEMPIO: 2+4, 4+6, 2+6, ECC.)

N.B. : IN DOUBLE BUSBARS ARE POSSIBLE TO COMBINED THE BUSBARS WITH DIFFERENT NUMBERS OF CONDUCTORS (FOR EXAMPLE: 2+4, 4+6, 2+6, ECC.)

COMPATIBILITY TAP-OFF ON BUSBAR

LIGHTING

25A
40A
63A



TAP OFF					
MODEL	CODE	RATING (A)	CABLE	NO CABLE	FUSED
MOUSE	SM-N	10-16-20	X	X	
BIG MOUSE	SBM	6-16-20-32	X	X	X
SFIP	SFIPN	6-16	X	X	X
CAT	CATLUX	16-25-32		X	X

POWER

40A
63A
100A
160A
250A



TAP OFF					
MODEL	CODE	RATING (A)	EMPTY	EMPTY FOR MCCB	FUSED
CAT	CAT	32	X	X	X
SUPERCAT	SUPERCAT	32-50-100-125	X	X	X
STAR	STAR	63-100-125	X	X	X

POWER

250A
400A
630A
800A
1000A

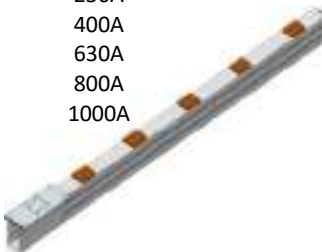

TAP OFF					
MODEL	CODE	RATING (A)	EMPTY	EMPTY FOR MCCB	FUSED
CAT	CAT	32	X	X	X
SUPERCAT	SUPERCAT	32-50-100-125	X	X	X
STAR	STAR	63-100-125-160-250	X	X	X

POWERSANDWICH

1250A
1600A
2000A
2500A
3200A
4000A
5000A
6300A

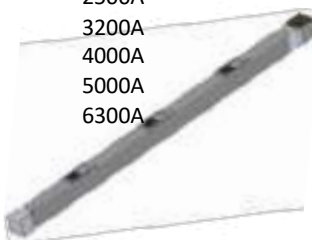

TAP OFF					
MODEL	CODE	RATING (A)	EMPTY	EMPTY FOR MCCB	FUSED
STAR	STARPXW	50-100-160-250 400-630-800-1000	X	X	X

CONDUCTORS CROSS SECTION mm²		
BUSBAR	ALUMINIUM	COPPER
<i>LIGHTING (BA)</i>		
25A	ONLY IN COPPER	2,5
40A	ONLY IN COPPER	6
63A	ONLY IN COPPER	6,7
<i>POWER (BP)</i>		
40A	36	15
63A	40	18
100A	45	40
160A	65	60
250A	120	70
<i>POWER (BPG)</i>		
250A	216	75
400A	271	100
630A	379	165
800A	515	220
1000A	665	330
1250A	ONLY IN COPPER	440
<i>POWERSANDWICH (PXW)</i>		
1250A	850	450
1600A	1104	600
2000A	1354	750
2500A	1577	960
3200A	1827	600 x2
4000A	1354 x2	750 x2
5000A	1577 x2	960 x2
6300A	1827 x2	ONLY IN ALUMINIUM



SM TAP-OFF OUTLETS 6 SLOTS
Attacchi spina 6 uscite

SFIP

SBM

SBMBOX

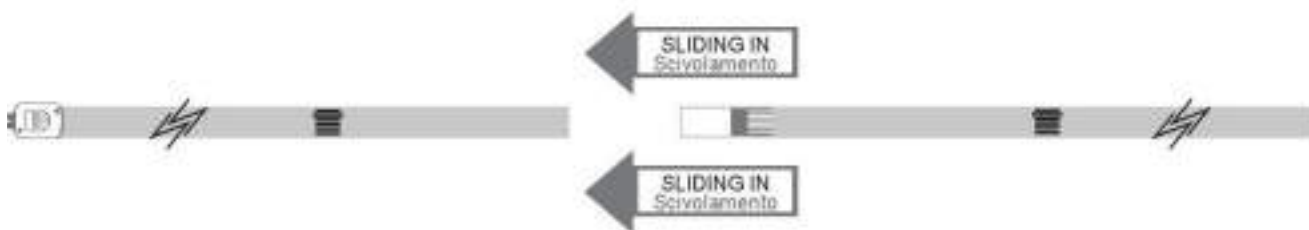
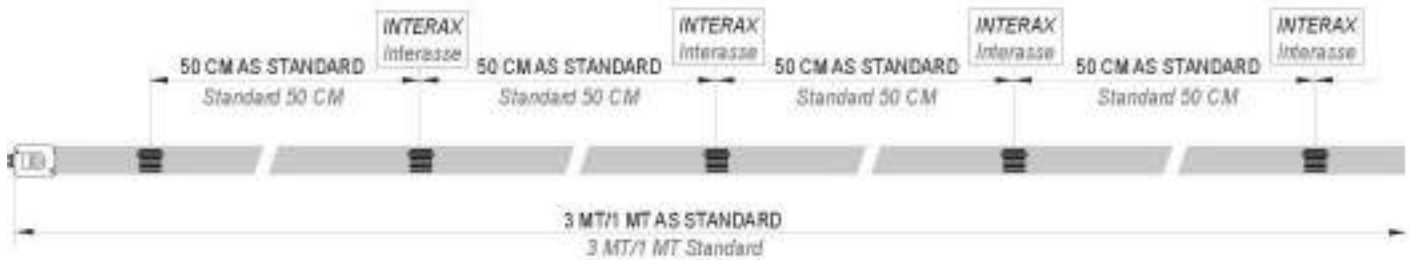

A	PART NUMBER	POLE	WEIGHT
25A	BA25A305S	3P+N+PE (HOUSING)	0,55 Kg/mt
25A	BA25A3065S	5P+N+PE (HOUSING)	0,70 Kg/mt
40A	BA40A305S	3P+N+PE (HOUSING)	0,70 Kg/mt
40A	BA40A3065S	5P+N+PE (HOUSING)	0,80 Kg/mt
63A	BA63A305S	3P+N+PE (HOUSING)	1,10 Kg/mt
63A	BA63A3065S	5P+N+PE (HOUSING)	1,40 Kg/mt

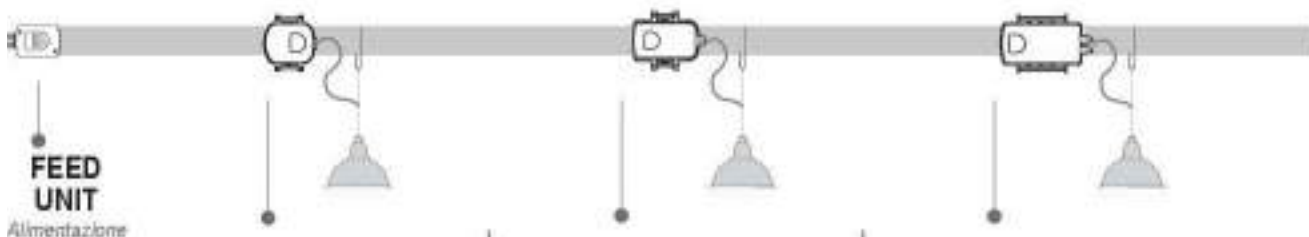

SM
SMALL TAP-OFF
Spina piccola
TAP-OFF NO FUSE
UP TO 6 LIVE CONNECTORS
(STANDARD NL) 10A / 16A / 20A
*Spina senza fusibile
fino a 6 conduttori effettivi
(standard NL) 10A / 16A / 20A*

SFIP
MEDIUM TAP-OFF
Spina media
TAP-OFF FUSED/NO FUSE
UP TO 4 LIVE CONNECTORS
(STANDARD NL) 6,3A
*Spina con/senza fusibile
fino a 4 conduttori effettivi
(standard NL) 6,3A*

SBM
BIG TAP-OFF
Spina grande
TAP-OFF FUSED/NO FUSE
UP TO 6 LIVE CONNECTORS
(STANDARD NL) 6,3A / 16A / 32A
*Spina con/senza fusibile
fino a 6 conduttori effettivi
(standard NL) 6,3A / 16A / 32A*

INSTALLATION

CEILING SOFFITTO

BUSBAR CAN BE SUSPENDED AT THE CEILING BY DIRECT BRACKET OR THROUGH CHAIN ROD
 Le barre possono essere appese al soffitto sia tramite staffe dirette che tramite catanelle multifunzione



M = MINIMUM DISTANCE FROM CEILING OF THE LOWER BUSBAR PART

Distanza minima fra il soffitto e la parte inferiore della barra

- 4 CONDUCTORS 70 mm: BA25A305S - BA40A305S - BA63A305S
- 6 CONDUCTORS 140 mm: BA25A3065S - BA40A3065S - BA63A3065S

UNDERFLOOR SOTTOPAVIMENTO

BUSBAR CAN BE INSTALLED UNDER THE FLOOR IN ANY POSITION: VERTICAL OR HORIZONTAL
 La barra può essere installata sotto il pavimento in qualsiasi posizione: verticale o orizzontale

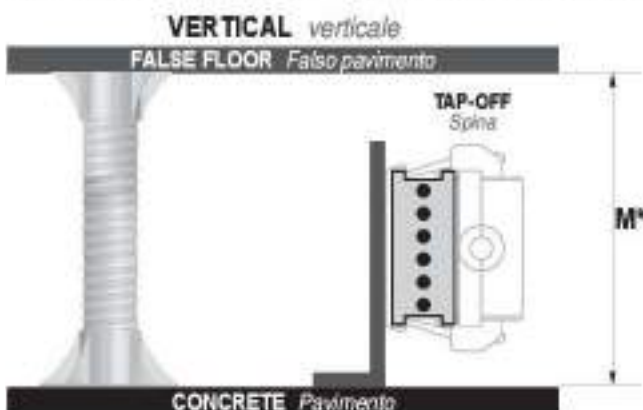

M = MINIMUM DISTANCE ADMITTED BETWEEN CONCRETE FLOOR AND FALSE FLOOR

Distanza minima ammessa fra pavimento e falso piano

- **M***: 90 mm IF THE BUSBAR IS INSTALLED IN VERTICAL POSITION
Se la barra è installata verticalmente
- **M****: 48 mm IF THE BUSBAR IS INSTALLED IN HORIZONTAL POSITION
Se la barra è installata orizzontalmente

WALL PARETE

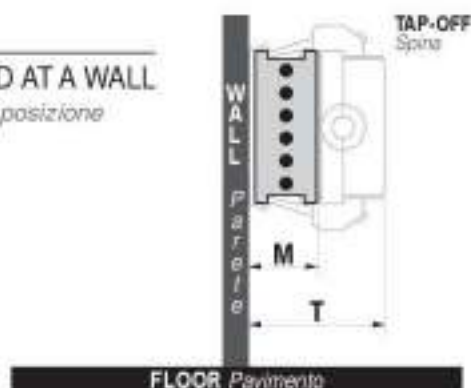

BUSBAR CAN BE INSTALLED AT A WALL
 La barra può essere installata in posizione verticale



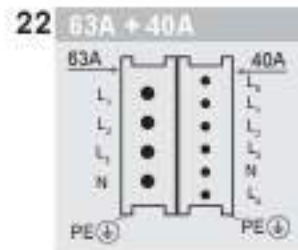
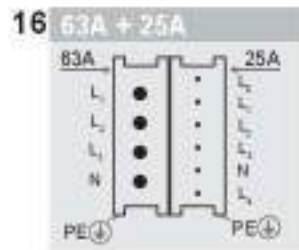
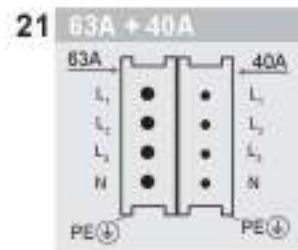
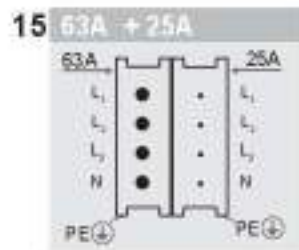
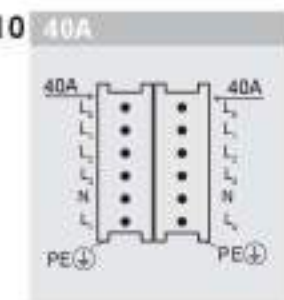
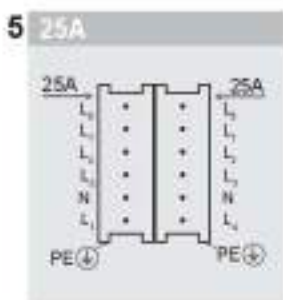
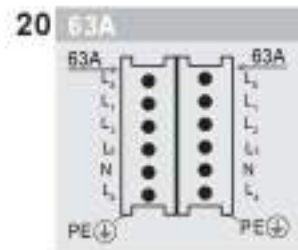
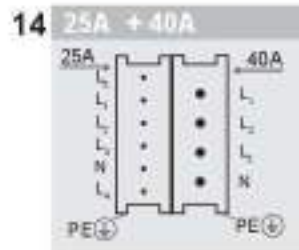
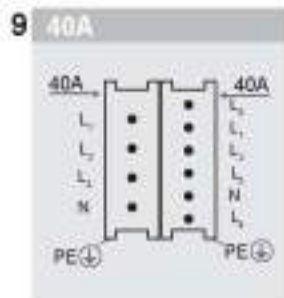
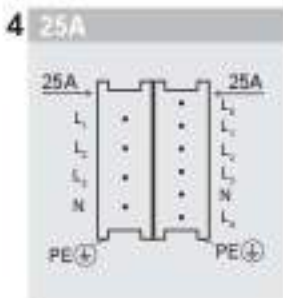
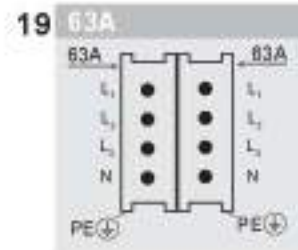
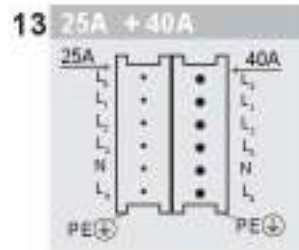
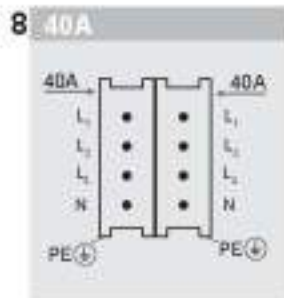
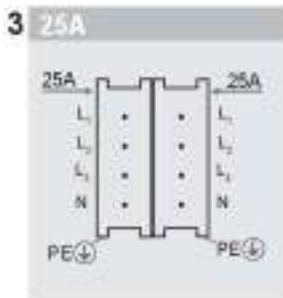
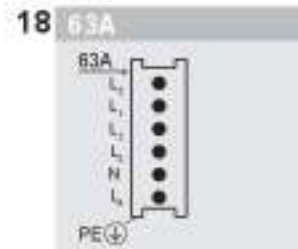
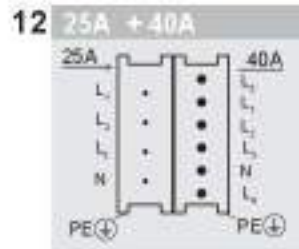
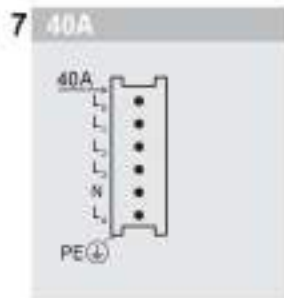
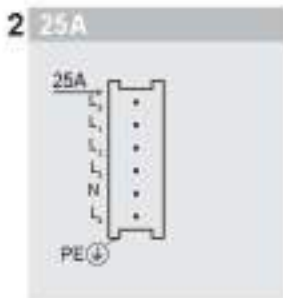
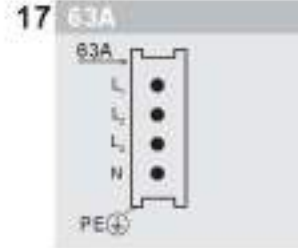
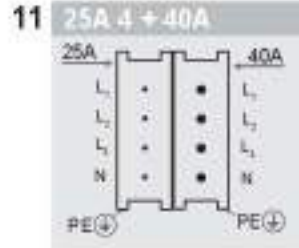
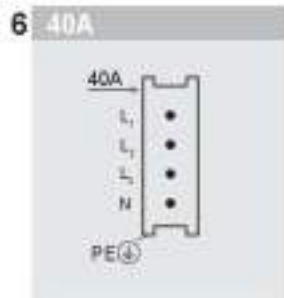
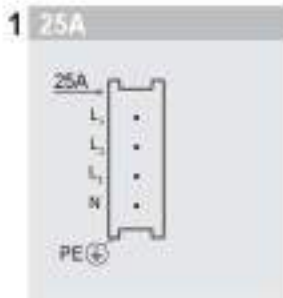

M = 5 mm MINIMUM DISTANCE BETWEEN WALL AND BUSBAR SURFACE
Distanza minima fra il muro e la superficie della barra

T = 40 mm MINIMUM DISTANCE BETWEEN WALL AND TAP-OFF LID
Distanza minima fra il muro e la linguetta di chiusura spina

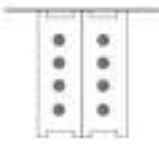
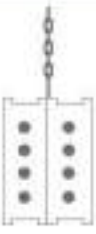

	SOFFITTO	PARETE	CATENA IN METALLO	SOFFITTO	CATENA IN METALLO
					
CEILING BRACKET WITH PLASTIC LID FOR DIRECT SUSPENSION	STCMMP				
CEILING BRACKET WITH METAL LID FOR DIRECT SUSPENSION	STCMM				
CEILING BRACKET WITH SECURITY PATH FOR DIRECT SUSPENSION	STCMMPSP				
CEILING BRACKET WITH PLASTIC LID FOR CHAIN ROD SUSPENSION	STCMSP				
CEILING BRACKET WITH METAL LID FOR CHAIN ROD SUSPENSION	STCMSP				
CEILING BRACKET WITH SECURITY PATH FOR CHAIN ROD SUSPENSION	STCMSPFP				
WALL BRACKET WITH PLASTIC LID		STCAPV			
WALL BRACKET WITH METAL LID		STCAPM			
WALL BRACKET WITH SECURITY PATH		STWBP			
SIMPLE BRACKET FOR DOUBLE CHANNEL					SEBCH
CEILING BRACKET FOR DOUBLE CHANNEL DIRECT SUSPENSION				SEBCH	
CEILING BRACKET FOR DOUBLE CHANNEL SUSPENSION WITH CHAIN ROD				SEBCH	
SPECIAL STM BRACKET WALL AND CEILING	STM	STM	STM		
LAMP BRACKET FOR SINGLE CHANNEL	STCI		STCI		
LAMP BRACKET FOR DOUBLE CHANNEL					STCDCH
SPECIAL SECURITY BRACKET FOR SECURE LAMPS CABLES STSAF	STSAF		STSAF		
SPECIAL SIMPLE CEILING BRACKET STSF FOR CHAIN SUSPENSION	STSF		STSF		STSF
DOUBLE BRACKET FOR SEPARATE DOUBLE CHANNEL STCAD				STCAD	
REINFORCE SLEEVE FOR 25A AND 40A TRUNKING	GRFP		GRFP		
REINFORCE SLEEVE FOR 63A TRUNKING	GRFPB43		GRFPB43		
REINFORCE SLEEVE FOR DOUBLE CHANNEL 25A AND 40A				RGRFPD	RGRFPD

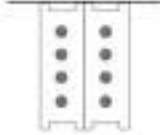
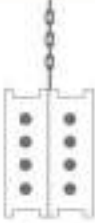
	SOFFITTO	PARETE	CATENA IN METALLO	SOFFITTO	CATENA IN METALLO
					
STAFFA PER SOFFITTO CON LINGUETTA DI PLASTICA PER SOSPENSIONE DIRETTA	STCMMP				
STAFFA PER SOFFITTO CON LINGUETTA DI METALLO PER SOSPENSIONE DIRETTA	STCMW				
STAFFA PER SOFFITTO CON PERCORSO DI SICUREZZA PER SOSPENSIONE DIRETTA	STCMMPSP				
STAFFA PER SOFFITTO CON LINGUETTA DI PLASTICA PER SOSPENSIONE CON CATENA DI METALLO	STCMSP				
STAFFA PER SOFFITTO CON LINGUETTA DI METALLO PER SOSPENSIONE CON CATENA DI METALLO	STCMWF				
STAFFA PER SOFFITTO CON PERCORSO DI SICUREZZA PER CATENA DI METALLO	STCMWFP				
STAFFA DA MURO CON LINGUETTA DI PLASTICA		STCAPV			
STAFFA DA MURO CON LINGUETTA DI METALLO		STCAPM			
STAFFA DA MURO CON PERCORSO DI SICUREZZA		STWBP			
SEMPLICE STAFFA PER DOPPIO CANALE					SBDCB
STAFFA PER SOFFITTO PER DOPPIO CANALE SOSPENSIONE DIRETTA				SBDCB	
STAFFA PER SOFFITTO PER DOPPIO CANALE SOSPENSIONE CON CATENA DI METALLO				SBDCB	
STAFFA SPECIALE STM PER PARETE E SOFFITTO	STM	STM	STM		
STAFFA PER CORPO ILLUMINANTE PER SINGOLO CANALE	STD		STCI		
STAFFA PER CORPO ILLUMINANTE PER DOPPIO CANALE					STDCB
SPECIALE STAFFA DI SICUREZZA PER CAVI CORPO ILLUMINANTE STSAF	STSAF		STSAF		
STAFFA SPECIALE SINGOLA PER SOSPENSIONE CON CATENA DI METALLO	STSF		STSF		STSF
STAFFA DOPPIA PER DOPPIO CANALE SEPARATO STCAD				STCAD	
FAZZOLETTO DI RINFORZO PER 25A E 40A	GRFP		GRFP		
FAZZOLETTO DI RINFORZO PER 25A E 40A	GRFPBA63		GRFPBA63		
FAZZOLETTO DI RINFORZO PER DOPPIO CANALE 25A E 40A				RGRFPD	RGRFPD

AT SX 25AFS FEED UNIT END CUP INCLUDED
CHIUSURA DI TESTATA INCLUSA

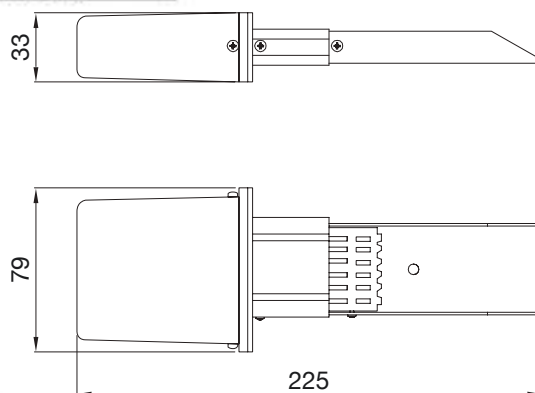

3P + N + PE
AMP 25 A
IP 41 - *IP 55
0,220
6 mm ² TERMINAL BLOCK MORSETTIERA
0,57 Dm ³ VOLUME AFTER PACKING VOLUME IMBALLATO

AT DX 25AFS FEED UNIT END CUP INCLUDED
CHIUSURA DI TESTATA INCLUSA

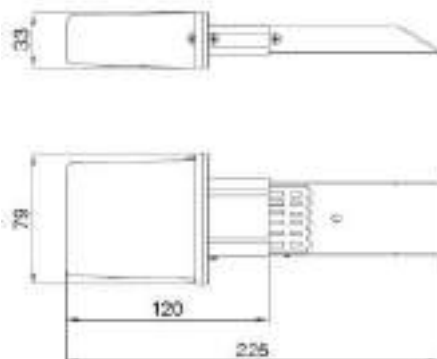

3P + N + PE
AMP 25 A
IP 41 - *IP 55
0,380
6 mm ² TERMINAL BLOCK MORSETTIERA
0,82 Dm ³ VOLUME AFTER PACKING VOLUME IMBALLATO

AT SX 25AF FEED UNIT END CUP INCLUDED
CHIUSURA DI TESTATA INCLUSA

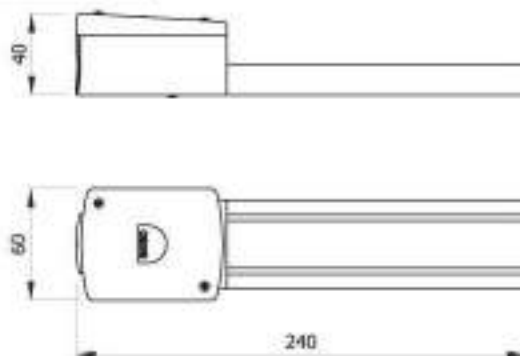

3P + N + PE
AMP 25 A
IP 41 - *IP 55
0,220
6 mm ² TERMINAL BLOCK MORSETTIERA
0,57 Dm ³ VOLUME AFTER PACKING VOLUME IMBALLATO

AT DX 25AF FEED UNIT END CUP INCLUDED
CHIUSURA DI TESTATA INCLUSA

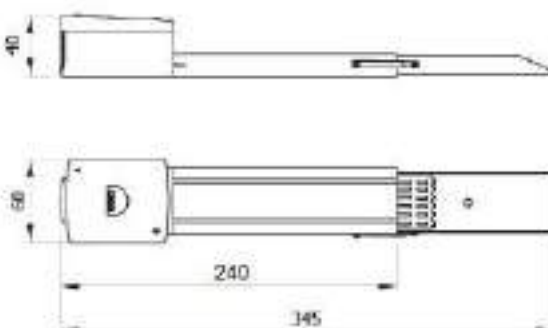

3P + N + PE
AMP 25 A
IP 41 - *IP 55
0,380
6 mm ² TERMINAL BLOCK MORSETTIERA
0,82 Dm ³ VOLUME AFTER PACKING VOLUME IMBALLATO

ATSX 25A6F FEED UNIT END CUP INCLUDED
CHIUSURA DI TESTATA INCLUSA

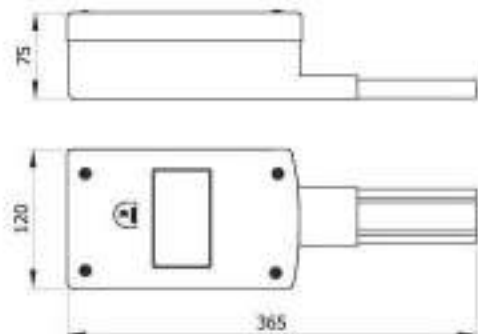

5P + N + PE
AMP 25 A
IP 41 - *IP 55
0,583
6 mm ² TERMINAL BLOCK MORSETTIERA
3,20 Dm ³ VOLUME AFTER PACKING VOLUME IMBALLATO

ATDX 25A6F FEED UNIT END CUP INCLUDED
CHIUSURA DI TESTATA INCLUSA

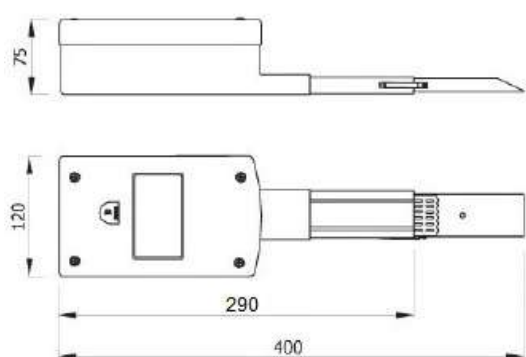

5P + N + PE
AMP 25 A
IP 41 - *IP 55
0,850
6 mm ² TERMINAL BLOCK MORSETTIERA
4,10 Dm ³ VOLUME AFTER PACKING VOLUME IMBALLATO

ATSX 40A6F FEED UNIT END CUP INCLUDED
CHIUSURA DI TESTATA INCLUSA

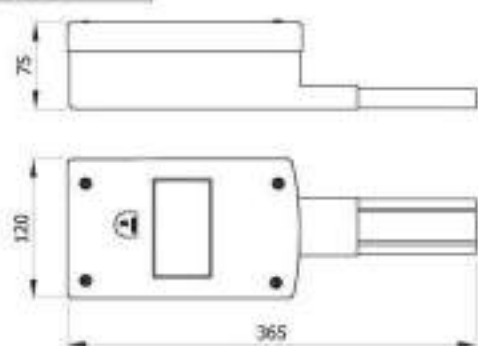

5P + N + PE
AMP 40 A
IP 41 - *IP 55
0,606
16 mm ² TERMINAL BLOCK MORSETTIERA
3,20 Dm ³ VOLUME AFTER PACKING VOLUME IMBALLATO

ATDX 40A6F FEED UNIT END CUP INCLUDED
CHIUSURA DI TESTATA INCLUSA

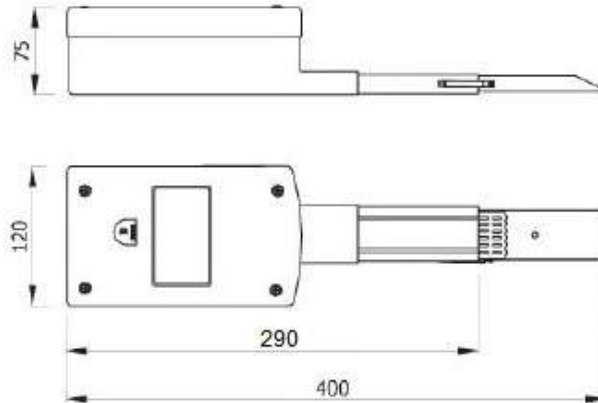

5P + N + PE
AMP 40 A
IP 41 - *IP 55
0,850
16 mm ² TERMINAL BLOCK MORSETTIERA
4,10 Dm ³ VOLUME AFTER PACKING VOLUME IMBALLATO

AT SX 63A6F FEED UNIT END CUP INCLUDED
CHIUSURA DI TESTATA INCLUSA

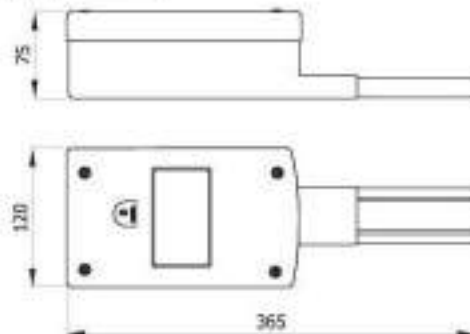

5P + N + PE
AMP 63 A
IP 41 - *IP 55
0,806
16 mm ² TERMINAL BLOCK MORSETTIERA
3,20 Dm ³ VOLUME AFTER PACKING VOLUME IMBALLATO

ATDX 63A6F FEED UNIT END CUP INCLUDED
CHIUSURA DI TESTATA INCLUSA

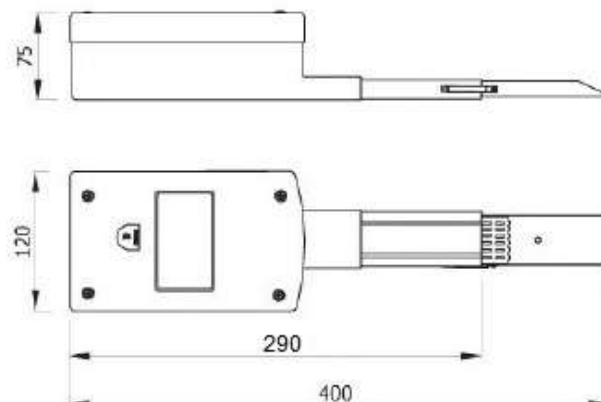

5P + N + PE
AMP 63 A
IP 41 - *IP 55
0,850
16 mm ² TERMINAL BLOCK MORSETTIERA
4,10 Dm ³ VOLUME AFTER PACKING VOLUME IMBALLATO

AC 25A CENTER FEED END CUP INCLUDED
CHIUSURA DI TESTATA INCLUSA

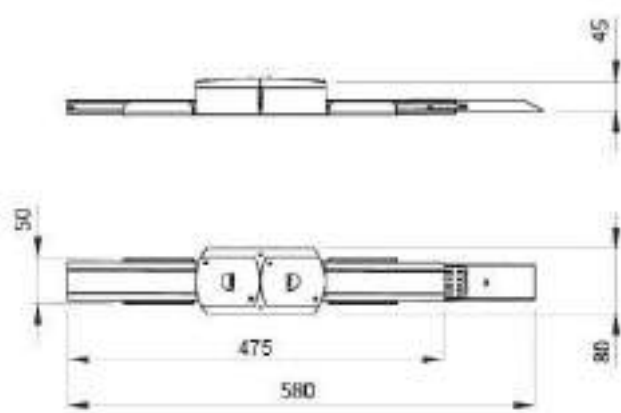

3P + N + PE
AMP 25 A
IP 41 - *IP 55
0,950
6 mm ² TERMINAL BLOCK MORSETTIERA
4,10 Dm ³ VOLUME AFTER PACKING VOLUME IMBALLATO

AC 25A6 CENTER FEED END CUP INCLUDED
CHIUSURA DI TESTATA INCLUSA

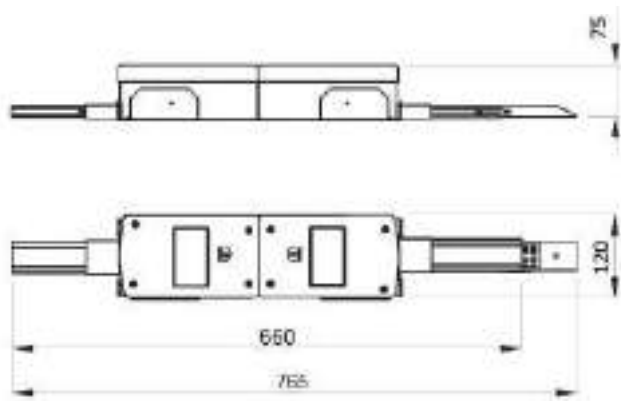

5P + N + PE
AMP 25 A
IP 41 - *IP 55
2,550
6 mm ² TERMINAL BLOCK MORSETTIERA
7,70 Dm ³ VOLUME AFTER PACKING VOLUME IMBALLATO

AC 40A6 CENTER FEED END CUP INCLUDED
CHIUSURA DI TESTATA INCLUSA

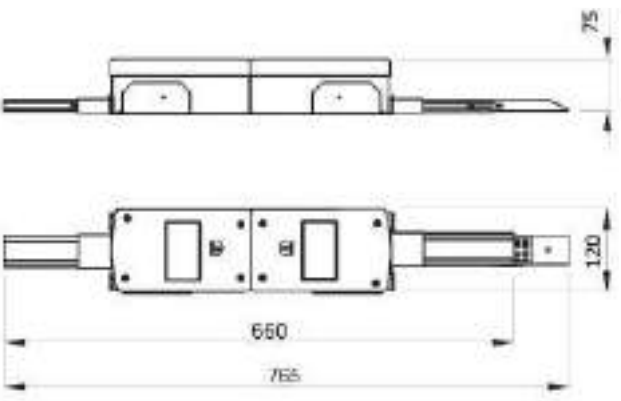

5P + N + PE
AMP 40 A
IP 41 - *IP 55
2,624
16 mm ² TERMINAL BLOCK MORSETTIERA
7,70 Dm ³ VOLUME AFTER PACKING VOLUME IMBALLATO

AC 63A6 CENTER FEED END CUP INCLUDED
CHIUSURA DI TESTATA INCLUSA

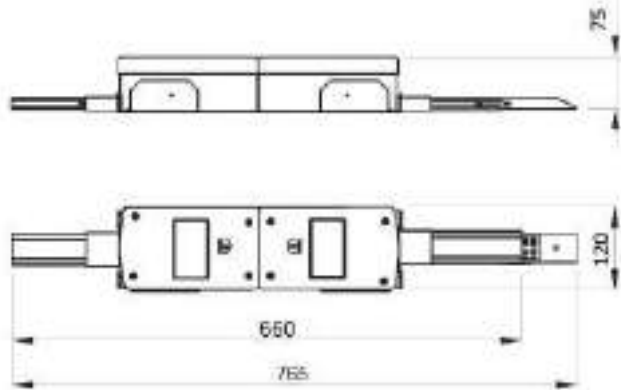

5P + N + PE
AMP 63 A
IP 41 - *IP 55
3,900
20 mm ² TERMINAL BLOCK MORSETTIERA
8,00 Dm ³ VOLUME AFTER PACKING VOLUME IMBALLATO

GFX 25A FLEXIBLE ELEMENT

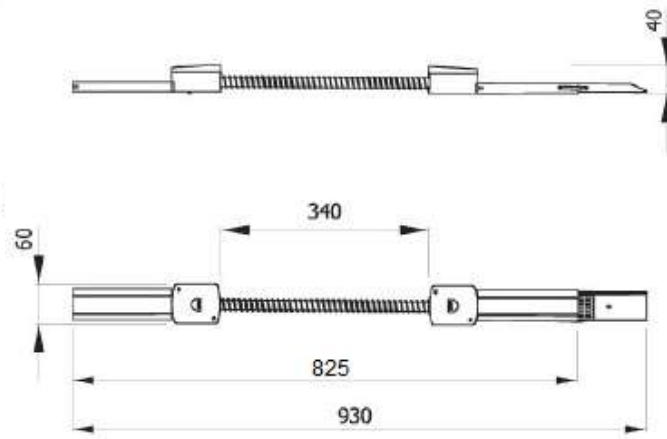

3P + N + PE
AMP 25 A
IP 41 - *IP 55
0,786
10,00 Dm ³ VOLUME AFTER PACKING VOLUME IMBALLATO

GFX 25A6 FLEXIBLE ELEMENT

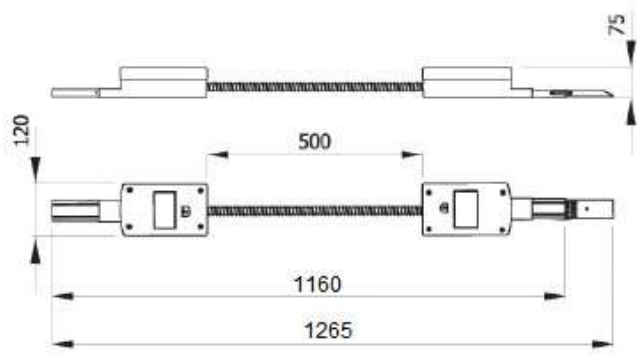

5P + N + PE
AMP 25 A
IP 41 - *IP 55
2,084
10,00 Dm ³ VOLUME AFTER PACKING VOLUME IMBALLATO

GFX 40A FLEXIBLE ELEMENT

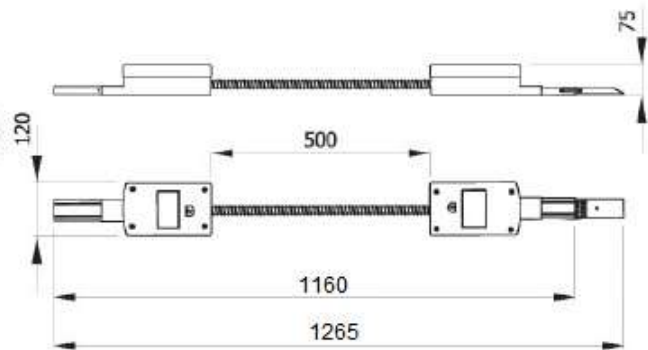

3P + N + PE
AMP 25 - 40 A
IP 41 - *IP 55
2,200
26,00 Dm ³ VOLUME AFTER PACKING VOLUME IMBALLATO

GFX 40A6 FLEXIBLE ELEMENT

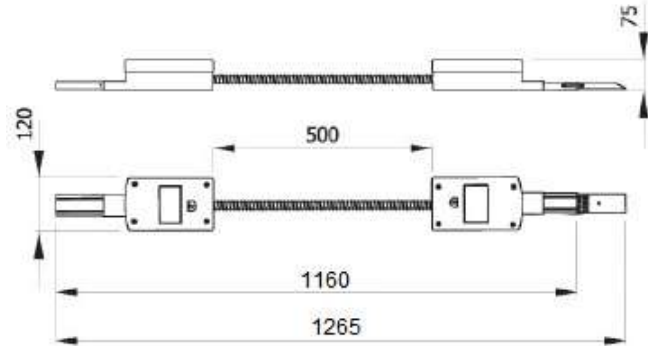

5P + N + PE
AMP 40 A
IP 41 - *IP 55
2,250
26,00 Dm ³ VOLUME AFTER PACKING VOLUME IMBALLATO

GFX 63A6 FLEXIBLE ELEMENT

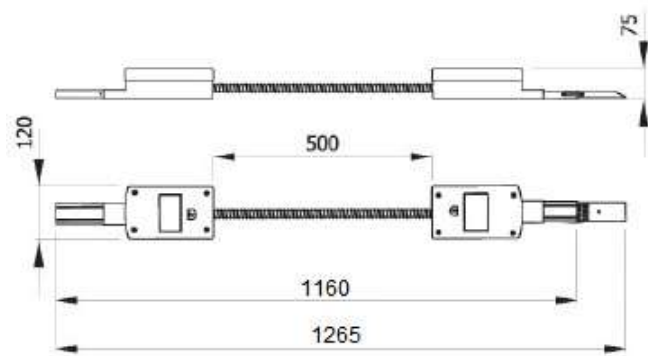

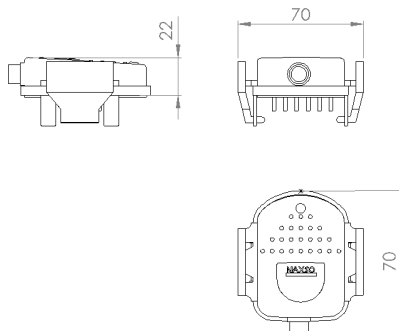
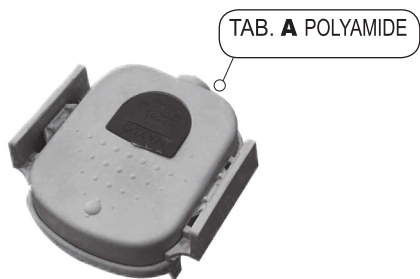

5P + N + PE
AMP 63 A
IP 41 - *IP 55
3,500
26,00 Dm ³ VOLUME AFTER PACKING VOLUME IMBALLATO

 **SM 10AN** TAP OFF





STANDARD 2 DIRECT CONTACTS 10A - 2 contatti diretti da 10A

N + L + PE
AMP 10 A
IP 41 - *IP 55
 0,084
 MAX 2,5 mm ²
 0,230 Dm ³ VOLUME AFTER PACKING VOLUME IMBALLATO

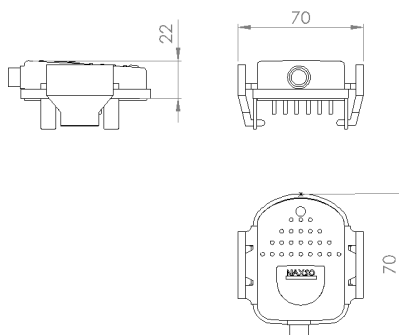
 **SM 16AN** TAP OFF





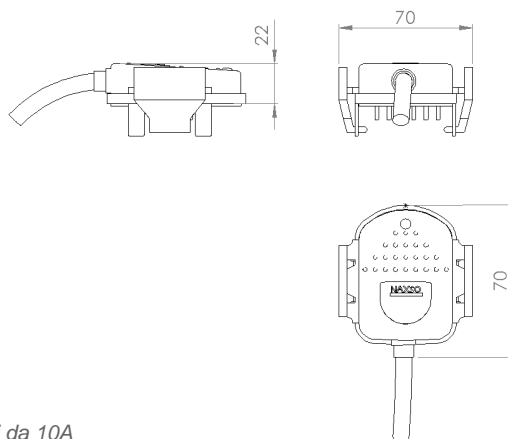
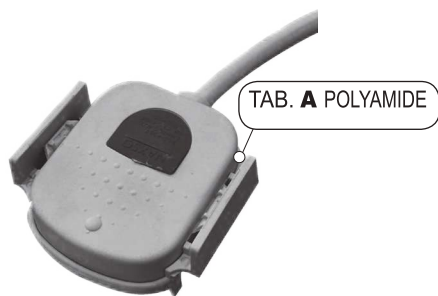

STANDARD 2 DIRECT CONTACTS 16A - 2 contatti diretti da 16A

N + L + PE
AMP 16 A
IP 41 - *IP 55
 0,086
 MAX 2,5 mm ²
 0,230 Dm ³ VOLUME AFTER PACKING VOLUME IMBALLATO

 **SM 10ACRN** TAP OFF





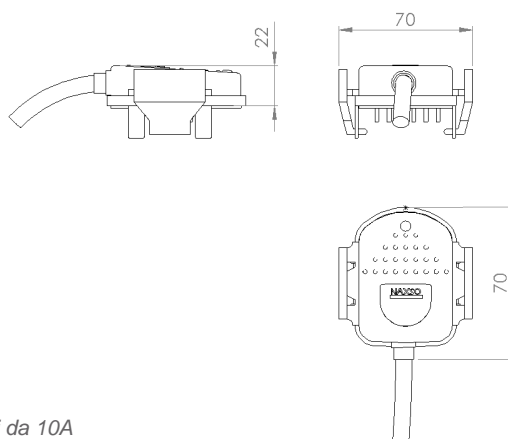
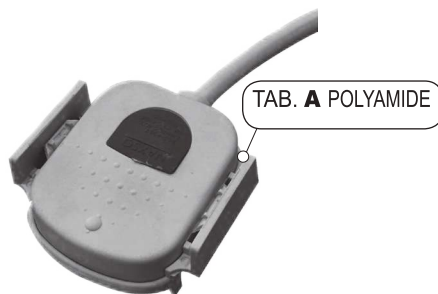

STANDARD 2 DIRECT CONTACTS 10A - 2 contatti diretti da 10A

N + L1 + PE
AMP 10 A
IP 41 - *IP 55
 0,165
 3 x 1,5 mm ² L = 0,8 mt ²
 0,580 Dm ³ VOLUME AFTER PACKING VOLUME IMBALLATO
L1N = IFSR 

 **SM 10ACGN** TAP OFF



STANDARD 2 DIRECT CONTACTS 10A - 2 contatti diretti da 10A

N + L2 + PE
AMP 10 A
IP 41 - *IP 55
 0,165
 3 x 1,5 mm ² L = 0,8 mt ²
 0,580 Dm ³ VOLUME AFTER PACKING VOLUME IMBALLATO
L2N = IFSG 

SM 10ACBN TAP OFF

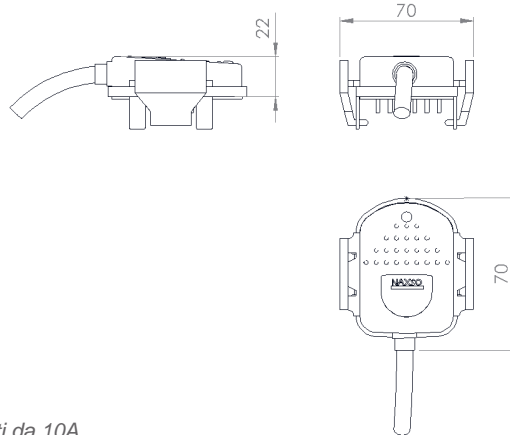
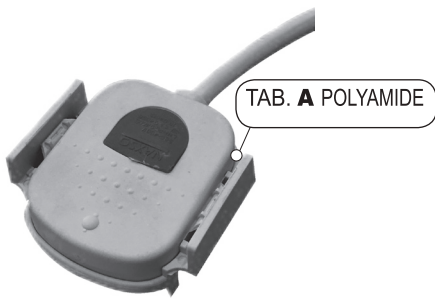

STANDARD 2 DIRECT CONTACTS 10A - 2 contatti diretti da 10A

N + L3 + PE
AMP 10 A
IP 41 - *IP 55
0,165
3 x 1,5 mm ² L = 0,8 mt ²
0,580 Dm ³ VOLUME AFTER PACKING VOLUME IMBALLATO
L3N = IFSB

SM 10ACVN TAP OFF

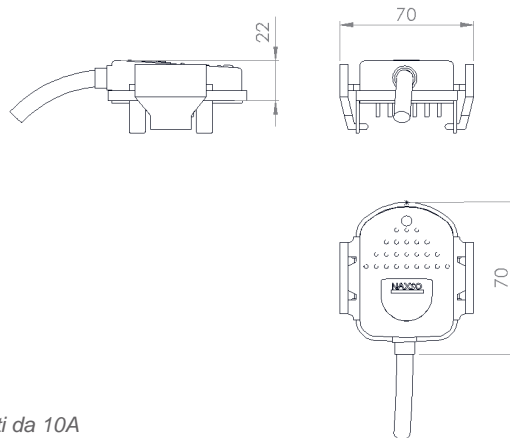
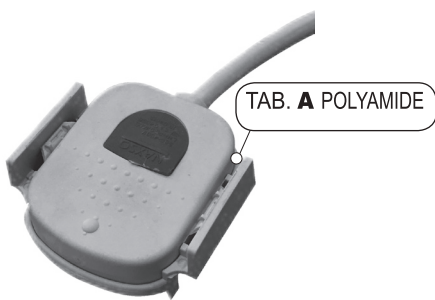

STANDARD 2 DIRECT CONTACTS 10A - 2 contatti diretti da 10A

L5 + L6 + PE
AMP 10 A
IP 41 - *IP 55
0,165
3 x 1,5 mm ² L = 0,8 mt ²
0,580 Dm ³ VOLUME AFTER PACKING VOLUME IMBALLATO
L4 L5 = IFSV

SM 20ACRN TAP OFF

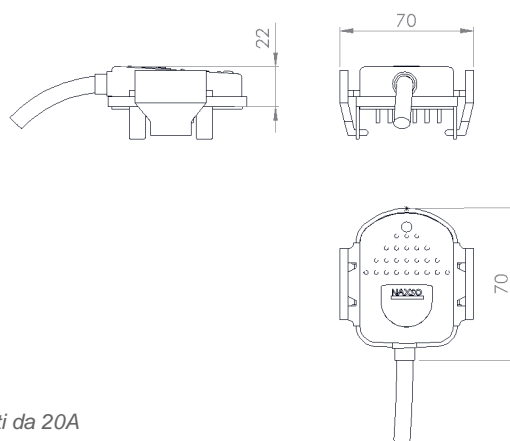
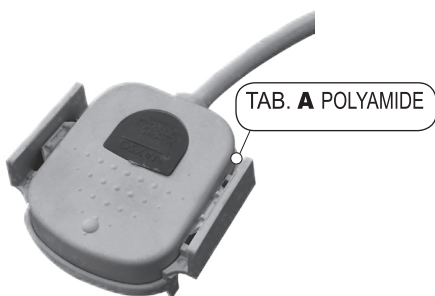

STANDARD 2 DIRECT CONTACTS 20A - 2 contatti diretti da 20A

N + L1 + PE
AMP 20 A
IP 41 - *IP 55
0,170
3 x 1,5 mm ² L = 0,8 mt ²
0,580 Dm ³ VOLUME AFTER PACKING VOLUME IMBALLATO
N L1 = IFSR

SM 20ACBN TAP OFF

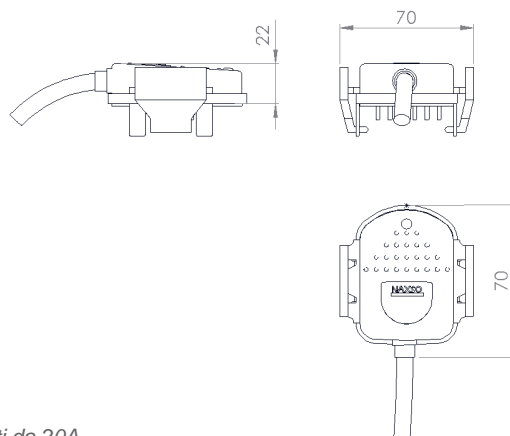
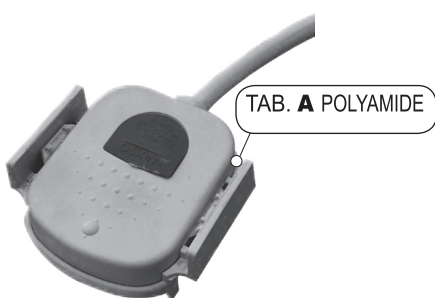

STANDARD 2 DIRECT CONTACTS 20A - 2 contatti diretti da 20A

N + L3 + PE
AMP 20 A
IP 41 - *IP 55
0,170
3 x 2,5 mm ² L = 0,8 mt ²
0,6 Dm ³ VOLUME AFTER PACKING VOLUME IMBALLATO
L3N = IFSB

SM 20ACGN TAP OFF

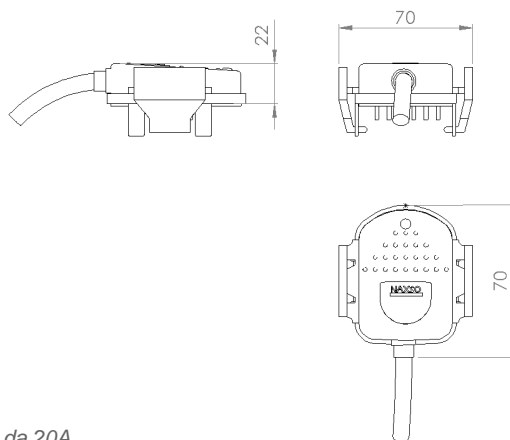

N + L2 + PE
AMP 20 A
IP 41 - *IP 55
0,170
3 x 2,5 mm² L = 0,8 mt²
0,6 Dm³ VOLUME AFTER PACKING VOLUME IMBALLATO
L2N = IFSG

STANDARD 2 DIRECT CONTACTS 20A - 2 contatti diretti da 20A

SFIP 55CRN TAP OFF

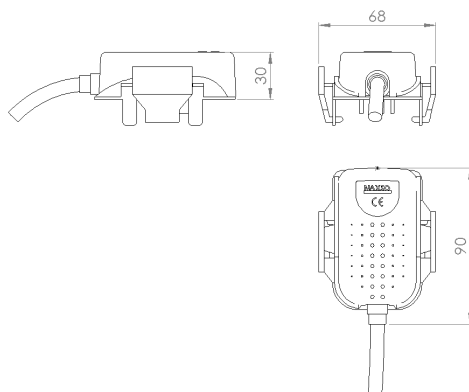

N+L1+PE
AMP 6,3 A
IP 41 - *IP 55
0,163
2,5 mm² Max 4mm² TERMINAL BLOCK MORSETTIERA
0,75 Dm³ VOLUME AFTER PACKING VOLUME IMBALLATO
3 x 1,5 mm² L = 0,8 mt²
5 x 20 - 6,3A
L1N = IFSR

STANDARD 1 FUSE CONTACT+1 DIRECT CONTACT - 1 contatto fusibile+ 1 contatto diretto

SFIP 55CGN TAP OFF

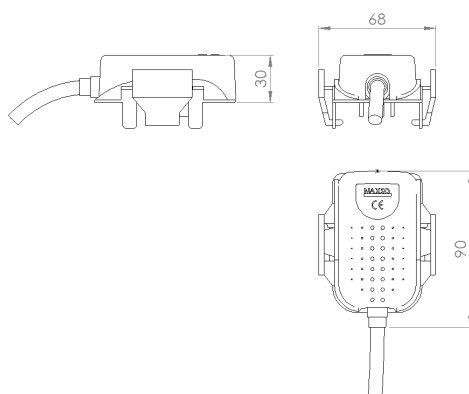

N+L2+PE
AMP 6,3 A
IP 41 - *IP 55
0,163
2,5 mm² Max 4mm² TERMINAL BLOCK MORSETTIERA
0,75 Dm³ VOLUME AFTER PACKING VOLUME IMBALLATO
3 x 1,5 mm² L = 0,8 mt²
5 x 20 - 6,3A
L2N = IFSG

STANDARD 1 FUSE CONTACT+1 DIRECT CONTACT - 1 contatto fusibile+ 1 contatto diretto

SFIP 55CBN TAP OFF

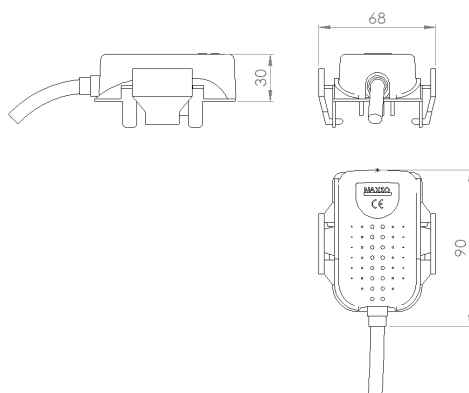

N+L3+PE
AMP 6,3 A
IP 41 - *IP 55
0,163
2,5 mm² Max 4mm² TERMINAL BLOCK MORSETTIERA
0,75 Dm³ VOLUME AFTER PACKING VOLUME IMBALLATO
3 x 1,5 mm² L = 0,8 mt²
5 x 20 - 6,3A
L3N = IFSB

STANDARD 1 FUSE CONTACT+1 DIRECT CONTACT - 1 contatto fusibile+ 1 contatto diretto

SFIPN TAP OFF

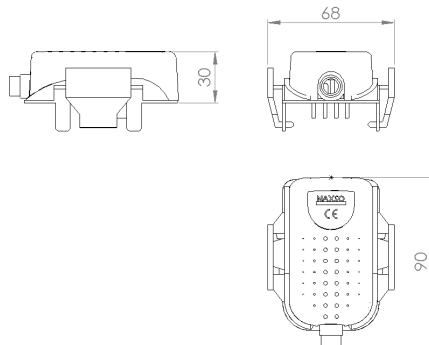

STANDARD 1 FUSE CONTACT+1 DIRECT CONTACT - 1 contatto fusibile+ 1 contatto diretto

1P + N + PE
AMP 6,3 A
IP 41 - *IP 55
0,068
2,5 mm² Max 4mm² TERMINAL BLOCK MORSETTIERA
0,75 Dm³ VOLUME AFTER PACKING VOLUME IMBALLATO
5 x 20 - 6,3A

SBM 6A TAP OFF

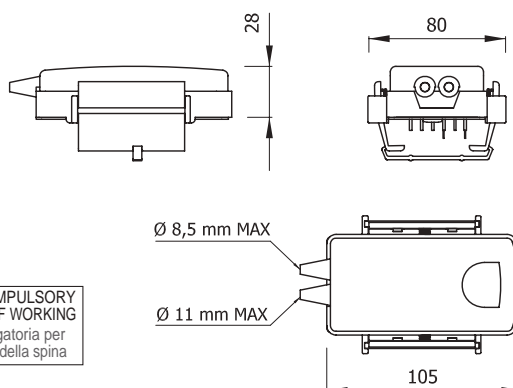

STANDARD 1 FUSE CONTACT+1 DIRECT CONTACT - 1 contatto fusibile+ 1 contatto diretto

N+L+PE
AMP 6,3 A
IP 41 - *IP 55
0,130
2,5 mm² Max 6mm² TERMINAL BLOCK MORSETTIERA
0,75 Dm³ VOLUME AFTER PACKING VOLUME IMBALLATO
5 x 20 - 6,3A

SBM 16A TAP OFF

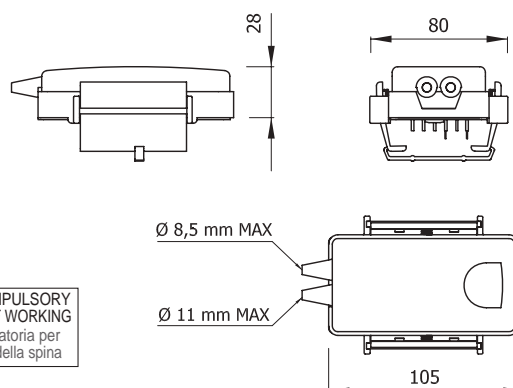

STANDARD 1 FUSE CONTACT+1 DIRECT CONTACT - 1 contatto fusibile+ 1 contatto diretto

N+L+PE
AMP 16 A
IP 41 - *IP 55
0,130
2,5 mm² Max 6mm² TERMINAL BLOCK MORSETTIERA
0,75 Dm³ VOLUME AFTER PACKING VOLUME IMBALLATO
5 x 20 - 16A

SBM 20A TAP OFF

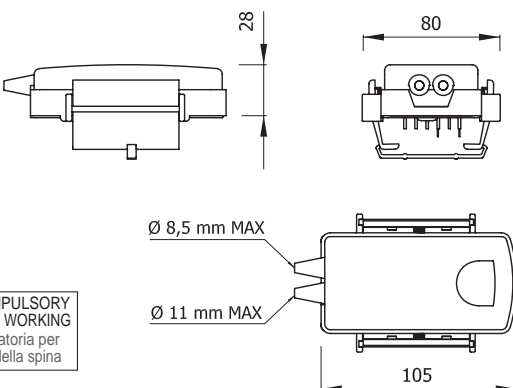

STANDARD 1 FUSE CONTACT+1 DIRECT CONTACT - 1 contatto fusibile+ 1 contatto diretto

1P + N + PE
AMP 20 A
IP 41 - *IP 55
0,130
2,5 mm² Max 6mm² TERMINAL BLOCK MORSETTIERA
CMSF20 + 1 CMCF20 + 1
0,75 Dm³ VOLUME AFTER PACKING VOLUME IMBALLATO
5 x 20 - 20A

SBM 32A TAP OFF

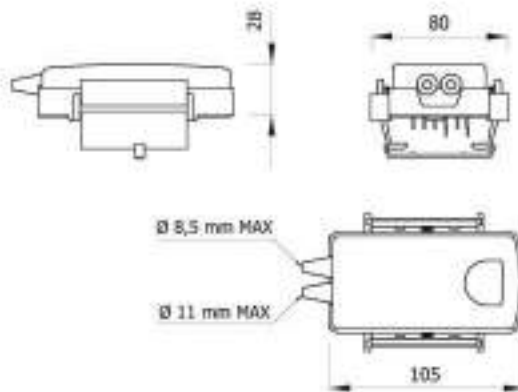

1P + N + PE
AMP 32 A
IP 41 - *IP 55
0,130
2,5 mm² Max 6mm² TERMINAL BLOCK <small>ACRISSETTERA</small>
CMSF 32 x 2
0,75 Dm³ VOLUME AFTER PACKING <small>VOLUME IMBALLATO</small>
3 x 6 mm² L = 3 mt²

STANDARD 2 DIRECT CONTACTS 32 A
2 contatti diretti da 32 A

MOUSE TAP OFF



BIG MOUSE TAP OFF

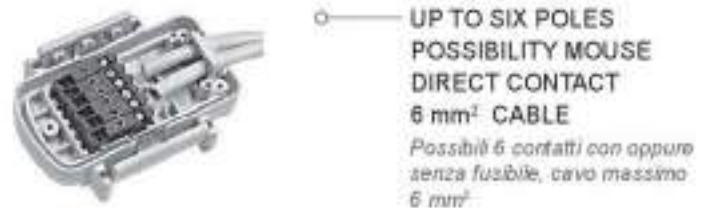

GRIP 55 IP 55 PART



GRFP REINFORCEMENT SLEEVE
Staffa di rinforzo

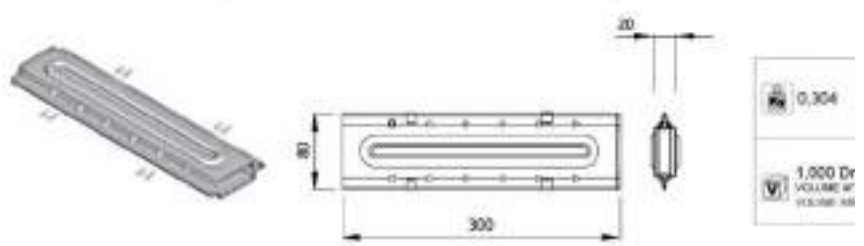

CTIP 55 IP 55 END CUP FOR ATSX
CHIUSURA DI TESTATA PER ALIMENTATORI ATSX

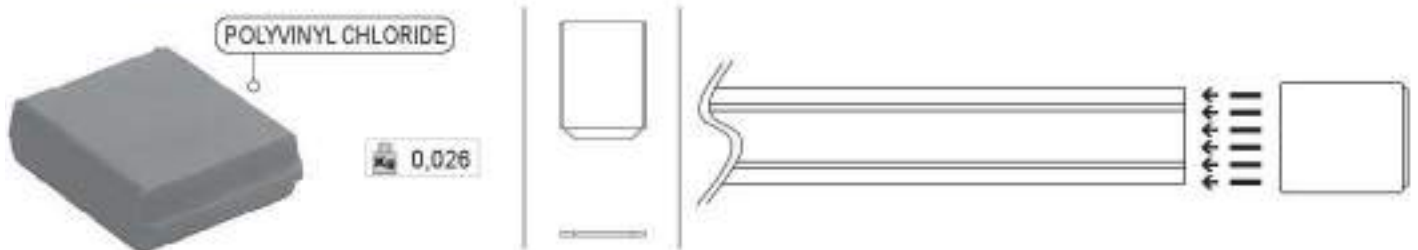

CTIP 55DX IP 55 END CUP FOR ATSX
CHIUSURA DI TESTATA PER ALIMENTATORI ATSX

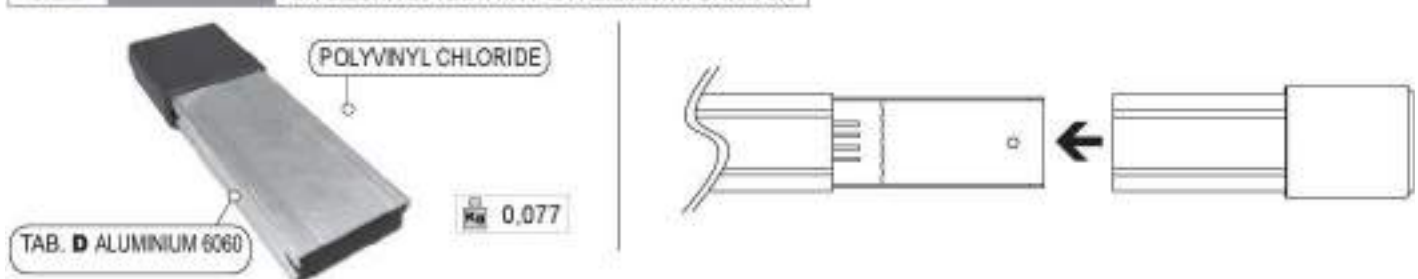

L1N = IFSR



RED
ROSSO

TAB. A POLYAMIDE
pag 101

L3N = IFSB



BLUE
BLU

COLORED PINS TO IDENTIFY CIRCUITS
SCUDETTI IDENTIFICATIVI



YELLOW
GIALLO

L2N = IFSG



TAB. A POLYAMIDE
pag 101

L4 L5 = IFSV



GREEN
VERDE

SPARE CONTACT FOR MOUSE TAP OFF
CONTATTO SCIOLTO PER SPINA MOUSE

CMSFM



IP
AMP 16A
MAX 2,5 mm ²

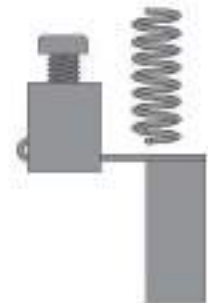

SPARE DIRECT OR FUSED CONTACT FOR SFIP AND SBM TAP OFF
CONTATTI DIRETTI O CON FUSIBILE PER SPINE TIPO SFIP E SBM

CMCF16



TAB. A POLYAMIDE
pag 101

16A FUSE 5 x 20
6 mm² cable
16A con fusibile 5 x 20
cavo 6mm²

CMSF16



TAB. A POLYAMIDE
pag 101

DIRECT CONTACT 16A
6 mm² cable
Contatto diretto 16A
cavo 6mm²

CMCF20



TAB. A POLYAMIDE
pag 101

20A FUSE 5 x 20
6mm² cable
20A con fusibile 5 x 20
cavo 6 mm²

CMCF



TAB. A POLYAMIDE
pag 101

6,3A FUSE 5 x 20
6mm² cable
6,3A con fusibile 5 x 20
cavo 6mm²

CMSF



TAB. A POLYAMIDE
pag 101

DIRECT CONTACT 6,3A
6 mm² cable
Contatto diretto 6,3A
cavo 6mm²

CMSF20



TAB. A POLYAMIDE
pag 101

DIRECT CONTACT 20A
6 mm² cable
Contatto diretto 20A
cavo 6mm²

STAFFE NAXSOLUX

STCMMP

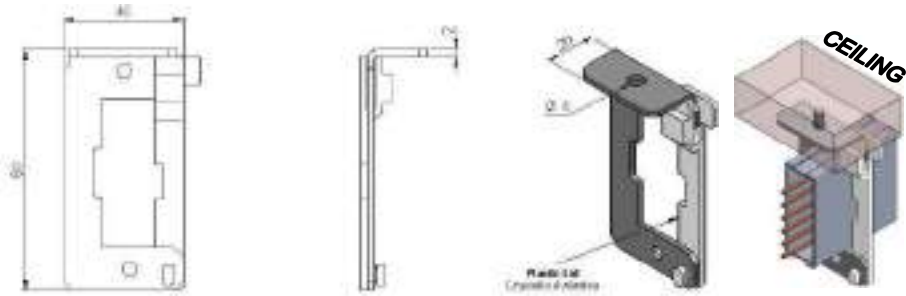

EASY CEILING BRACKETS
 PLASTIC STRONG LID
 TO BE INSTALLED DIRECTLY ON CEILING
 OR THROUGH A THREADED ROD

STCMM

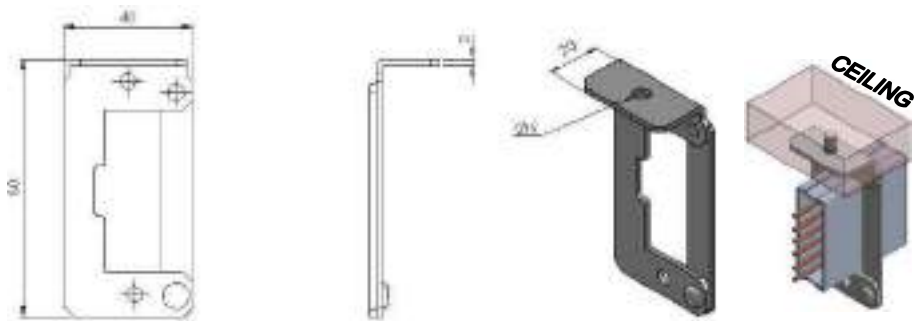

EASY CEILING BRACKETS
 METAL LID
 TO BE INSTALLED DIRECTLY ON CEILING
 OR THROUGH A THREADED ROD

STCAPV

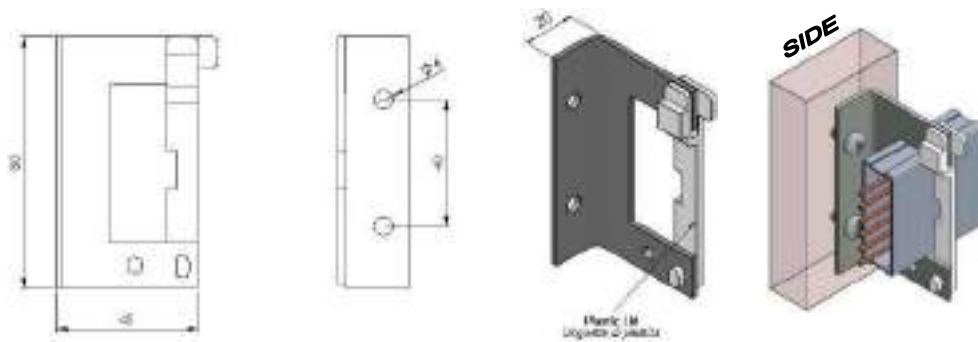

WALL BRACKET
 WITH STRONG PLASTIC LID

STCAP

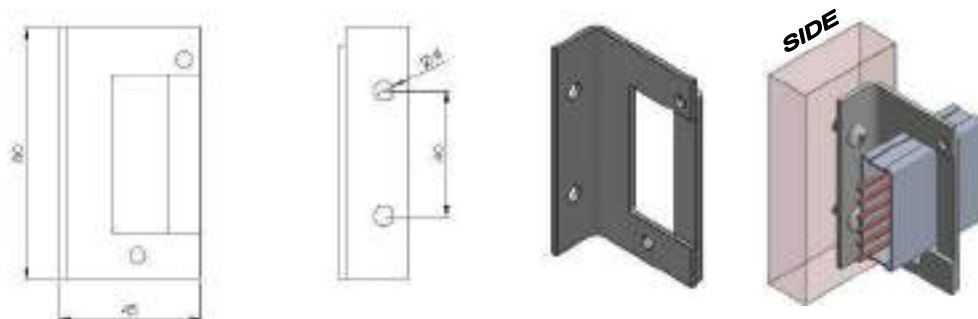

WALL BRACKET
 WITH METAL LID

STCAPS

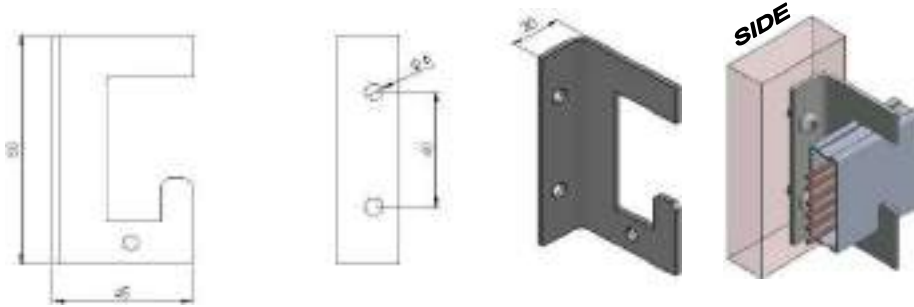

SAFETY EASY WALL BRACKET THE BUSBAR IS SLOTTED INTO THE SPACE AND THAN THE WEINGHT MAKES THE BUSBAR STAY DOWN IN POSITION

STCAS



SAFETY EASY CEILING BRACKET THE BUSBAR IS SLOTTED INTO THE SPACE AND THAN THE WEINGHT MAKES THE BUSBAR STAY DOWN IN POSITION

STCMSP

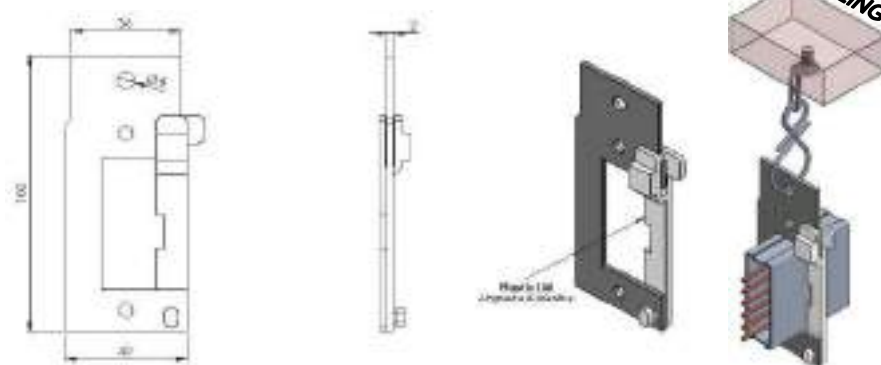

STRAIGHT CHAIN BRACKET TO BE HANGED WITH A CHAIN AND A ST8 HOOK
PLASTIC LID

STCMSF



STRAIGHT CHAIN BRACKET TO BE HANGED WITH A CHAIN AND A ST8 HOOK
METAL LID

STCADP

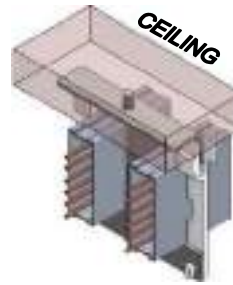
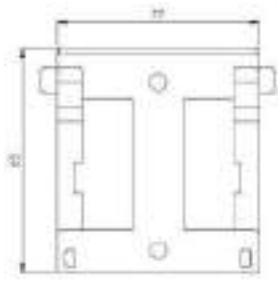

CEILING BRACKET TO LET TWO BUSBARS BACK TO BACK
INSTALLATION PLASTIC LIDS

STCAD

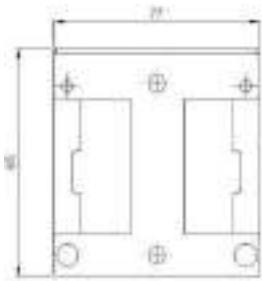

CEILING BRACKET TO LET TWO BUSBARS BACK TO BACK
INSTALLATION METAL LIDS

STCMCP

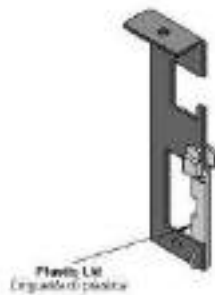
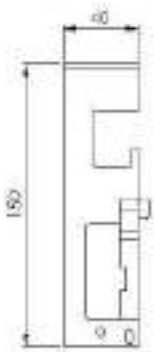

SPECIAL CEILING BRACKET TO LET A BUSBAR PLUS AN ADDITIONAL CABLE TRAY PLASTIC OR A PIPE TO BE INSTALLED
PLASTIC LID
ROOM FOR PIPE 20X20 MM

STCMC

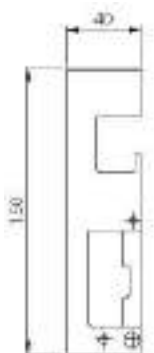

SPECIAL CEILING BRACKET TO LET A BUSBAR PLUS AN ADDITIONAL CABLE TRAY PLASTIC OR A PIPE TO BE INSTALLED
METAL LID
ROOM FOR PIPE 20X20 MM

STM

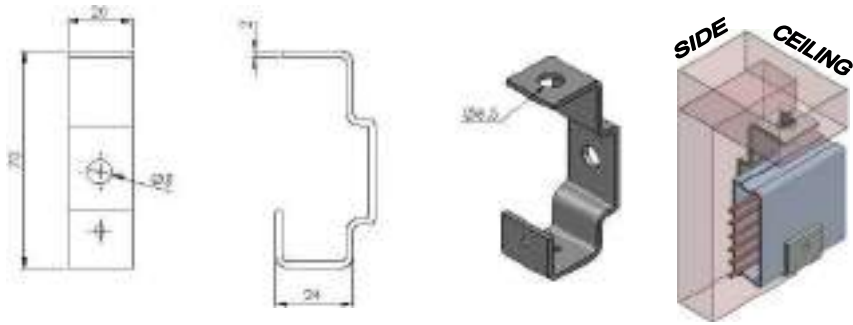

MULTI PURPOSE BRACKET TO LET A CEILING ON A WALL INSTALLATION REVERSE WAY CAN EVEN HOLD A LAMP

STCI



SPRING BRACKET TO BE HANGED TO A CHAIN OR TO HANG A LAMP

STSAF

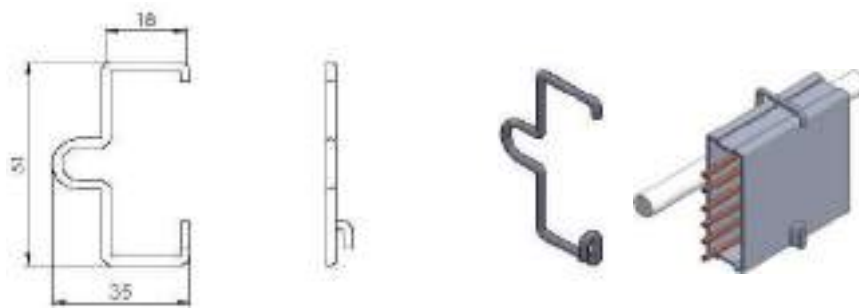

SAFETY BRACKET TO FIX STRONGLY THE CABLE OF THE TAP OFF TO THE BUSBAR

ST8



HOOK SPRING MADE TO HOLD A CHAING



Nome / Name / Caratteristica		EN 61439-6															
		25 A 2 POU	25 A 4 POU	25 A 6 POU	40 A 2 POU	40 A 4 POU	40 A 6 POU	63 A 6 POU	63 A 6 POU	25 A 2+2 POU	25 A 4+2 POU	25 A 4+4 POU	25 A 6+4 POU	40 A 2+2 POU	40 A 4+2 POU	40 A 4+4 POU	40 A 6+6 POU
Conduttori attivi Live conductors	N	2	4	6	2	4	6	4	6	2+2	4+2	4+4	6+4	2+2	4+2	4+4	6+6
Parti di derivazione (n. 2 int.) Winding standard (n. 2 int.)	n	5								5+5							
Ingombro del conduttore Overall dimensions of the busbar	mm	17x47								36x47							
Spessore dell'involucro Insulating thickness	mm	0,8															
Corrente nominale Rated current	mA	25	25	25	40	40	40	63	63	25	25	25	25	40	40	40	40
Sezione dei conduttori in Cu L ₁ , L ₂	mm ²	2,5	2,5	2,5	6	6	6	6,7	6,7	2,5	2,5	2,5	2,5	6	6	6	6
Sezione involucro di protezione (Aluminio) Protective housing (Aluminium)	mm ²	100	100	100	100	100	100	100	100	200	200	200	200	200	200	200	200
Frequenza Frequency	f [Hz]	50/60															
Tensione nominale Rated operational voltage	U [V]	400															
Tensione di isolamento Rated insulation voltage	U [V]	600															
Grado di protezione Protection degree	IP	55															
Corrente ammissibile di breve durata (0,1 sec.) Rated short-circuit current (0,1 sec.)	I _{sc} [kA]	2,4	2,4	2,4	3,0	3,0	3,0	4,0	4,0	2,4	2,4	2,4	2,4	3,0	3,0	3,0	3,0
Corrente di picco Peak current	I _p [kA]	4,5	4,5	4,5	5,3	5,3	5,3	7,0	7,0	4,5	4,5	4,5	4,5	5,3	5,3	5,3	5,3
Limite termico Maximum thermal limit	kU ² [A ² h/°C]	0,784	0,784	0,784	0,9	0,9	0,9	1,6	1,6	0,784	0,784	0,784	0,784	0,9	0,9	0,9	0,9
Resistenza di fase @ 30° C Phase resistance @ 30° C	R _e [mΩ/m]	6,7	6,7	6,7	3,2	3,2	3,2	1,4	1,4	6,7	6,7	6,7	6,7	3,2	3,2	3,2	3,2
Resistenza @ 50 Hz Resistance @ 50 Hz	X [mΩ/m]	0,23	0,23	0,23	0,24	0,24	0,24	0,24	0,24	0,23	0,23	0,23	0,24	0,24	0,24	0,24	0,24
Impedenza di fase Phase impedance	Z [mΩ/m]	6,7	6,7	6,7	3,2	3,2	3,2	1,4	1,4	6,7	6,7	6,7	6,7	3,2	3,2	3,2	3,2
Resistenza del conduttore di protezione Resistance of protective bar	R _{pe} [mΩ/m]	0,32	0,32	0,32	0,32	0,32	0,32	0,32	0,32	0,16	0,16	0,16	0,16	0,16	0,16	0,16	0,16
Resistenza @ 50 Hz conduttore di protezione Resistance @ 50 Hz protective bar	X _{pe} [mΩ/m]	0,22	0,22	0,22	0,22	0,22	0,22	0,22	0,22	0,28	0,28	0,28	0,28	0,28	0,28	0,28	0,28
Resistenza anello di giunto Resistance of busbar loop	R _g [mΩ/m]	7,4	7,4	7,4	3,5	3,5	3,5	1,7	1,7	7,4	6,9	6,9	6,9	3,3	3,3	3,3	3,3
Resistenza @ 50 Hz anello di giunto Resistance @ 50 Hz busbar loop	X _g [mΩ/m]	0,45	0,45	0,45	0,45	0,45	0,45	0,45	0,45	0,39	0,38	0,39	0,39	0,39	0,39	0,39	0,39
Impedenza anello di giunto Busbar loop impedance	Z _g [mΩ/m]	7,1	7,1	7,1	3,4	3,5	3,5	1,6	1,6	7,1	6,9	6,9	6,9	3,4	3,4	3,4	3,4
Perdite joule Joule losses L ₁ , L ₂	W/m	8,4	12,6	21,0	18,1	15,2	25,4	16,7	16,7	16,8	21,0	25,2	42,0	20,3	25,4	30,4	33,3
Cadute di tensione per carico distribuito Voltage drop with distributed load [mV/A] W=5	0,4	5,51	4,77	4,77	2,32	2,32	2,32	1,09	1,09	4,77	4,77	4,77	4,78	2,32	2,32	2,32	2,32
	0,4	6,15	5,32	5,32	2,56	2,56	2,56	1,18	1,18	5,32	5,32	5,32	5,33	2,56	2,56	2,56	2,56
	1	6,72	5,82	5,82	2,75	2,75	2,75	1,21	1,21	5,82	5,82	5,82	5,82	2,75	2,75	2,75	2,75
Temperatura ambiente Ambient temperature reference	T [°C]	5°C / +50°C															

THE LAST MODERN ELECTRONIC PARTS IN AN ELECTRICAL NETWORK LIKE THYRISTORS COMPUTERS AND ALL THE ELECTRONIC MACHINE CONTROLS HAVE CAUSED THE ARISE OF A NEW PHENOMENA THAT IS HARMONICS AND DIRTY CURRENT

SO PLEASE CHECK CAREFULLY THE FOLLOWING ITEMS BEFORE ORDERING MATERIALS :

- A- CHECK EXTRA OVERLOADS CAUSED BY LAMPS OR INDUCTIVE PARTS LIKE SMALL TRANSFORMERS
- B- CHECK THE CIRCUIT PROTECTION THAT IN A NORMAL PROJECT DESIGN IS NOT ASSURED BY CIRCUIT BREAKER AS THE STANDARD MCB OR MCCB HAVE THE CAPACITY TO STAND LONG TIME BEFORE BREAKING AND TRIPPING
- C- TAKE INTO ACCOUNT THAT FUSES ARE NOT USUALLY ABLE TO PROTECT AGAINST OVERLOADS
- D- GET DIMENSIONED THE CIRCUIT BREAKER SMALLER THAN THE CIRCUIT DUE TO PROTECT SMALLER IN RATING THAT THE THEORETICAL SUMM OF ALL THE LOADS
- E- PLASTIC INJECTION MACHINE AND WELDING MACHINERY ARE USUALLY THE CAUSE OF A TRIPPING OR FLASHING IF NOT CORRECTLY PROTECTED CAREFULLY CHECK ALL THE REQUIREMENTS WHERE SUCH A KIND OF MACHINERY IS CONNECTED TO THE ELECTRICAL NET



- 25A 4P EACH PHASE (N-L1) (N-L2) (N-L3) : 150w MAX 7 LAMPS
400w MAX 5 LAMPS
- 40A 4P EACH PHASE (N-L1) (N-L2) (N-L3) : 150w MAX 10 LAMPS
400w MAX 9 LAMPS



- 25A 4P EACH PHASE (N-L1) (N-L2) (N-L3) : 150w MAX 6 LAMPS
400w MAX 5 LAMPS
- 40A 4P EACH PHASE (N-L1) (N-L2) (N-L3) : 150w MAX 9 LAMPS
400w MAX 8 LAMPS



- 25A 4P EACH PHASE (N-L1) (N-L2) (N-L3) : 60w MAX 35 LAMPS LED
100w MAX 25 LAMPS LED
- 40A 4P EACH PHASE (N-L1) (N-L2) (N-L3) : 60w MAX 50 LAMPS LED
100w MAX 20 LAMPS LED



- 25A 4P EACH PHASE (N-L1) (N-L2) (N-L3) : 60w MAX 32 LAMPS LED
100w MAX 23 LAMPS LED
- 40A 4P EACH PHASE (N-L1) (N-L2) (N-L3) : 60w MAX 47 LAMPS LED
100w MAX 17 LAMPS LED

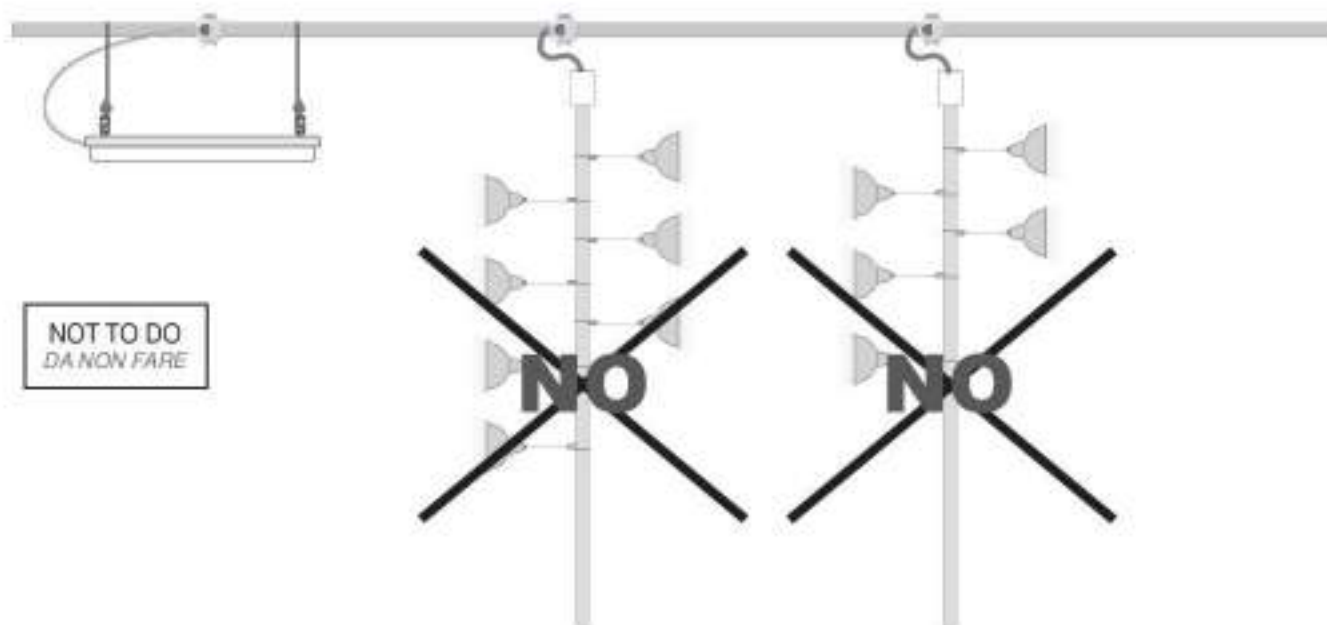

DISTANCE BETWEEN BRACKETS WHEN THE INSTALLATION IS DIRECT TO THE CEILING THE WEIGHTS ARE ACCORDING THE CHART
 DISTANZA TRA STAFFAGGI PER INSTALLAZIONE DIRETTA A SOFFITTO PER PESI DI LAMPADIE COME DA TABELLA

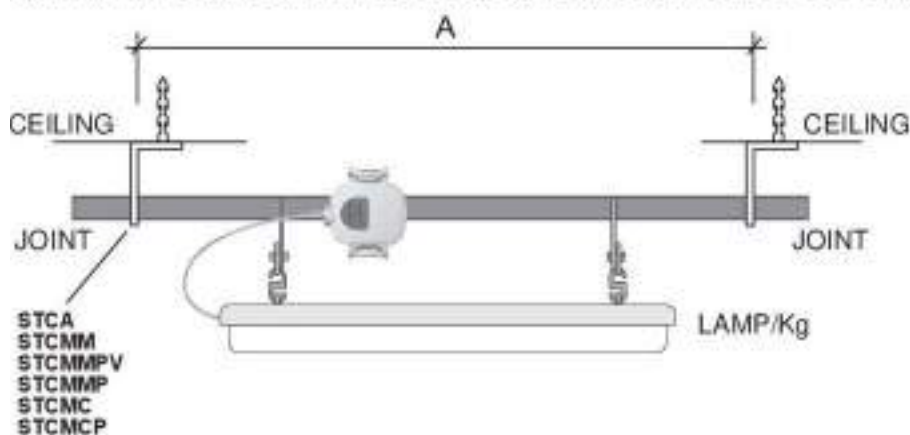

A	Kg ▶ ▲
1,5	22 Kg
2,0	15 Kg
2,5	12 Kg
3	8 Kg

BUSBAR INSTALLATION WITH CHAIN, THE LENGHT OF THE CHAIN INFLUENCE THE WEIGHT ADMITTED FOR LAMPS
 INSTALLAZIONE A SOFFITTO TRAMITE CATENELLA. LA LUNGHEZZA DELLA CATENELLA INFLUENZA LA PORTATA IN KG DELLA BARRA

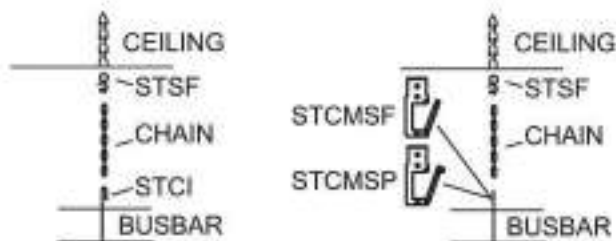
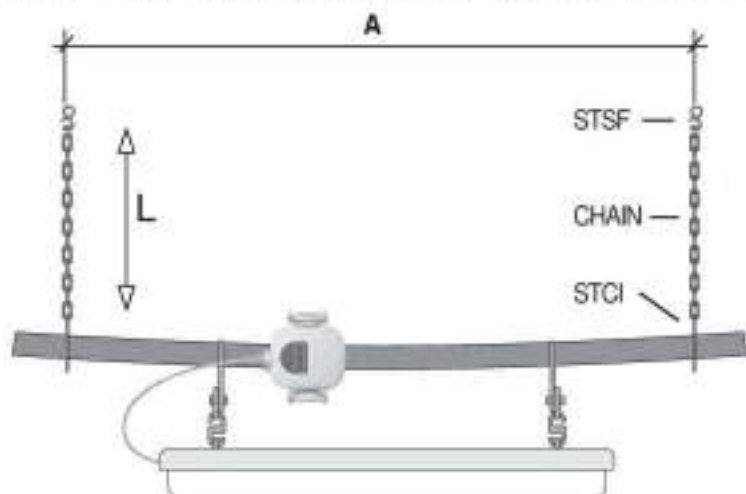

A	L 0-500mm	L 500-1000mm	L 1-2MT	L >2MT
1,5	Kg ▶ ▲ 19	Kg ▶ ▲ 18	Kg ▶ ▲ 17	Kg ▶ ▲ 15
2,0	Kg ▶ ▲ 13	Kg ▶ ▲ 12	Kg ▶ ▲ 11	Kg ▶ ▲ 10
2,5	Kg ▶ ▲ 11	Kg ▶ ▲ 10	Kg ▶ ▲ 9	Kg ▶ ▲ 8
3	Kg ▶ ▲ 7	Kg ▶ ▲ 6	Kg ▶ ▲ 5	Kg ▶ ▲ 5

A - DISTANCE BETWEEN TWO SUSPENSION POINTS
 B - DISTANCE FROM THE CEILING
 KG ▶ ▲ LAMP MAX WEIGHT IN KG
 A - DISTANZA TRA I DUE PUNTI DI SOSPENSIONE
 B - DISTANZA DAL SOFFITTO
 KG ▶ ▲ PESO MASSIMO DELLA LAMPADA IN KG

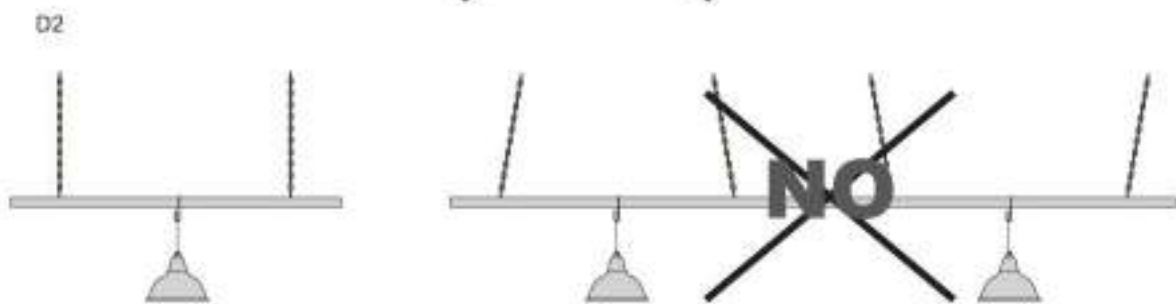
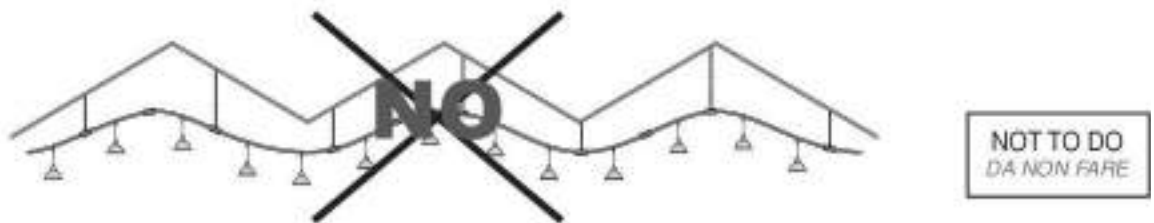
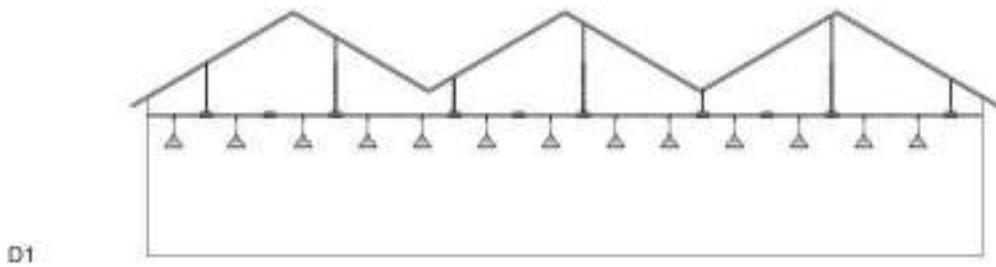
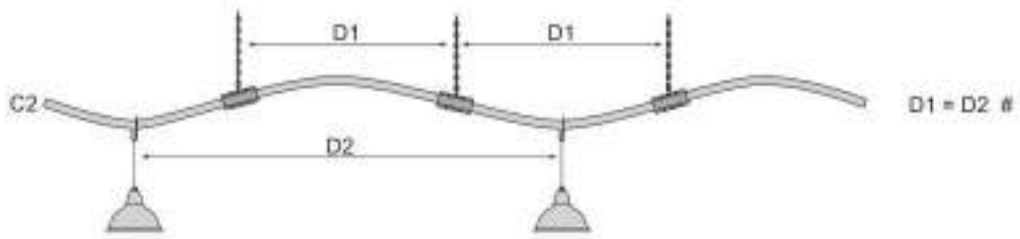
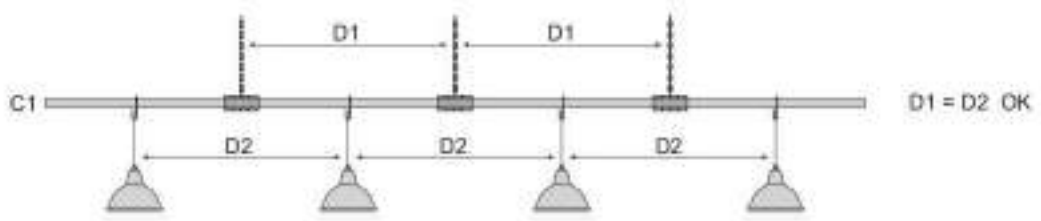

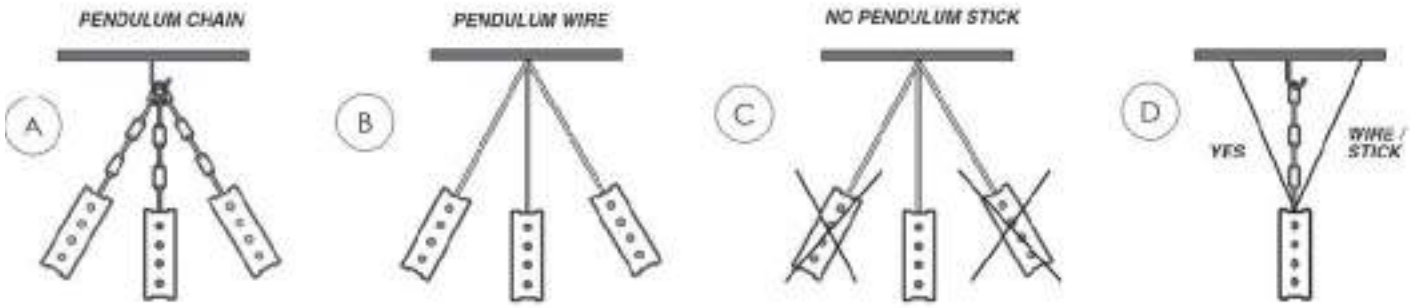

WORSE INSTALLATION

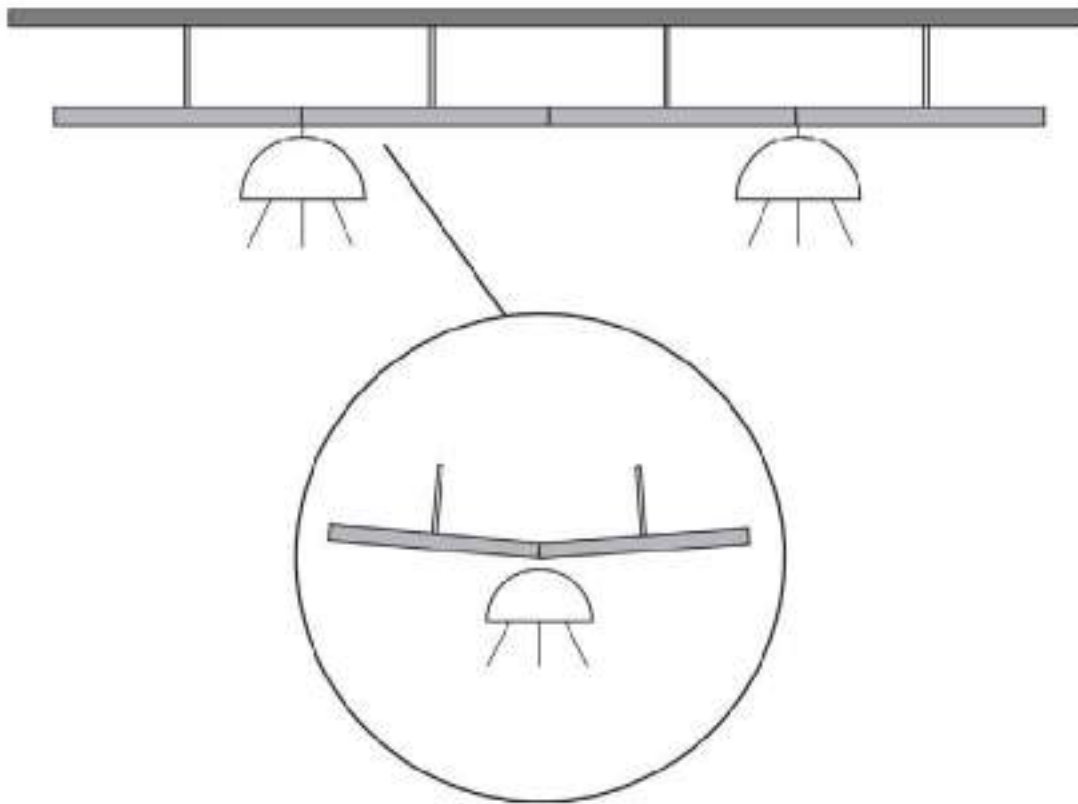

BEST SIMULATION

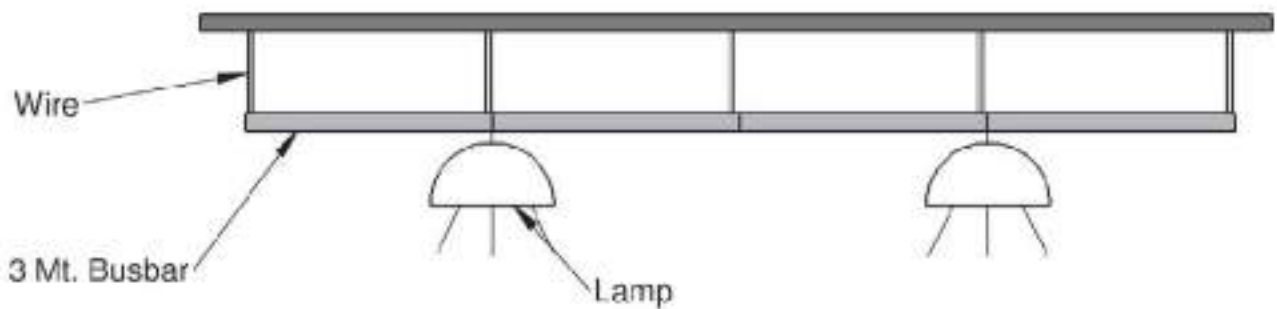

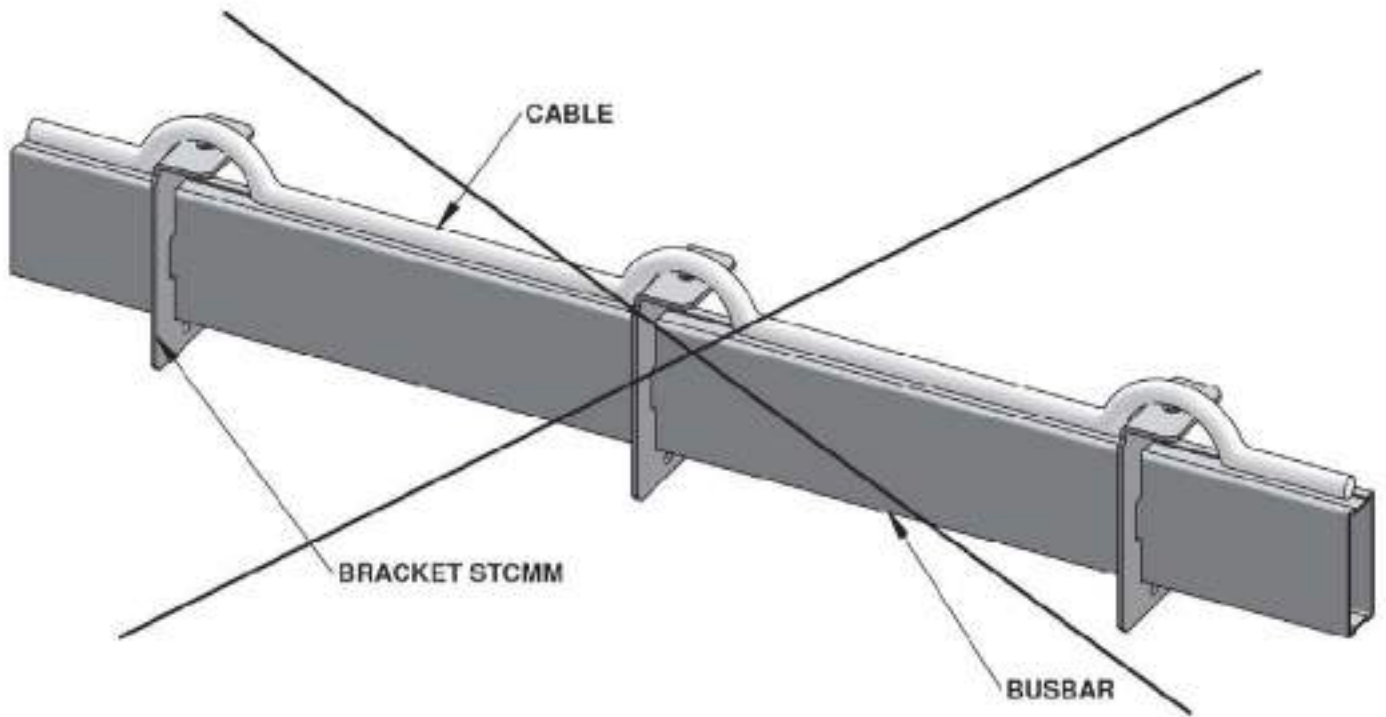

NO!!!

NO USE OF CABLE DIRECTLY LAID ON BUSBAR

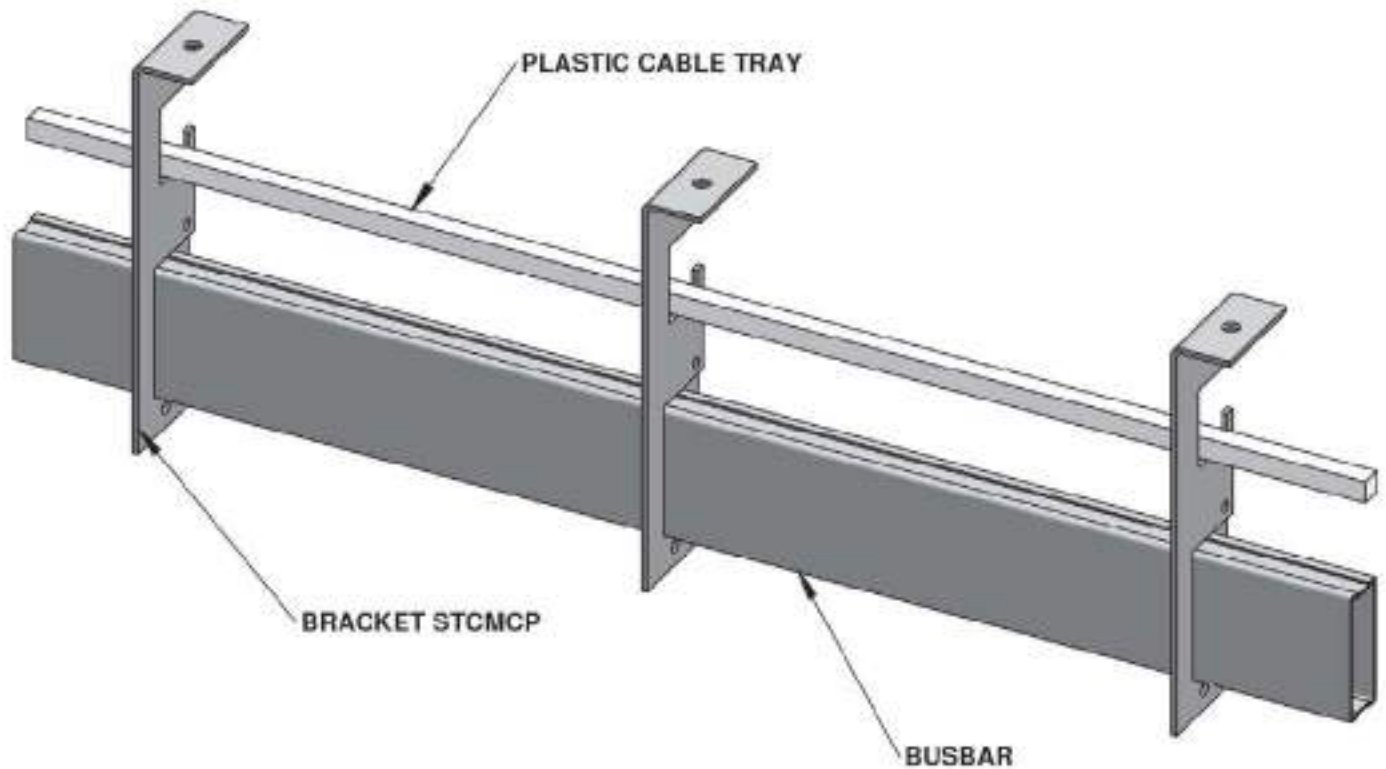

NAXSO UNDERFLOOR

NAXSO LUX



Naxso Underfloor track is a small dimension busbar to let installation in every area where underfloor space is low and the minimal space is requiring a compact, strong and high performing track. The minimum floor dimension can be 48mm. Lengths are available in standard 3 - 1,8 - 1,2 mt so that the storage is reduced to the minimum. Tap offs can be key coded to avoid mistakes and are plugged and removed by compressing side clips and pulling them out. Feed units are provided to feed the tracks thanks to a quick joint. Fixing brackets are already built in the tracks and interax outlets can be 1 mt, 500 mm or 300 mm. A number of accessories as flexible interlinks or intermediate feed units are available.

Il Naxso sottopavimento è una barra di piccole dimensioni per permettere l'installazione in ogni area dove lo spazio di sottopavimento è poco e questa area minima richiede un condotto compatto, robusto ed altamente performante. L'altezza minima del sottopavimento può essere 48mm. Le lunghezze sono disponibili nello standard 3-1,8-1,2 mt affinché lo spazio di stoccaggio sia ridotto al minimo. Le spine possono essere codificate per evitare errori e collegate e rimosse comprimendo delle alette laterali e rilasciandole.

Le alimentazioni sono fornite per alimentare le barre grazie ad una giunzione veloce. Le staffe di fissaggio sono già incorporate con la barra e l'interasse delle finestre possono 1 mt, 500mm o 300mm.

Un numero di accessori come interconnessioni flessibili o alimentazioni intermedie sono disponibili.

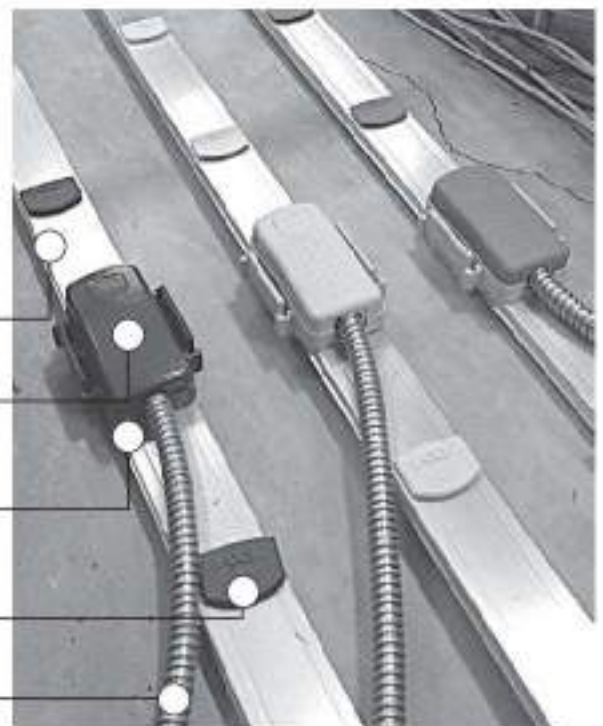



LOW PROFILE BUSBAR HEIGHT

32A TAP-OFFS INCORPORATING AN UNFUSED PLUG

SLIDE LOCKING AND POSITIVE LATCHING

COLOUR CODED FOR EASY RECOGNITION

3 METERS OF 4mm² CABLE

	WHITE BIANCO	ORANGE ARANCIONE	YELLOW LOW NOISE GIALLO BASSO RUMORE	3 PHASE BLUE TRIFASE BLU	DOUBLE C GREY DOPPIO C GRIGIO
	 L ₁ N ₁	 L ₁ N ₁ PE ⊕	 L ₁ N ₁ CE	 L ₃ L ₂ L ₁ N ₁ PE ⊕	 L ₃ N ₁ L ₂ N ₂ CE
TAP OFF 32A UNFUSED CABLE 3 mt 4 m ² Ø 16 mm FLEX METAL CONDUCT 4 m ² CABLES	L N PE SBMLH32	L ₁ N ₁ PE SBMLNPE32	CE L N PE SBMCELNPE32	L ₁ L ₂ L ₃ N PE LN PE SBMLNPE32 SBMLLNPE32	L N PE SBMLNPE32
TAP OFF 13A FUSED CABLE 3 mt 4 m ² Ø 16 mm FLEX METAL CONDUCT	L N PE SBMF13LNPE	L ₁ N ₁ PE SBMF13LNPE	CE L N PE SBMF13CELNPE	L N PE SBMF13LNPE	L N PE CE L N PE SBMF13LNPE SBMF13CELNPE
TAP OFF 13A UNFUSED CABLE 3 mt 4 m ² Ø 16 mm FLEX METAL CONDUCT	L ₁ N ₁ SBMU13LNPE	L ₁ N ₁ PE SBMU13LNPE	CE L N PE SBMU13CELNPE	L N PE SBMU13LNPE	CE L N PE SBMU13CELNPE
FLEX INTERLINK CORNER FLEX METAL CONDUCT Ø 20 mm CABLE 6m ²	L ₁ N ₁ FLXULN	L ₁ N ₁ PE FLXULNPE	L N CE FLXUCELNPE	L L L N PE FLXULLLNPE	L L L N CE FLXULLLCEPE
UNDERFLOOR BUSBAR TRACK 63A ALUMINIUM HOUSE (PE) 1,2 MT JOINT INCLUDED 2 WINDOWS	L ₁ N ₁ L 1,2 mt BA63ULN12	L ₁ N ₁ PE BA63ULNPE12	L N CE BA63UCELNPE12	L L L N PE BA63LLLNPE12	L L L N CE BA63ULN12 BA63UCELNPE12
UNDERFLOOR BUSBAR TRACK 63A ALUMINIUM HOUSE (PE) 2,4 MT JOINT INCLUDED 6 WINDOWS	L ₁ N ₁ L 2,4 mt BA63ULN24	L ₁ N ₁ PE BA63ULNPE24	L N CE BA63UCELNPE24	L L L N PE BA63LLLNPE24	L L L N CE BA63ULN24 BA63UCELNPE24
UNDERFLOOR BUSBAR TRACK 63A ALUMINIUM HOUSE (PE) 3 MT JOINT INCLUDED 10 WINDOWS	L ₁ N ₁ L 3,0 mt BA63ULN30	L ₁ N ₁ PE BA63ULNPE30	L N CE BA63UCELNPE30	L L L N PE BA63LLLNPE30	L L L N CE BA63ULN30 BA63UCELNPE30

All Tap-Offs are reconfigurable minimum cable even in PE is 4m². On demand we can wire and supply 6m² cable. All Tap-Offs are key colour coded and may even be mechanically coded.



BA25A305S

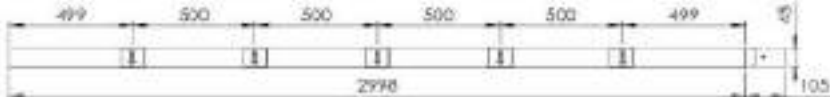
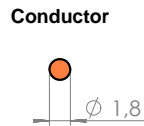
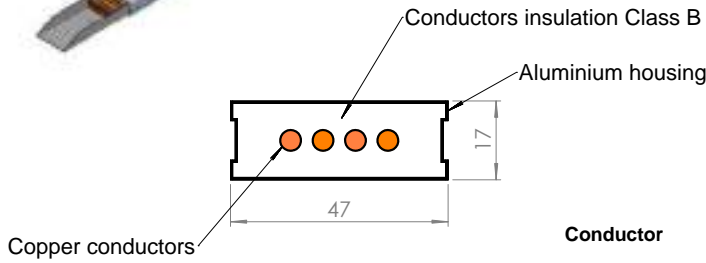
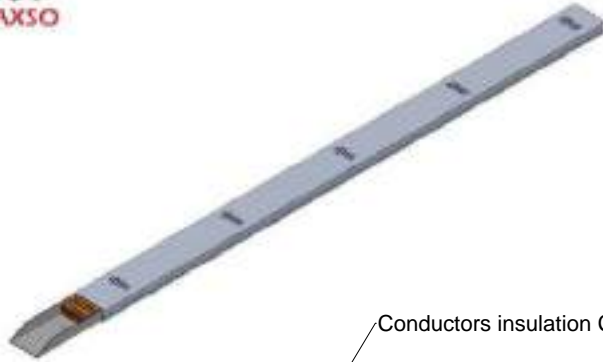

Rated Current	25 A 4P
Protection Degree	IP55
Housing	AL 6060 T6
Weight busbar	1,6 Kg
Dimension	17 X 47 mm
Area (PE) Housing cross section (AL)	115 mm ²
Thickness	0,9 mm
Equivalent in copper	69 mm ²
Perimetral	129 mm
Conductors N included	∅ 1,8 mm
Conductor cross section	2,5 mm ²
Conductors alloy	Copper TIN
Support PVC	
Supports temperature	Class B
Joint support polyamide	Class B
Joint live parts TIN plated	6 mm ²
Labels windows (5)	
Joint frame GI 1,5	90 mm ²
Short-Circuit (Peak) (Ipk)	4,9 kA
Short-Circuit (Peak) Tested 1 msec. (Icw)	2,8 kA
Resistance (R20)	6,7 mΩ/m
Reactance (X)	0,23 mΩ/m
Impedance (Z)	7,7 mΩ/m
Joule losses At In (I2r)	12,6 W/m



BA25A305SDUAL

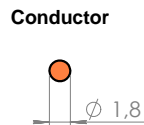
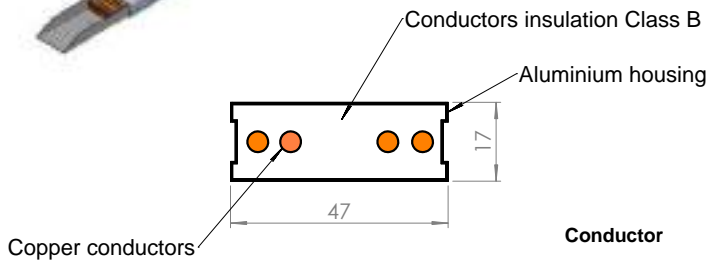
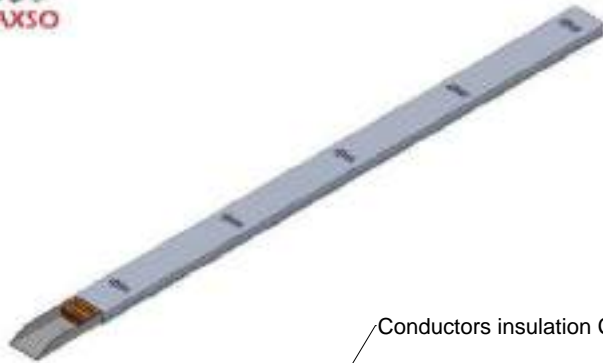

Rated Current	25 A 4P
Protection Degree	IP55
Housing	AL 6060 T6
Weight busbar	1,6 Kg
Dimension	17 X 47 mm
Area (PE) Housing cross section (AL)	115 mm ²
Thickness	0,9 mm
Equivalent in copper	69 mm ²
Perimetral	129 mm
Conductors N included	∅ 1,8 mm
Conductor cross section	2,5 mm ²
Conductors alloy	Copper TIN
Support PVC	
Supports temperature	Class B
Joint support polyamide	Class B
Joint live parts TIN plated	6 mm ²
Labels windows (5)	
Joint frame GI 1,5	90 mm ²
Short-Circuit (Peak) (Ipk)	4,9 kA
Short-Circuit (Peak) Tested 1 msec. (Icw)	2,8 kA
Resistance (R20)	6,7 mΩ/m
Reactance (X)	0,23 mΩ/m
Impedance (Z)	7,7 mΩ/m
Joule losses At In (I2r)	12,6 W/m



BA25A305SS

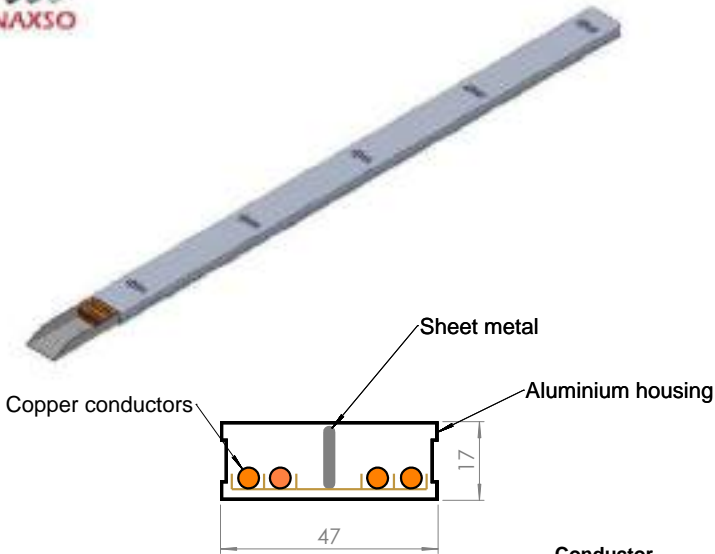

Conductor

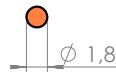

Rated Current	25 A 4P
Protection Degree	IP55
Housing	AL 6060 T6
Weight busbar	2 Kg
Dimension	17 X 47 mm
Area (PE) Housing cross section (AL)	115 mm ²
Thickness	0,9 mm
Equivalent in copper	69 mm ²
Perimetral	129 mm
Conductors N included	∅ 1,8 mm
Conductor cross section	2,5 mm ²
Conductors alloy	Copper TIN
Support PVC	
Supports temperature	Class B
Joint support polyamide	Class B
Joint live parts TIN plated	6 mm ²
Labels windows (5)	
Joint frame GI 1,5	90 mm ²
Short-Circuit (Peak) (I _{pk})	4,9 kA
Short-Circuit (Peak) Tested 1 msec. (I _{cw})	2,8 kA
Resistance (R ₂₀)	6,7 mΩ/m
Reactance (X)	0,23 mΩ/m
Impedance (Z)	7,7 mΩ/m
Joule losses At In (I _{2r})	12,6 W/m



BA25A305ST



Conductor

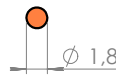

Rated Current	25 A 4P+4P
Protection Degree	IP55
Housing	AL 6060 T6
Weight busbar	3,2 Kg
Dimension	34 X 47 mm
Area (PE) Housing cross section (AL)	115 mm ² x2
Thickness	0,9 mm
Equivalent in copper	69 mm ²
Perimetral	129 mm x2
Conductors N included	∅ 1,8 mm
Conductor cross section	2,5 mm ²
Conductors alloy	Copper TIN
Support PVC	
Supports temperature	Class B
Joint support polyamide	Class B
Joint live parts TIN plated	6 mm ²
Labels windows (5)	
Joint frame GI 1,5	90 mm ²
Short-Circuit (Peak) (I _{pk})	4,9 kA
Short-Circuit (Peak) Tested 1 msec. (I _{cw})	2,8 kA
Resistance (R ₂₀)	6,7 mΩ/m
Reactance (X)	0,23 mΩ/m
Impedance (Z)	7,7 mΩ/m
Joule losses At In (I _{2r})	12,6 W/m



BA25A3025S

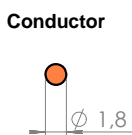
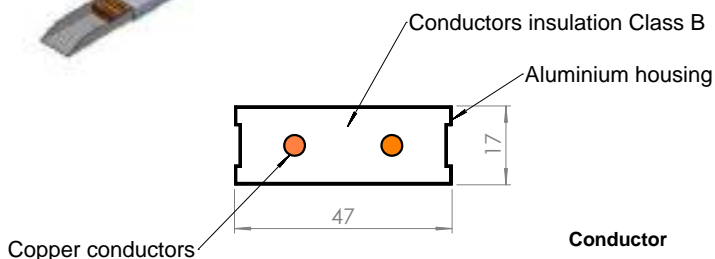
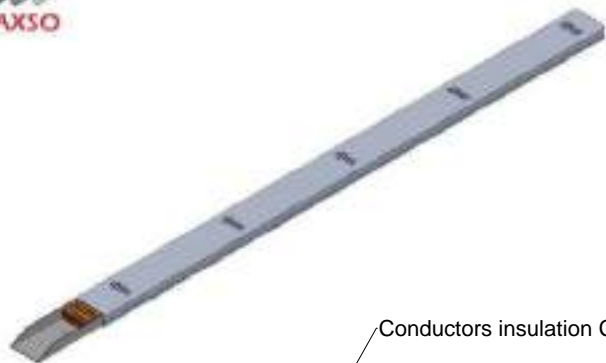

Rated Current	25 A 2P
Protection Degree	IP55
Housing	AL 6060 T6
Weight busbar	1,2 Kg
Dimension	17 X 47 mm
Area (PE) Housing cross section (AL)	115 mm ²
Thickness	0,9 mm
Equivalent in copper	69 mm ²
Perimetral	129 mm
Conductors N included	∅ 1,8 mm
Conductor cross section	2,5 mm ²
Conductors alloy	Copper TIN
Support PVC	
Supports temperature	Class B
Joint support polyamide	Class B
Joint live parts TIN plated	6 mm ²
Labels windows (5)	
Joint frame GI 1,5	90 mm ²
Short-Circuit (Peak) (Ipk)	4,9 kA
Short-Circuit (Peak) Tested 1 msec. (Icw)	2,8 kA
Resistance (R20)	6,7 mΩ/m
Reactance (X)	0,23 mΩ/m
Impedance (Z)	7,7 mΩ/m
Joule losses At In (I2r)	12,6 W/m



BA25A3025ST

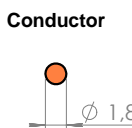
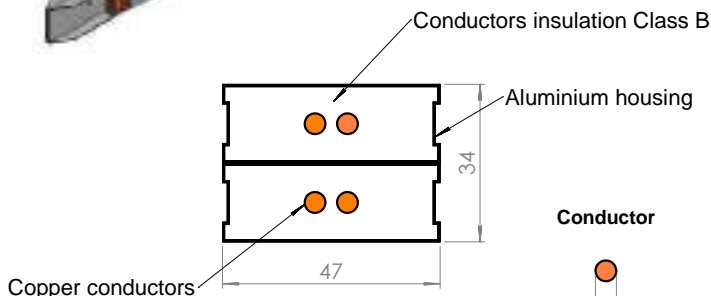
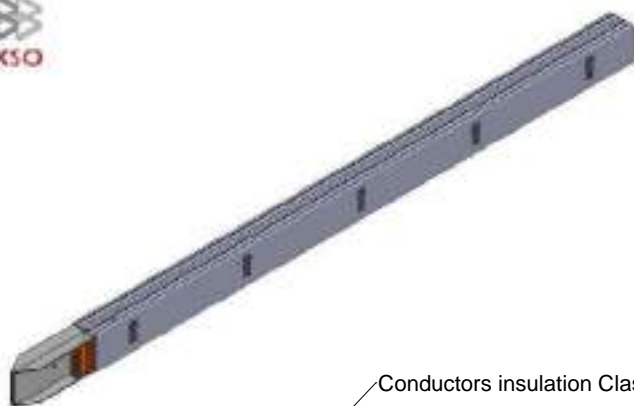

Rated Current	25 A 2P+2P
Protection Degree	IP55
Housing	AL 6060 T6
Weight busbar	2,4 Kg
Dimension	34 X 47 mm
Area (PE) Housing cross section (AL)	115 mm ² x2
Thickness	0,9 mm
Equivalent in copper	69 mm ²
Perimetral	129 mm x2
Conductors N included	∅ 1,8 mm
Conductor cross section	2,5 mm ²
Conductors alloy	Copper TIN
Support PVC	
Supports temperature	Class B
Joint support polyamide	Class B
Joint live parts TIN plated	6 mm ²
Labels windows (5)	
Joint frame GI 1,5	90 mm ²
Short-Circuit (Peak) (Ipk)	4,9 kA
Short-Circuit (Peak) Tested 1 msec. (Icw)	2,8 kA
Resistance (R20)	6,7 mΩ/m
Reactance (X)	0,23 mΩ/m
Impedance (Z)	7,7 mΩ/m
Joule losses At In (I2r)	12,6 W/m

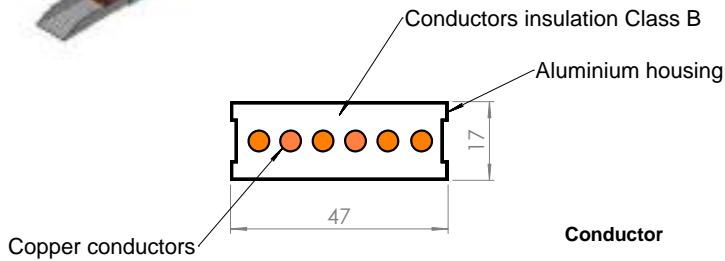
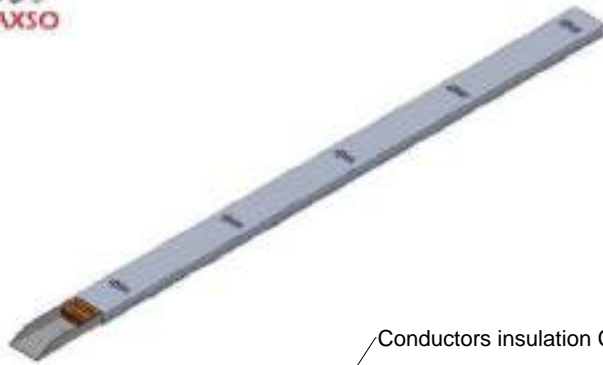

Conductor

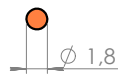

BA25A3065S

Rated Current	25 A 6P
Protection Degree	IP55
Housing	AL 6060 T6
Weight busbar	2 Kg
Dimension	17 X 47 mm
Area (PE) Housing cross section (AL)	115 mm ²
Thickness	0,9 mm
Equivalent in copper	69 mm ²
Perimetral	129 mm
Conductors N included	∅ 1,8 mm
Conductor cross section	2,5 mm ²
Conductors alloy	Copper TIN
Support PVC	
Supports temperature	Class B
Joint support polyamide	Class B
Joint live parts TIN plated	6 mm ²
Labels windows (5)	
Joint frame GI 1,5	90 mm ²
Short-Circuit (Peak) (I _{pk})	4,9 kA
Short-Circuit (Peak) Tested 1 msec. (I _{cw})	2,8 kA
Resistance (R ₂₀)	6,7 mΩ/m
Reactance (X)	0,23 mΩ/m
Impedance (Z)	7,7 mΩ/m
Joule losses At In (I _{2r})	12,6 W/m

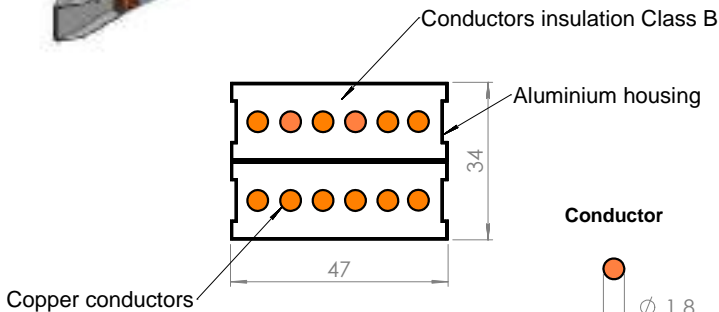
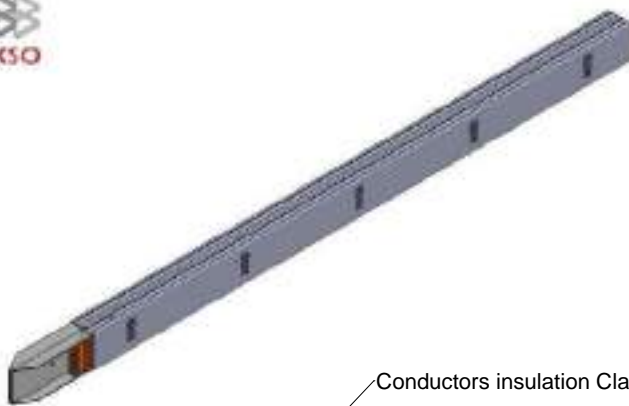

Conductor

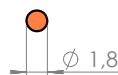

BA25A3065ST

Rated Current	25 A 6P+6P
Protection Degree	IP55
Housing	AL 6060 T6
Weight busbar	4 Kg
Dimension	34 X 47 mm
Area (PE) Housing cross section (AL)	115 mm ² x2
Thickness	0,9 mm
Equivalent in copper	69 mm ²
Perimetral	129 mm x2
Conductors N included	∅ 1,8 mm
Conductor cross section	2,5 mm ²
Conductors alloy	Copper TIN
Support PVC	
Supports temperature	Class B
Joint support polyamide	Class B
Joint live parts TIN plated	6 mm ²
Labels windows (5)	
Joint frame GI 1,5	90 mm ²
Short-Circuit (Peak) (I _{pk})	4,9 kA
Short-Circuit (Peak) Tested 1 msec. (I _{cw})	2,8 kA
Resistance (R ₂₀)	6,7 mΩ/m
Reactance (X)	0,23 mΩ/m
Impedance (Z)	7,7 mΩ/m
Joule losses At In (I _{2r})	12,6 W/m



BA40A305S

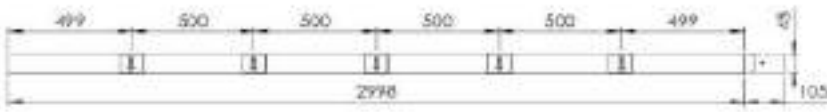
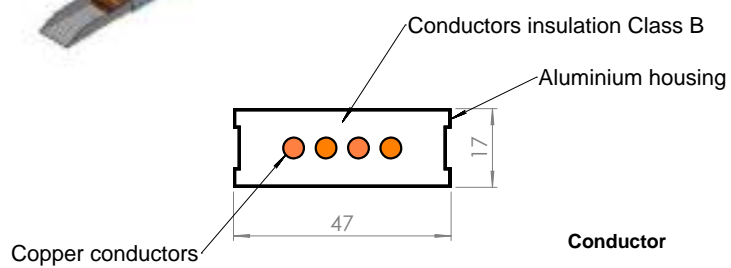

Rated Current	40 A 4P
Protection Degree	IP55
Housing	AL 6060 T6
Weight busbar	2,2 Kg
Dimension	17 X 47 mm
Area (PE) Housing cross section (AL)	115 mm ²
Thickness	0,9 mm
Equivalent in copper	69 mm ²
Perimetral	129 mm
Conductors N included	ϕ 2,5 mm
Conductor cross section	6 mm ²
Conductors alloy	Copper TIN
Support PVC	
Supports temperature	Class B
Joint support polyamide	Class B
Joint live parts TIN plated	6 mm ²
Labels windows (5)	
Joint frame GI 1,5	90 mm ²
Short-Circuit (Peak) (Ipk)	5,3 kA
Short-Circuit (Peak) Tested 1 msec. (Icw)	3 kA
Resistance (R20)	3,2 m Ω /m
Reactance (X)	0,24 m Ω /m
Impedance (Z)	3,2 m Ω /m
Joule losses At In (I2r)	15,2 W/m



BA40A305ST

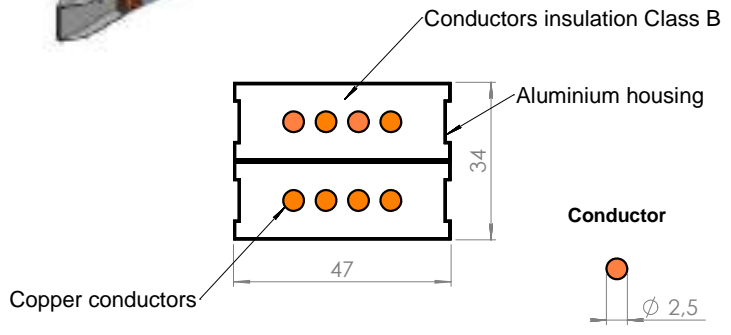
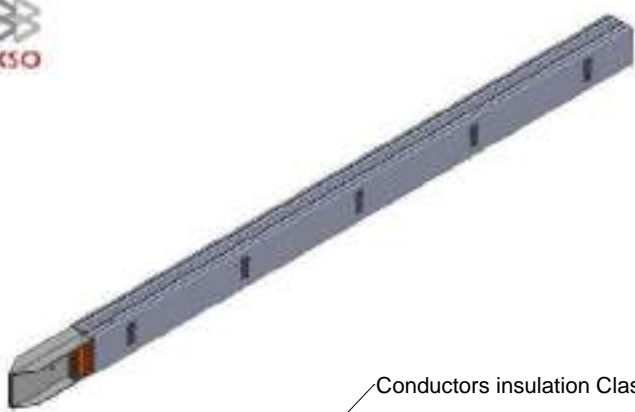

Rated Current	40 A 4P+4P
Protection Degree	IP55
Housing	AL 6060 T6
Weight busbar	4,4 Kg
Dimension	34 X 47 mm
Area (PE) Housing cross section (AL)	115 mm ² x2
Thickness	0,9 mm
Equivalent in copper	69 mm ²
Perimetral	129 mm x2
Conductors N included	ϕ 2,5 mm
Conductor cross section	6 mm ²
Conductors alloy	Copper TIN
Support PVC	
Supports temperature	Class B
Joint support polyamide	Class B
Joint live parts TIN plated	6 mm ²
Labels windows (5)	
Joint frame GI 1,5	90 mm ²
Short-Circuit (Peak) (Ipk)	5,3 kA
Short-Circuit (Peak) Tested 1 msec. (Icw)	3 kA
Resistance (R20)	3,2 m Ω /m
Reactance (X)	0,24 m Ω /m
Impedance (Z)	3,2 m Ω /m
Joule losses At In (I2r)	15,2 W/m

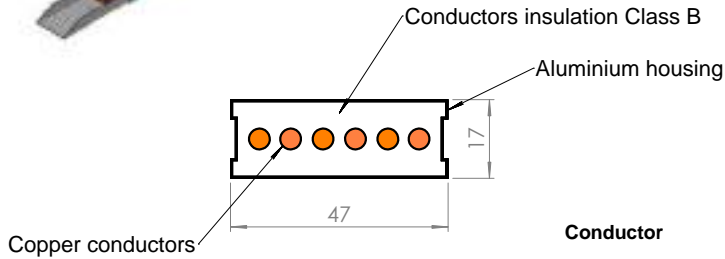
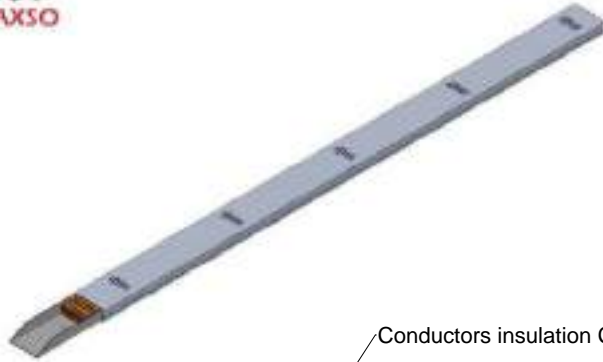

Conductor

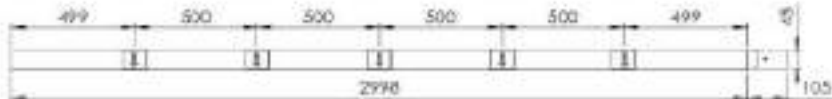
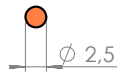

BA40A3065S

Rated Current	40 A 6P
Protection Degree	IP55
Housing	AL 6060 T6
Weight busbar	2,6 Kg
Dimension	17 X 47 mm
Area (PE) Housing cross section (AL)	115 mm ²
Thickness	0,9 mm
Equivalent in copper	69 mm ²
Perimetral	129 mm
Conductors N included	∅ 2,5 mm
Conductor cross section	6 mm ²
Conductors alloy	Copper TIN
Support PVC	
Supports temperature	Class B
Joint support polyamide	Class B
Joint live parts TIN plated	6 mm ²
Labels windows (5)	
Joint frame GI 1,5	90 mm ²
Short-Circuit (Peak) (I _{pk})	5,3 kA
Short-Circuit (Peak) Tested 1 msec. (I _{cw})	3 kA
Resistance (R ₂₀)	3,2 mΩ/m
Reactance (X)	0,24 mΩ/m
Impedance (Z)	3,2 mΩ/m
Joule losses At In (I _{2r})	15,2 W/m

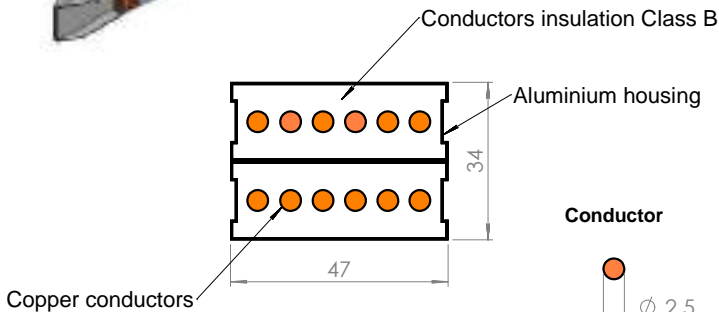
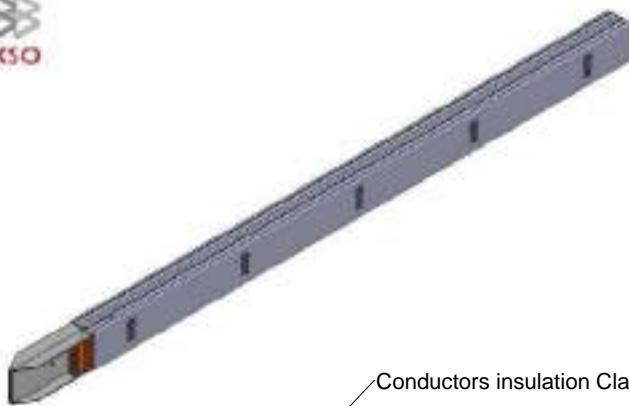

Conductor

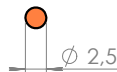

BA40A3065ST

Rated Current	40 A 6P+6P
Protection Degree	IP55
Housing	AL 6060 T6
Weight busbar	5,2 Kg
Dimension	34 X 47 mm
Area (PE) Housing cross section (AL)	115 mm ² x2
Thickness	0,9 mm
Equivalent in copper	69 mm ²
Perimetral	129 mm x2
Conductors N included	∅ 2,5 mm
Conductor cross section	6 mm ²
Conductors alloy	Copper TIN
Support PVC	
Supports temperature	Class B
Joint support polyamide	Class B
Joint live parts TIN plated	6 mm ²
Labels windows (5)	
Joint frame GI 1,5	90 mm ²
Short-Circuit (Peak) (I _{pk})	5,3 kA
Short-Circuit (Peak) Tested 1 msec. (I _{cw})	3 kA
Resistance (R ₂₀)	3,2 mΩ/m
Reactance (X)	0,24 mΩ/m
Impedance (Z)	3,2 mΩ/m
Joule losses At In (I _{2r})	15,2 W/m

NAXSO LUX

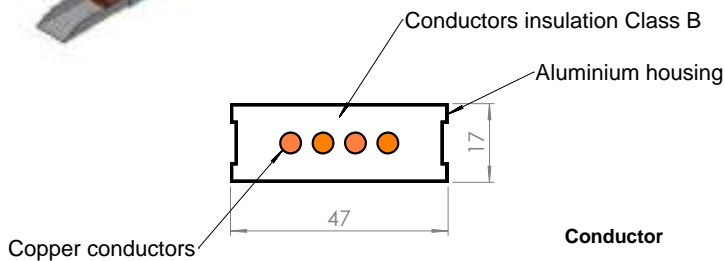
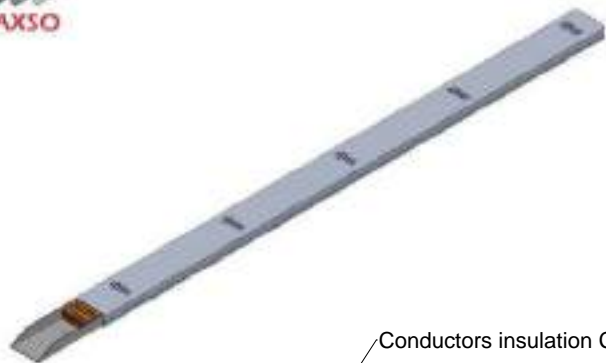

Conductor

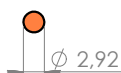

BA63A305S

Rated Current	63 A 4P
Protection Degree	IP55
Housing	AL 6060 T6
Weight busbar	3,4 Kg
Dimension	17 X 47 mm
Area (PE) Housing cross section (AL)	115 mm ²
Thickness	0,9 mm
Equivalent in copper	69 mm ²
Perimetral	129 mm
Conductors N included	ϕ 2,92 mm
Conductor cross section	6,7 mm ²
Conductors alloy	Copper TIN
Support PVC	
Supports temperature	Class B
Joint support polyamide	Class B
Joint live parts TIN plated	11 mm ²
Labels windows (5)	
Joint frame GI 1,5	90 mm ²
Short-Circuit (Peak) (Ipk)	7 kA
Short-Circuit (Peak) Tested 1 msec. (Icw)	4 kA
Resistance (R20)	1,4 m Ω /m
Reactance (X)	0,24 m Ω /m
Impedance (Z)	1,4 m Ω /m
Joule losses At In (I2r)	16,7 W/m

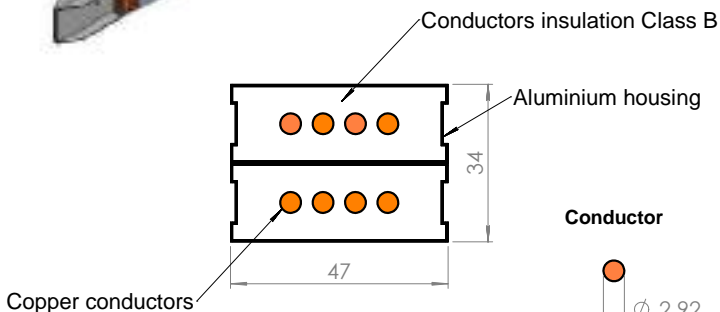
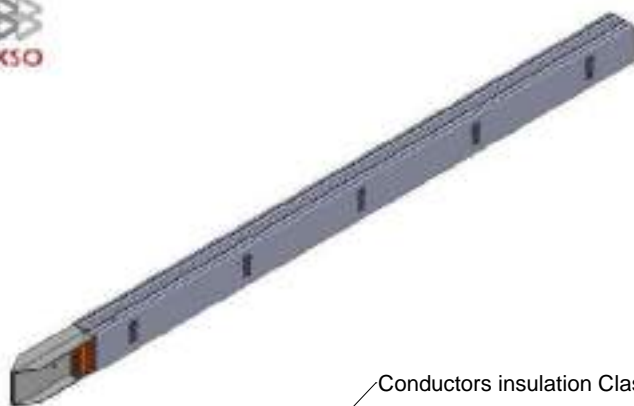

Conductor

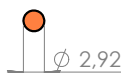

BA63A305ST

Rated Current	63 A 4P+4P
Protection Degree	IP55
Housing	AL 6060 T6
Weight busbar	6,8 Kg
Dimension	34 X 47 mm
Area (PE) Housing cross section (AL)	115 mm ² x2
Thickness	0,9 mm
Equivalent in copper	69 mm ²
Perimetral	129 mm x2
Conductors N included	ϕ 2,92 mm
Conductor cross section	6 mm ²
Conductors alloy	Copper TIN
Support PVC	
Supports temperature	Class B
Joint support polyamide	Class B
Joint live parts TIN plated	6 mm ²
Labels windows (5)	
Joint frame GI 1,5	90 mm ²
Short-Circuit (Peak) (Ipk)	7 kA
Short-Circuit (Peak) Tested 1 msec. (Icw)	4 kA
Resistance (R20)	1,4 m Ω /m
Reactance (X)	0,24 m Ω /m
Impedance (Z)	1,4 m Ω /m
Joule losses At In (I2r)	16,7 W/m

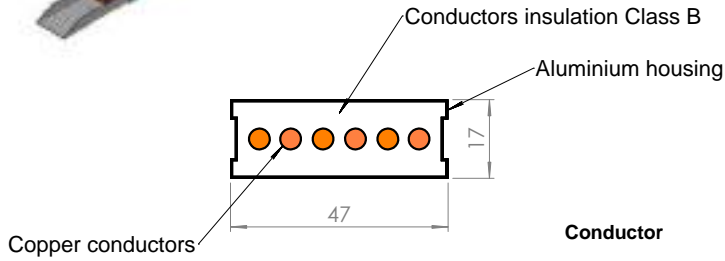
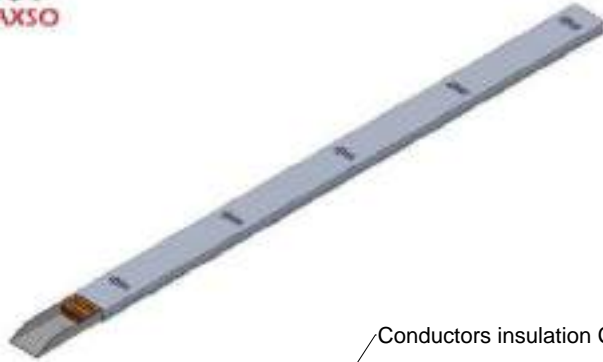

Conductor

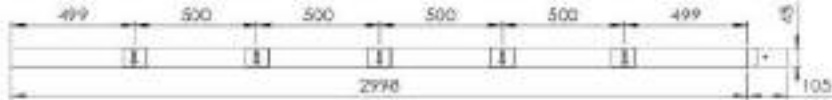
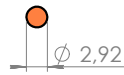

BA63A3065S

Rated Current	63 A 6P
Protection Degree	IP55
Housing	AL 6060 T6
Weight busbar	4 Kg
Dimension	17 X 47 mm
Area (PE) Housing cross section (AL)	115 mm ²
Thickness	0,9 mm
Equivalent in copper	69 mm ²
Perimetral	129 mm
Conductors N included	∅ 2,92 mm
Conductor cross section	6,7 mm ²
Conductors alloy	Copper TIN
Support PVC	
Supports temperature	Class B
Joint support polyamide	Class B
Joint live parts TIN plated	11 mm ²
Labels windows (5)	
Joint frame GI 1,5	90 mm ²
Short-Circuit (Peak) (Ipk)	7 kA
Short-Circuit (Peak) Tested 1 msec. (Icw)	4 kA
Resistance (R20)	1,4 mΩ/m
Reactance (X)	0,24 mΩ/m
Impedance (Z)	1,4 mΩ/m
Joule losses At In (I2r)	16,7 W/m

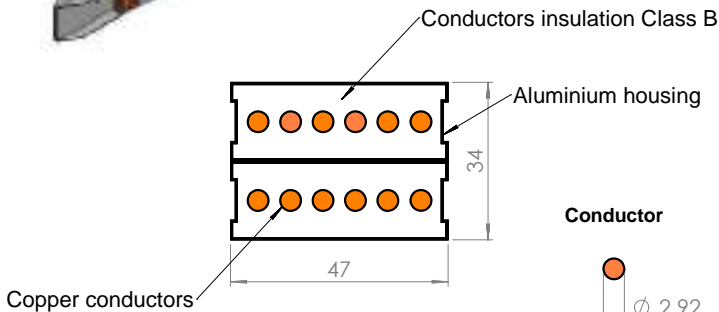
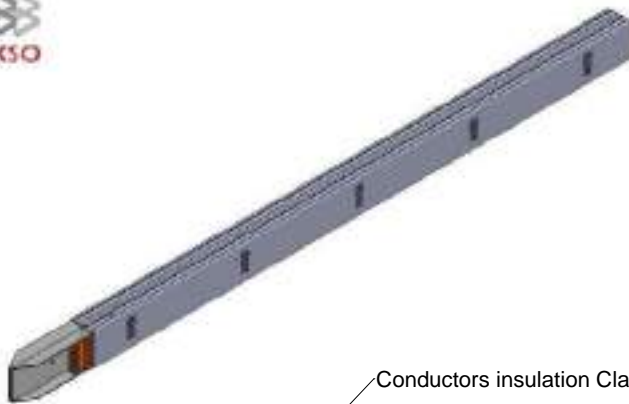

Conductor

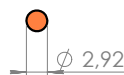

BA63A3065ST

Rated Current	63 A 6P+6P
Protection Degree	IP55
Housing	AL 6060 T6
Weight busbar	8 Kg
Dimension	34 X 47 mm
Area (PE) Housing cross section (AL)	115 mm ² x2
Thickness	0,9 mm
Equivalent in copper	69 mm ²
Perimetral	129 mm x2
Conductors N included	∅ 2,92 mm
Conductor cross section	6 mm ²
Conductors alloy	Copper TIN
Support PVC	
Supports temperature	Class B
Joint support polyamide	Class B
Joint live parts TIN plated	6 mm ²
Labels windows (5)	
Joint frame GI 1,5	90 mm ²
Short-Circuit (Peak) (Ipk)	7 kA
Short-Circuit (Peak) Tested 1 msec. (Icw)	4 kA
Resistance (R20)	1,4 mΩ/m
Reactance (X)	0,24 mΩ/m
Impedance (Z)	1,4 mΩ/m
Joule losses At In (I2r)	16,7 W/m



TASXBPG 250ACC

FEED UNIT END CUP INCLUDED
CHIUSURA DI TESTATA INCLUSA

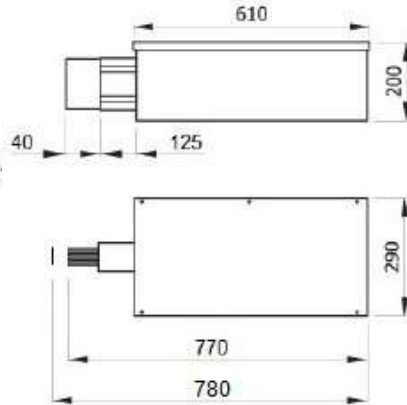

DETAIL OF DRILLING
INTERNAL BAR

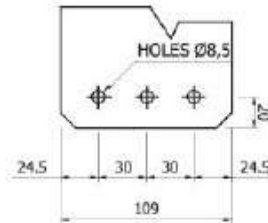

3P + N + PE
AMP 250 A
IP 41 - *IP 55
14,200
67,20 Dm ³ VOLUME AFTER PACKING VOLUME IMBALLATO



TADXBPG 250ACC

FEED UNIT END CUP INCLUDED
CHIUSURA DI TESTATA INCLUSA

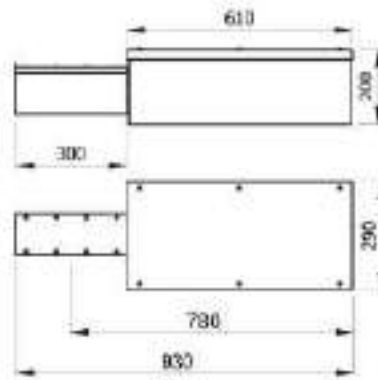

DETAIL OF DRILLING
INTERNAL BAR

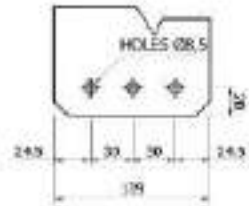

3P + N + PE
AMP 250 A
IP 41 - *IP 55
15,000
67,20 Dm ³ VOLUME AFTER PACKING VOLUME IMBALLATO



TASXBPG 400ACC

FEED UNIT END CUP INCLUDED
CHIUSURA DI TESTATA INCLUSA

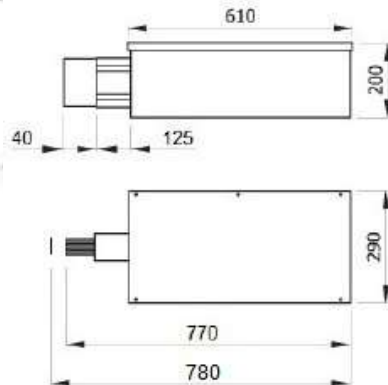

DETAIL OF DRILLING
INTERNAL BAR

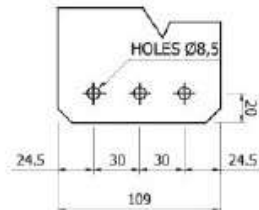

3P + N + PE
AMP 400 A
IP 41 - *IP 55
13,550
67,20 Dm ³ VOLUME AFTER PACKING VOLUME IMBALLATO



TADXBPG 400ACC

FEED UNIT END CUP INCLUDED
CHIUSURA DI TESTATA INCLUSA

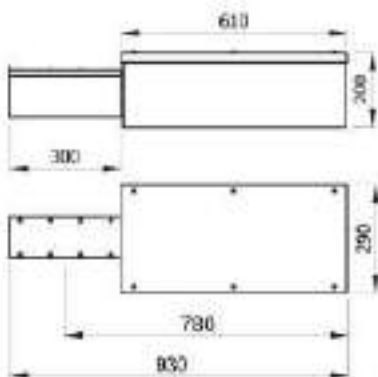

DETAIL OF DRILLING
INTERNAL BAR

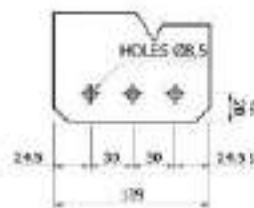

3P + N + PE
AMP 400 A
IP 41 - *IP 55
17,250
67,20 Dm ³ VOLUME AFTER PACKING VOLUME IMBALLATO



TASXBPG 630ACC

FEED UNIT END CUP INCLUDED
CHIUSURA DI TESTATA INCLUSA

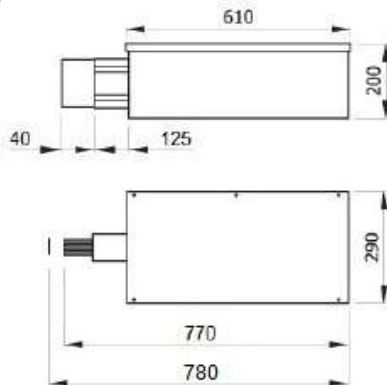

DETAIL OF DRILLING
INTERNAL BAR

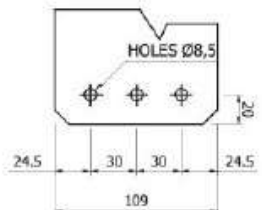

3P + N + PE
AMP 630 A
IP 41 - *IP 55
17,690
67,20 Dm ³ VOLUME AFTER PACKING VOLUME IMBALLATO



TADXBPG 630ACC

FEED UNIT END CUP INCLUDED
CHIUSURA DI TESTATA INCLUSA

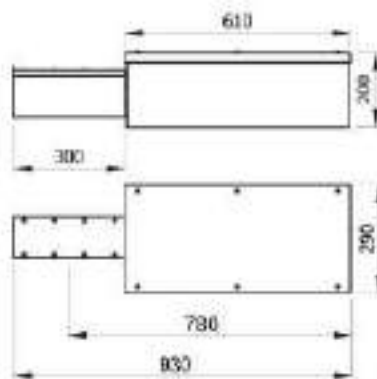

DETAIL OF DRILLING
INTERNAL BAR

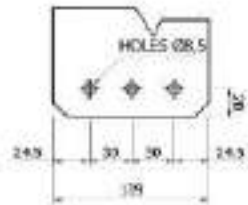

3P + N + PE
AMP 630 A
IP 41 - *IP 55
17,690
67,20 Dm ³ VOLUME AFTER PACKING VOLUME IMBALLATO



TASXBPG 800ACC

FEED UNIT END CUP INCLUDED
CHIUSURA DI TESTATA INCLUSA

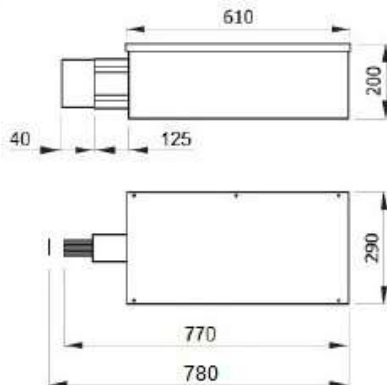

DETAIL OF DRILLING
INTERNAL BAR

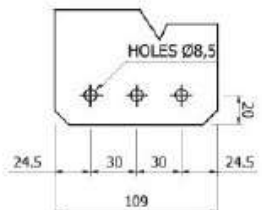

3P + N + PE
AMP 800 A
IP 41 - *IP 55
16,000
67,20 Dm ³ VOLUME AFTER PACKING VOLUME IMBALLATO



TADXBPG 800ACC

FEED UNIT END CUP INCLUDED
CHIUSURA DI TESTATA INCLUSA

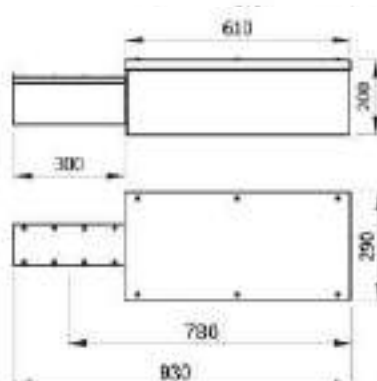

DETAIL OF DRILLING
INTERNAL BAR

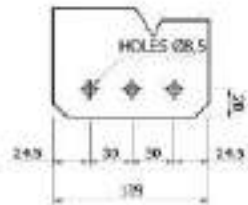

3P + N + PE
AMP 800 A
IP 41 - *IP 55
18,000
67,20 Dm ³ VOLUME AFTER PACKING VOLUME IMBALLATO



NAXSOPOWER

NAXSOPOWER

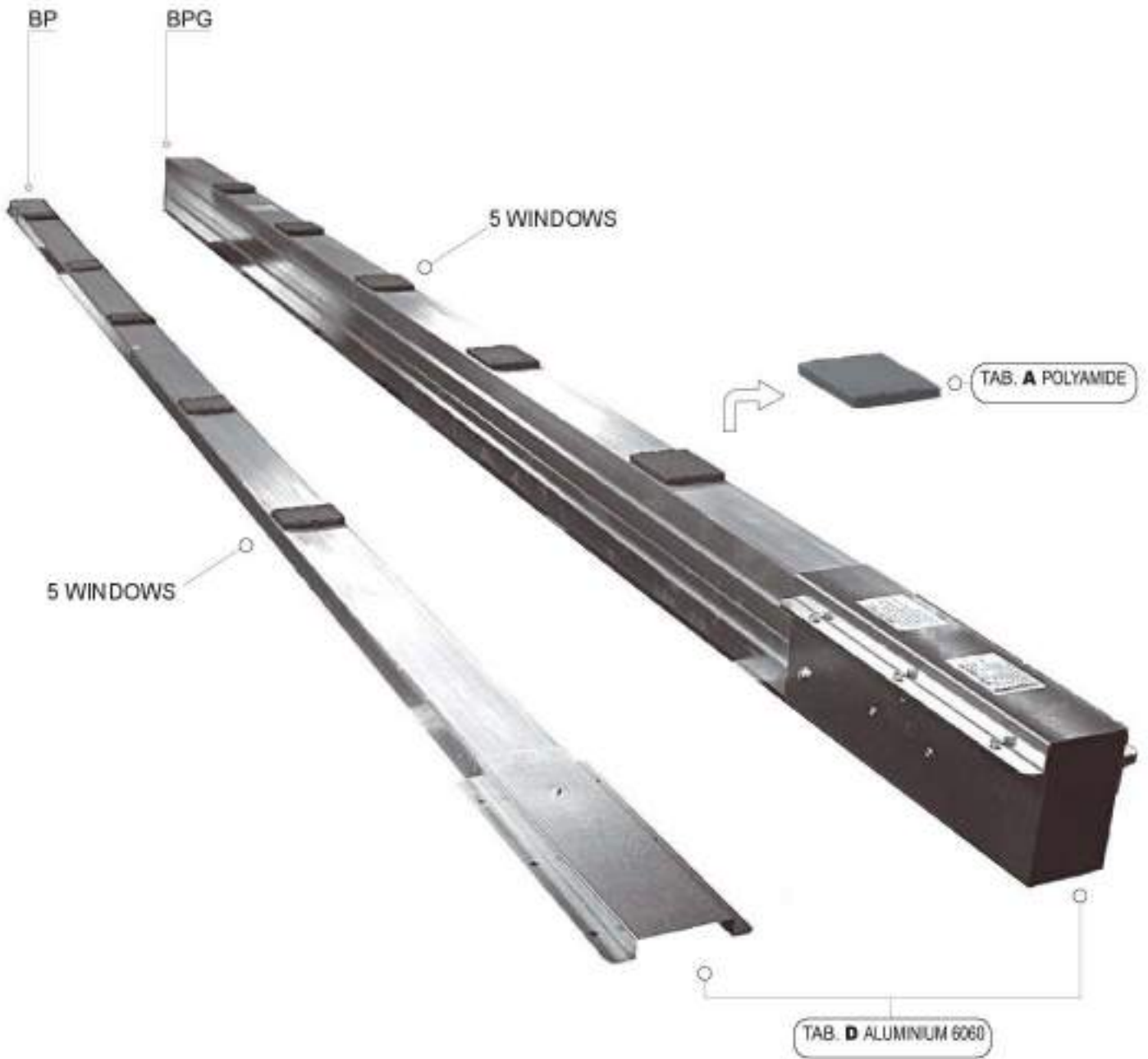

BP AND BPG BUSBARS POWER

BP BUSBAR POWER

- BP40A30 3MT 40A 5 OUTLETS*
- BP40A10 1MT 40A 1 OUTLET*
- BP63A30 3MT 63A 5 OUTLETS*
- BP63A10 1MT 63A 1 OUTLET*
- BP100A30 3MT 100A 5 OUTLETS*
- BP100A10 1MT 100A 1 OUTLET*
- BP160A30 3MT 160A 5 OUTLETS*
- BP160A10 1MT 160A 1 OUTLET*
- BP250A30 3MT 250A 5 OUTLETS*
- BP250A10 1MT 250A 1 OUTLET*

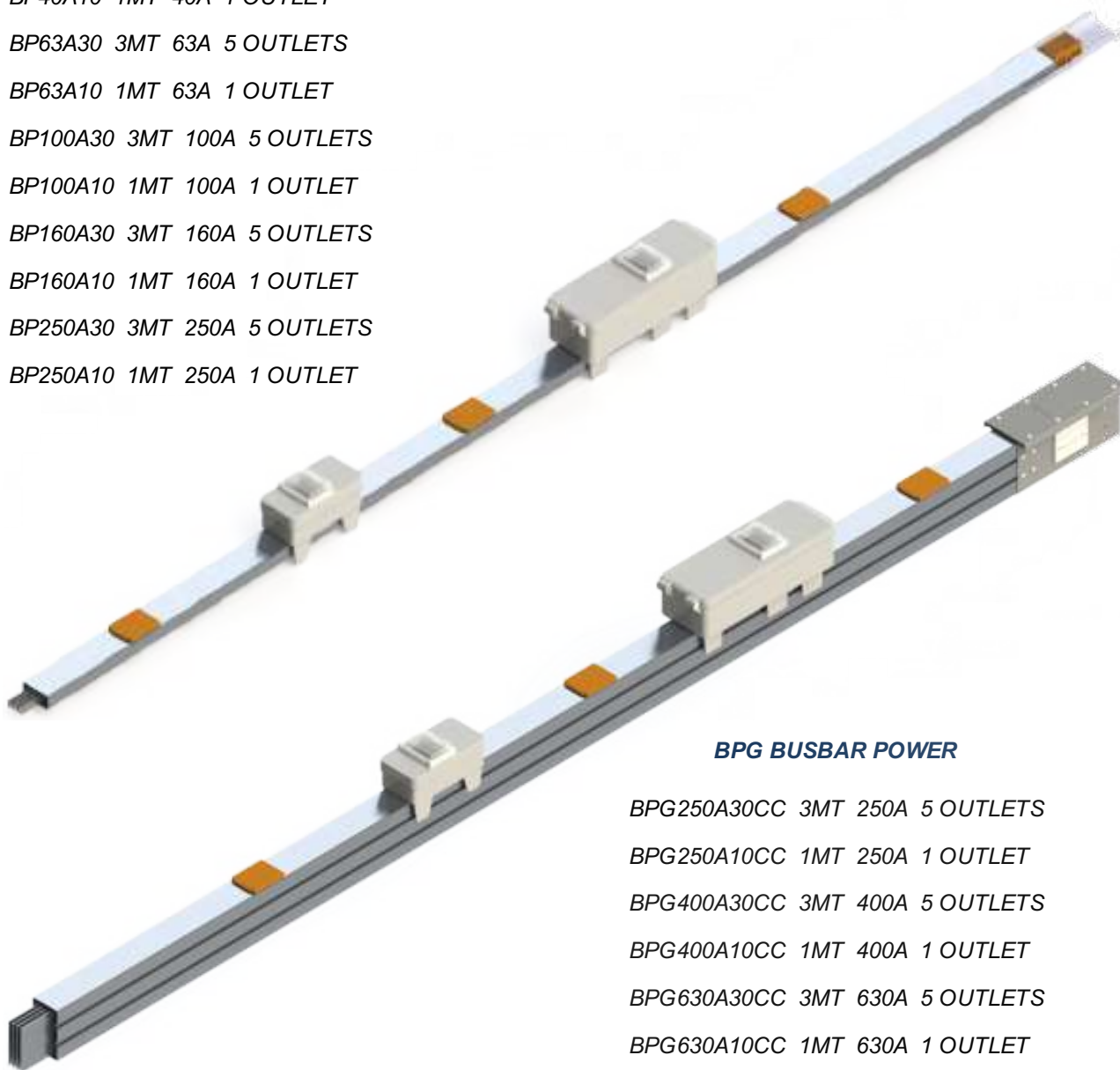

BPG BUSBAR POWER

- BPG250A30CC 3MT 250A 5 OUTLETS*
- BPG250A10CC 1MT 250A 1 OUTLET*
- BPG400A30CC 3MT 400A 5 OUTLETS*
- BPG400A10CC 1MT 400A 1 OUTLET*
- BPG630A30CC 3MT 630A 5 OUTLETS*
- BPG630A10CC 1MT 630A 1 OUTLET*
- BPG800A30CC 3MT 800A 5 OUTLETS*
- BPG800A10CC 1MT 800A 1 OUTLET*
- BPG1000A30CC 3MT 1000A 5 OUTLETS*
- BPG1000A10CC 1MT 1000A 1 OUTLET*
- BPG1250A30CC 3MT 1250A 5 OUTLETS*
- BPG1250A10CC 1MT 1250A 1 OUTLET*

TASX

TADX

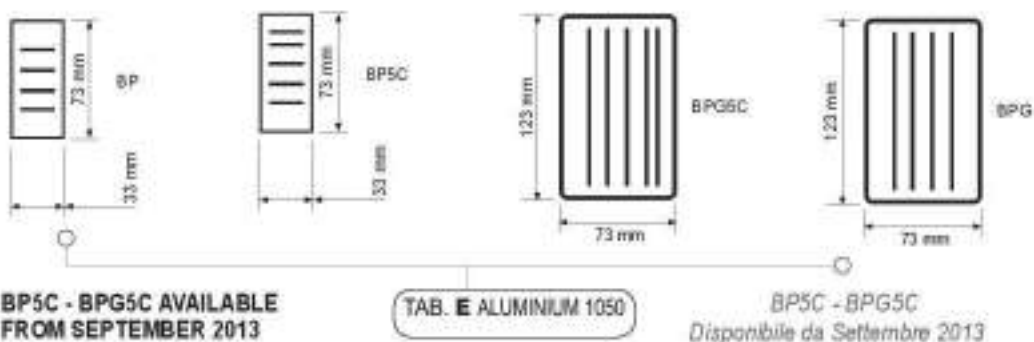

ALLUMINIO / ALUMINIUM

Cod.	Kg	L/mm	AMP
BPG250A30CC	16,25	3.000	250
BPG250A10CC	7,36	1.000	250
BPG400A30CC	18,26	1.000	400
BPG400A10CC	9,30	3.000	400
BPG630A30CC	21,15	3.000	630
BPG630A10CC	10,52	1.000	630
BPG800A30CC	24,20	3.000	800
BPG800A10CC	11,80	1.000	800
BPG1000A30CC	32,00	3.000	1000
BPG1000A10CC	13,00	1.000	1000

Cod.	Kg	L/mm	AMP
BP40A30	4,40	3.000	40
BP40A10	1,50	1.000	40
BP63A30	4,50	3.000	63
BP63A10	2,20	1.000	63
BP100A30	4,60	3.000	100
BP100A10	2,10	1.000	100
BP160A30	5,37	3.000	160
BP160A10	2,50	1.000	160
BP250A30	8,40	3.000	250
BP250A10	3,90	1.000	250

RAME / COPPER

Cod.	Kg	L/mm	AMP
BPG250A30CU	22,75	3.000	250
BPG250A10CU	10,30	1.000	250
BPG400A30CU	25,56	1.000	400
BPG400A10CU	13,02	3.000	400
BPG630A30CU	29,61	3.000	630
BPG630A10CU	14,73	1.000	630
BPG800A30CU	33,88	3.000	800
BPG800A10CU	16,52	1.000	800
BPG1000A30CU	44,80	3.000	1000
BPG1000A10CU	18,20	1.000	1000
BPG1250A30CU	52,20	1.000	1250
BPG1250A10CU	22,50	3.000	1250

Cod.	Kg	L/mm	AMP
BP40A30CU	6,16	3.000	40
BP40A10CU	2,10	1.000	40
BP63A30CU	6,30	3.000	63
BP63A10CU	3,08	1.000	63
BP100A30CU	6,44	3.000	100
BP100A10CU	2,94	1.000	100
BP160A30CU	7,52	3.000	160
BP160A10CU	3,50	1.000	160

 **BP 40 / 63 / 100 / 160 / 250 A10-30**



GENERAL DESCRIPTION DESCRIZIONE GENERALE

4 aluminium conductors aluminium housing boltless flanged joint to get a sturdy installation outlet windows every 3 MT to let plug up to 100A tap-off rating.

4 conduttori in alluminio involucro in alluminio, giunzione automatica finestre su una sola facciata. Per totali 5 finestre grandi (max 100A)

40-250A 5 plugs on one side

MAX TAP-OFF 100A

 **BPG 250 / 400 / 630 / 800 / 1000 A10-30**

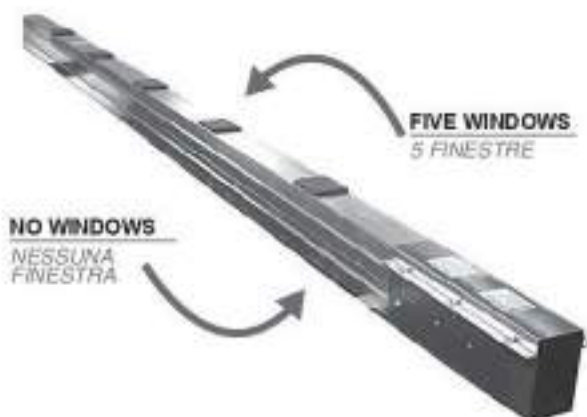

GENERAL DESCRIPTION DESCRIZIONE GENERALE

4 aluminium conductors aluminium housing 1 bolt joint easy to close, flanged joint housing 5 total big outlet windows to let plug in up to 250A tap-off.

4 conduttori in alluminio involucro in alluminio, giunzione monobullone. 5 finestre grandi (max 250A)

MAX TAP-OFF 250A



TASX 63A

FEED UNIT END CUP INCLUDED
CHIUSURA DI TESTATA INCLUSA

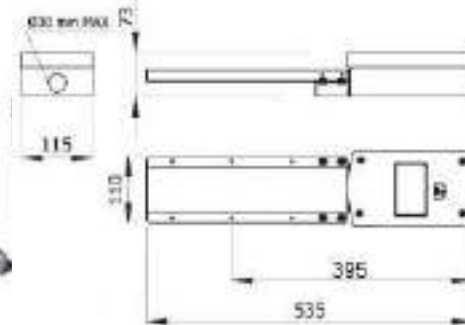

DETAIL OF DRILLING
INTERNAL BAR

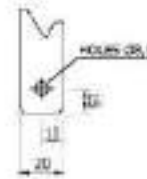

3P + N + PE
AMP 40 - 63 A
IP 41 - *IP 55
2,173
25 mm ²
4,500 Dm ³ VOLUME AFTER PACKING VOLUME IMBALLATO



TADX 63A

FEED UNIT END CUP INCLUDED
CHIUSURA DI TESTATA INCLUSA

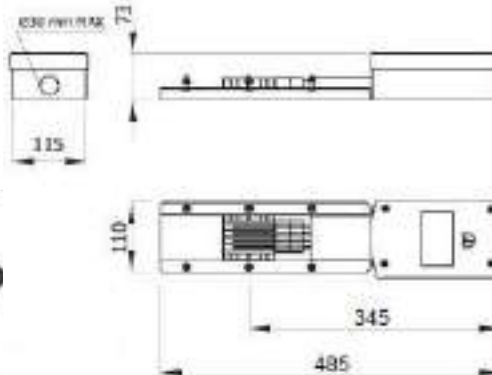

DETAIL OF DRILLING
INTERNAL BAR



3P + N + PE
AMP 40 - 63 A
IP 41 - *IP 55
2,350
25 mm ²
4,500 Dm ³ VOLUME AFTER PACKING VOLUME IMBALLATO



TASX 100A

FEED UNIT END CUP INCLUDED
CHIUSURA DI TESTATA INCLUSA

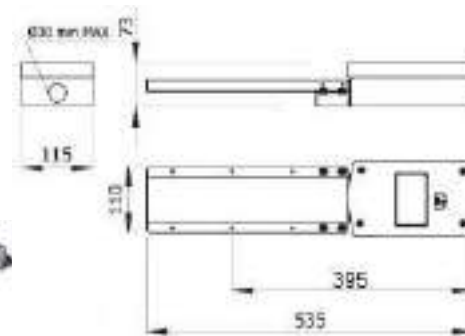

DETAIL OF DRILLING
INTERNAL BAR

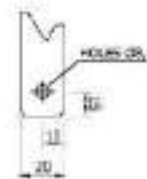

3P + N + PE
AMP 100 A
IP 41 - *IP 55
2,190
25 mm ²
4,500 Dm ³ VOLUME AFTER PACKING VOLUME IMBALLATO



TADX 100A

FEED UNIT END CUP INCLUDED
CHIUSURA DI TESTATA INCLUSA

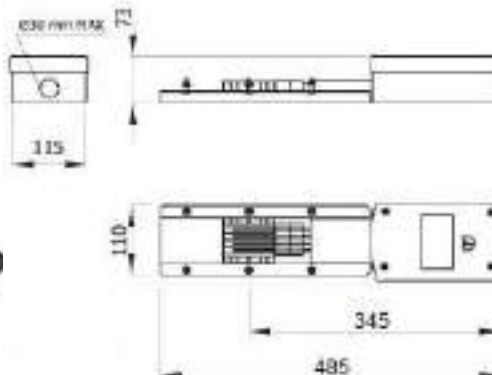

DETAIL OF DRILLING
INTERNAL BAR

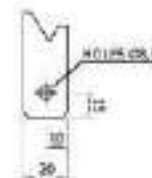

3P + N + PE
AMP 100 A
IP 41 - *IP 55
2,290
25 mm ²
4,500 Dm ³ VOLUME AFTER PACKING VOLUME IMBALLATO



TASX 160A

FEED UNIT END CUP INCLUDED
CHIUSURA DI TESTATA INCLUSA

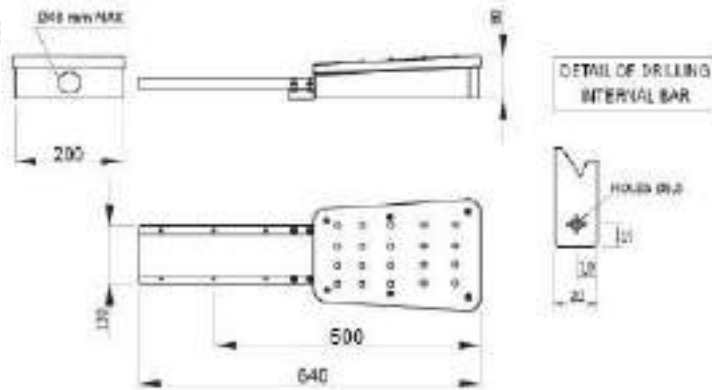

3P + N + PE
AMP 160 A
IP 41 - *IP 55
3,530
50 mm ²
12,00 Dm ³ VOLUME AFTER PACKING VOLUME IMBALLATO



TADX 160A

FEED UNIT END CUP INCLUDED
CHIUSURA DI TESTATA INCLUSA

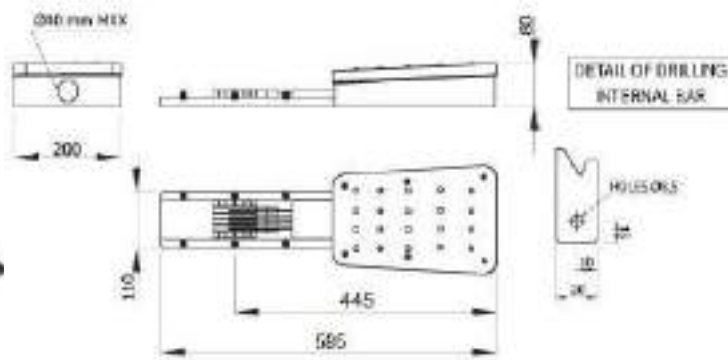

3P + N + PE
AMP 160 A
IP 41 - *IP 55
3,632
50 mm ²
12,00 Dm ³ VOLUME AFTER PACKING VOLUME IMBALLATO



TASX 250A

FEED UNIT END CUP INCLUDED
CHIUSURA DI TESTATA INCLUSA

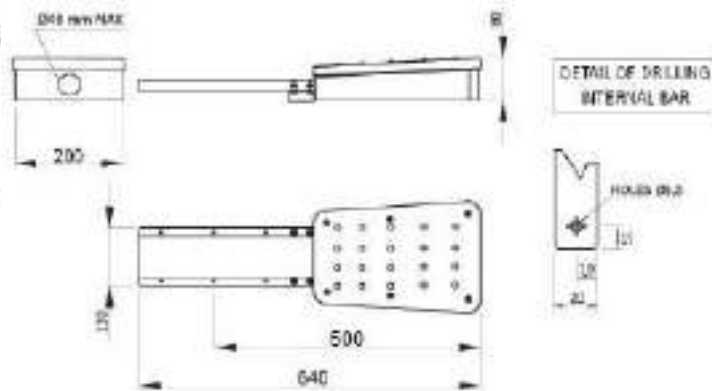

3P + N + PE
AMP 250 A
IP 41 - *IP 55
3,530
50 mm ²
12,00 Dm ³ VOLUME AFTER PACKING VOLUME IMBALLATO



TADX 250A

FEED UNIT END CUP INCLUDED
CHIUSURA DI TESTATA INCLUSA

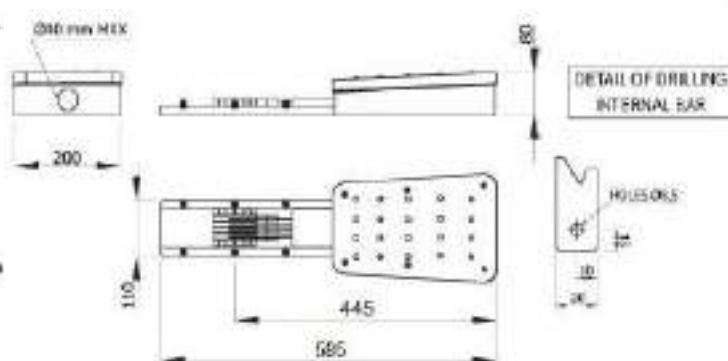

3P + N + PE
AMP 250 A
IP 41 - *IP 55
3,632
50 mm ²
12,00 Dm ³ VOLUME AFTER PACKING VOLUME IMBALLATO

NAXSO POWER

TASXBPG 1000ACC FEED UNIT END CUP INCLUDED
CHIUSURA DI TESTATA INCLUSA

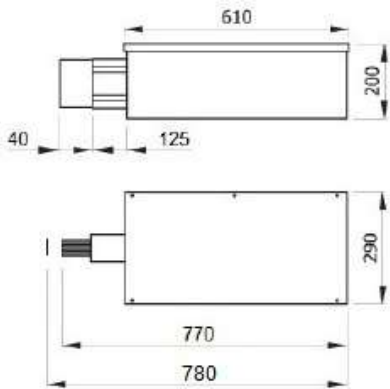

DETAIL OF DRILLING
INTERNAL BAR

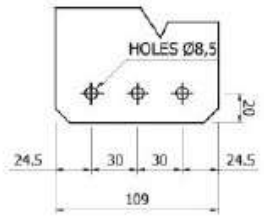

3P + N + PE
AMP 1000 A
IP 41 - *IP 55
20,000
67,20 Dm ³ VOLUME AFTER PACKING VOLUME IMBALLATO

TADXBPG 1000ACC FEED UNIT END CUP INCLUDED
CHIUSURA DI TESTATA INCLUSA

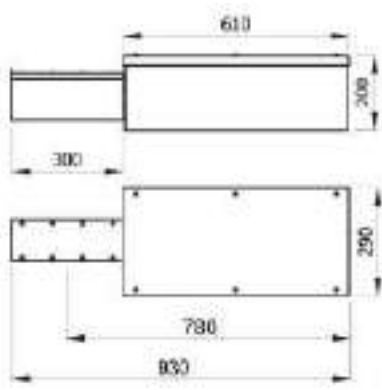

DETAIL OF DRILLING
INTERNAL BAR

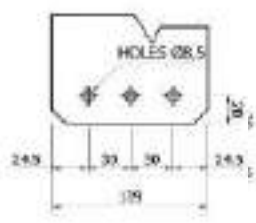

3P + N + PE
AMP 1000 A
IP 41 - *IP 55
21,000
67,20 Dm ³ VOLUME AFTER PACKING VOLUME IMBALLATO

FLX 100A FLEXIBLE UNIT

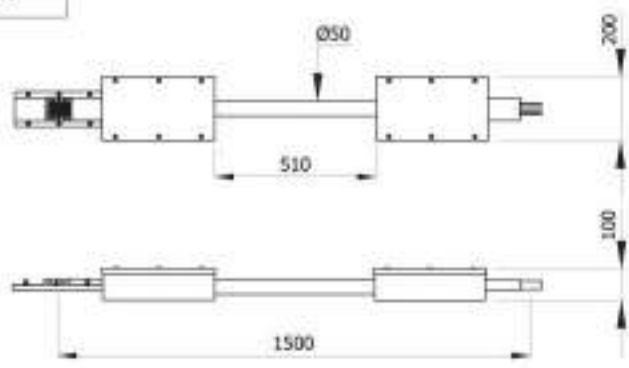

3P + N + PE
AMP 63 - 100 A
IP 41 - *IP 55
9,050
14,00 Dm ³ VOLUME AFTER PACKING VOLUME IMBALLATO
BP RANGE

FLX160A FLEXIBLE UNIT

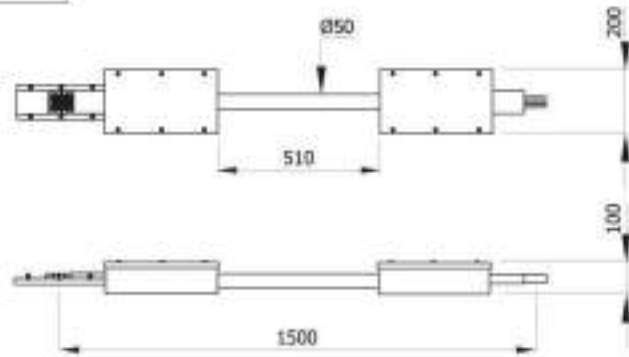

3P + N + PE
AMP 160 A
IP 41 - *IP 55
10,000
14,00 Dm ³ VOLUME AFTER PACKING VOLUME IMBALLATO
BP RANGE



FLX250A

FLEXIBLE UNIT

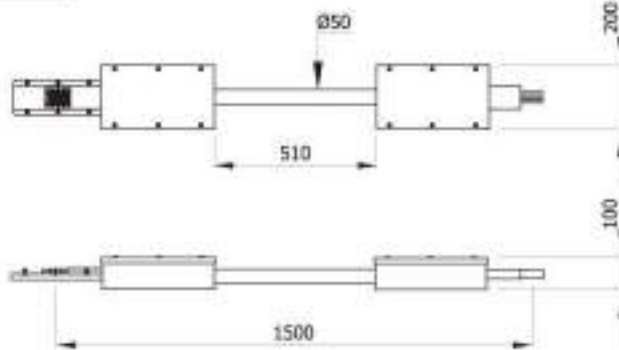

3P + N + PE
AMP 250 A
IP 41 - *IP 55
10,000
14,00 Dm ³ VOLUME AFTER PACKING VOLUME IMBALLATO
BP RANGE



ACPWP100

CENTER FEED

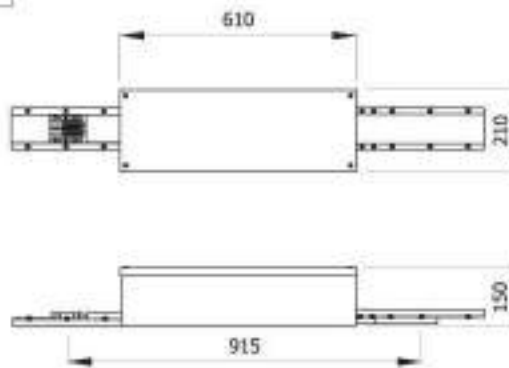

3P + N + PE
AMP 40 - 63 - 100 A
IP 41 - *IP 55
9,00
25 mm ²
40,00 Dm ³ VOLUME AFTER PACKING VOLUME IMBALLATO



ACPWGBP160

CENTER FEED

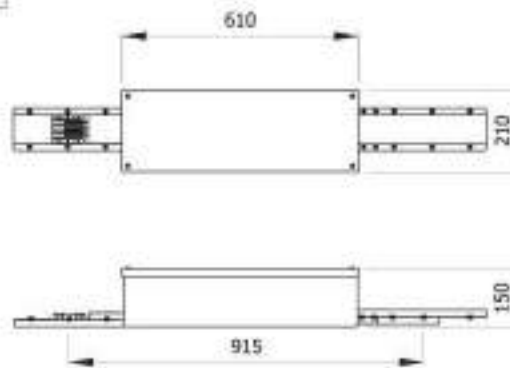

3P + N + PE
AMP 160 A
IP 41 - *IP 55
12,50
50 mm ²
40,00 Dm ³ VOLUME AFTER PACKING VOLUME IMBALLATO



ACPWGBP250

CENTER FEED

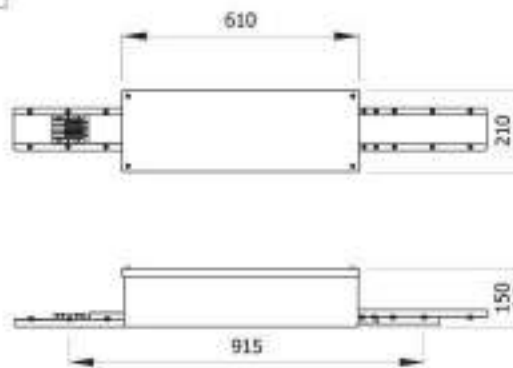

3P + N + PE
AMP 250 A
IP 41 - *IP 55
12,50
50 mm ²
40,00 Dm ³ VOLUME AFTER PACKING VOLUME IMBALLATO

FLXBPG 250ACC FLEXIBLE UNIT

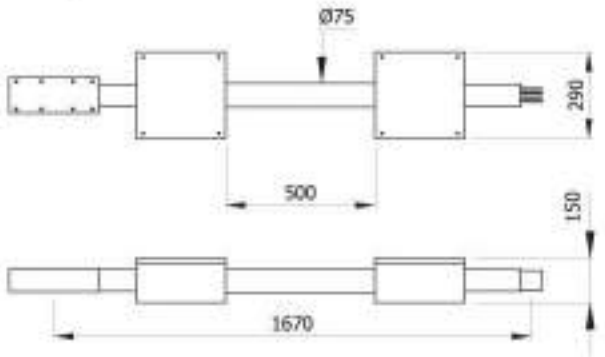

3P + N + PE
AMP 250 A
IP 41 - *IP 55
22,700
13,90 Dm ³ VOLUME AFTER PACKING VOLUME IMBALLATO
BPG RANGE

FLXBPG 400ACC FLEXIBLE UNIT

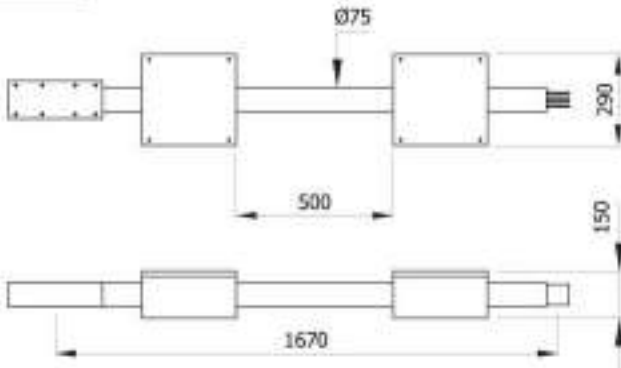

3P + N + PE
AMP 400 A
IP 41 - *IP 55
25,644
13,90 Dm ³ VOLUME AFTER PACKING VOLUME IMBALLATO
BPG RANGE

FLXBPG 630ACC FLEXIBLE UNIT

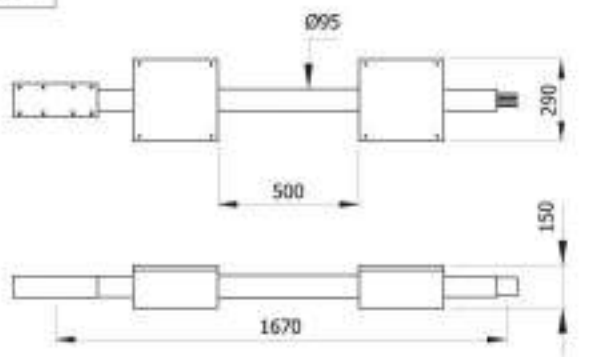

3P + N + PE
AMP 500 - 630 A
IP 41 - *IP 55
30,000
13,90 Dm ³ VOLUME AFTER PACKING VOLUME IMBALLATO

FLXBPG 800ACC FLEXIBLE UNIT

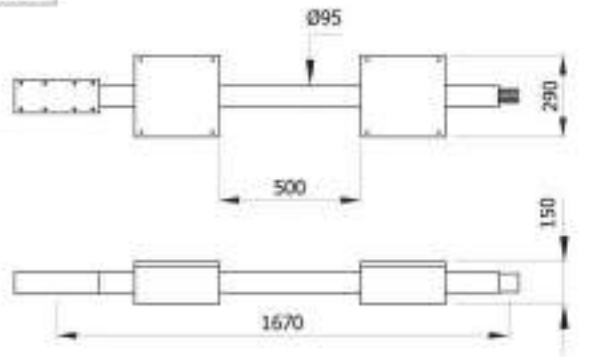

3P + N + PE
AMP 800 A
IP 41 - *IP 55
36,000
13,90 Dm ³ VOLUME AFTER PACKING VOLUME IMBALLATO



ACPW BPG250ACC

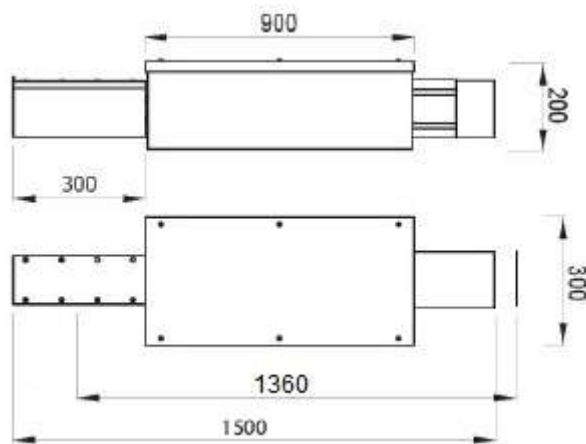

3P + N + PE
AMP 250 A
IP 41 - *IP 55
3,200
40,30 Dm ³ VOLUME AFTER PACKING VOLUME IMBALLATO



ACPW BPG400ACC

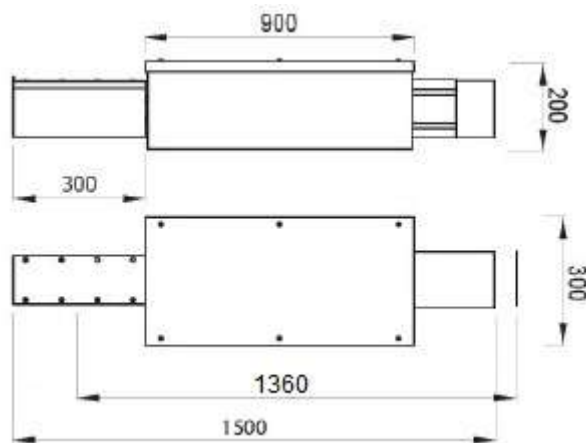

3P + N + PE
AMP 400 A
IP 41 - *IP 55
14,070
40,30 Dm ³ VOLUME AFTER PACKING VOLUME IMBALLATO



ACPW BPG630ACC

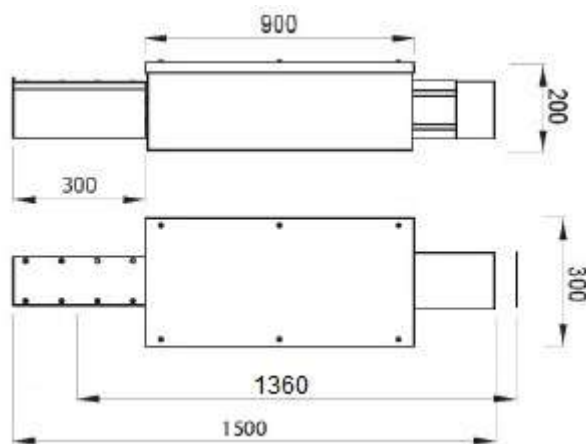

3P + N + PE
AMP 630 A
IP 41 - *IP 55
14,300
40,30 Dm ³ VOLUME AFTER PACKING VOLUME IMBALLATO

ACPW BPG800ACC

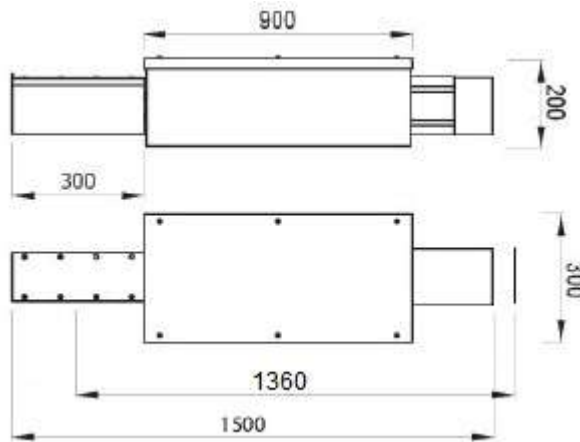

3P + N + PE
AMP 800 A
IP 41 - *IP 55
9,000
40,00 Dm ³ VOLUME AFTER PACKING VOLUME IMBALLATO

ACPW BPG1000ACC

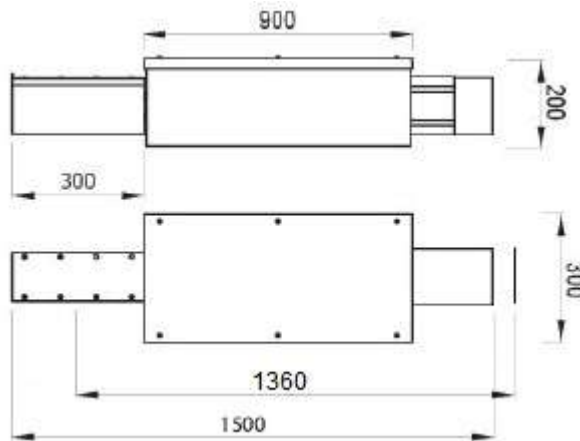

3P + N + PE
AMP 1000 A
IP 41 - *IP 55
12,500
40,00 Dm ³ VOLUME AFTER PACKING VOLUME IMBALLATO

QBPG250ACC

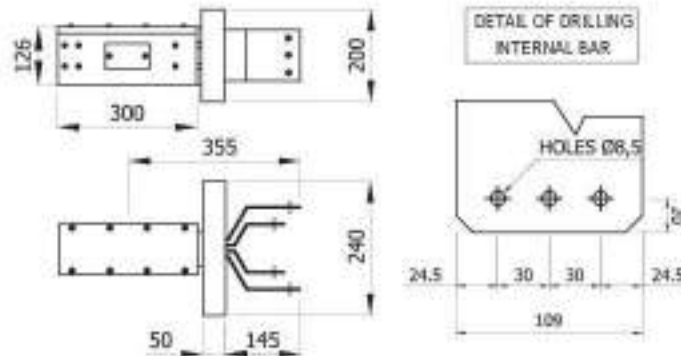

3P + N + PE
AMP 250 A
IP 41 - *IP 55
8,000
6,000 Dm ³ VOLUME AFTER PACKING VOLUME IMBALLATO

QBPG400ACC

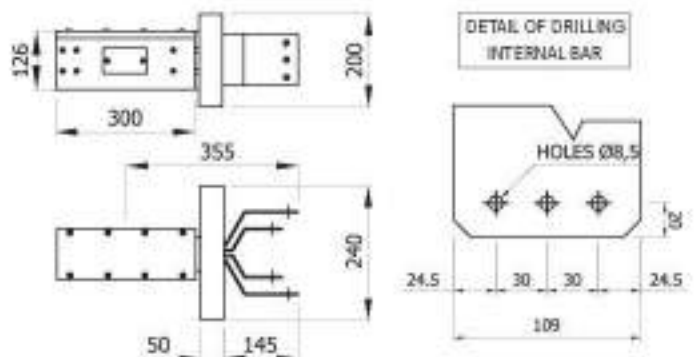

3P + N + PE
AMP 400 A
IP 41 - *IP 55
8,000
6,000 Dm ³ VOLUME AFTER PACKING VOLUME IMBALLATO



QBPG630ACC

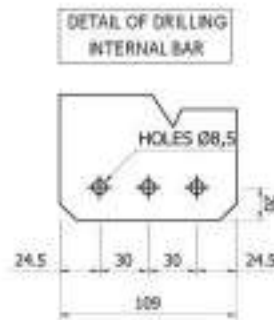
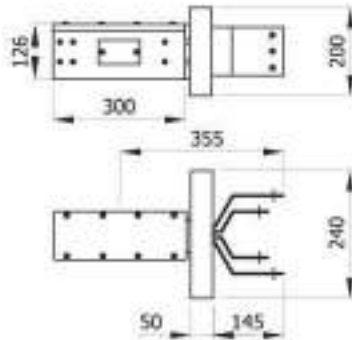

3P + N + PE
AMP 630 A
IP 41 - *IP 55
6,650
6,000 Dm ³ VOLUME AFTER PACKING VOLUME IMBALLATO



QBPG800ACC

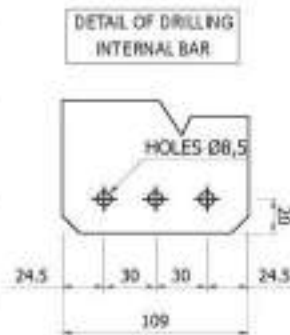
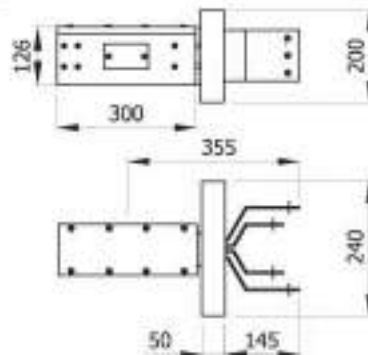

3P + N + PE
AMP 800 A
IP 41 - *IP 55
10,000
12,00 Dm ³ VOLUME AFTER PACKING VOLUME IMBALLATO



QBPG1000ACC

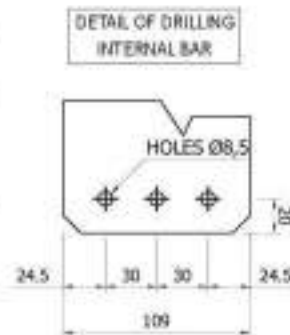
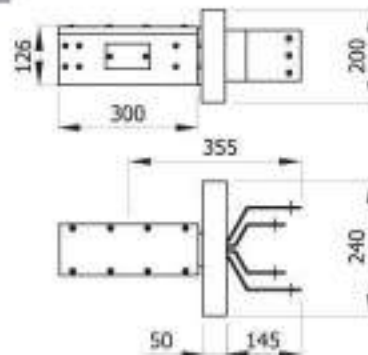

3P + N + PE
AMP 1000 A
IP 41 - *IP 55
12,000
12,00 Dm ³ VOLUME AFTER PACKING VOLUME IMBALLATO



CSBPG 250ACC

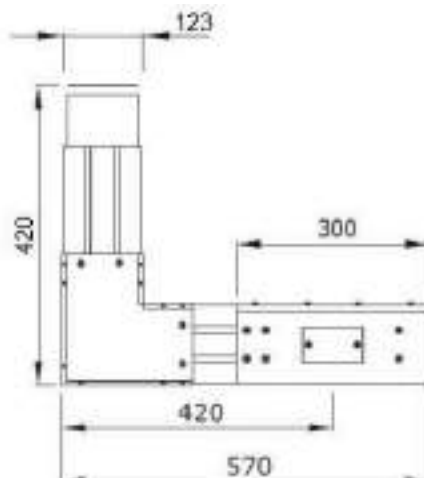

3P + N + PE
AMP 250 A
IP 41 - *IP 55
6,000
30,00 Dm ³ VOLUME AFTER PACKING VOLUME IMBALLATO

 **CSBPG 400ACC**

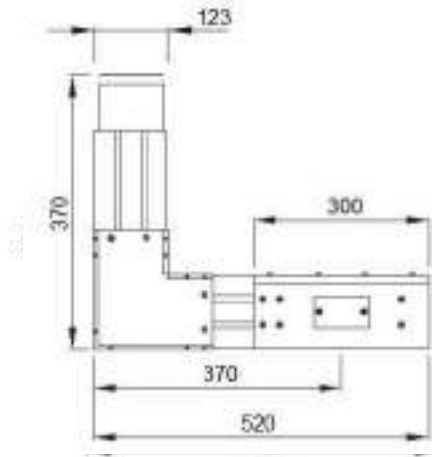

3P + N + PE
AMP 400 A
IP 41 - *IP 55
 9,000
 30,00 Dm ³ VOLUME AFTER PACKING VOLUME IMBALLATO

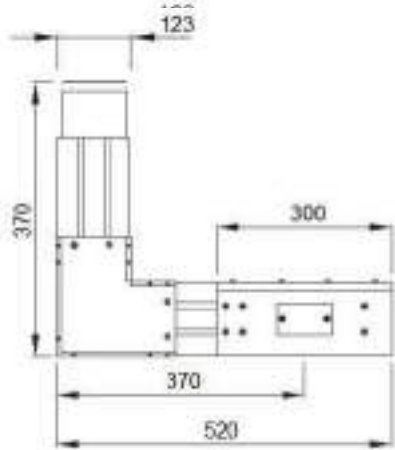

 **CSBPG 630ACC**



3P + N + PE
AMP 630 A
IP 41 - *IP 55
 9,503
 30,00 Dm ³ VOLUME AFTER PACKING VOLUME IMBALLATO

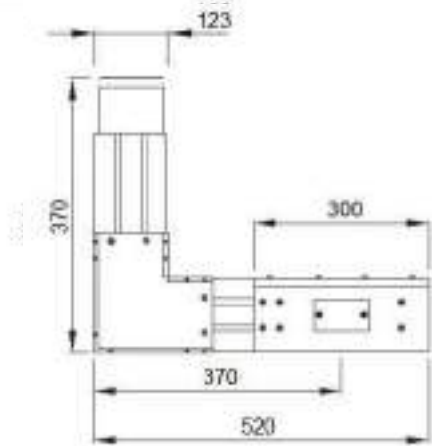

 **CSBPG 800ACC**

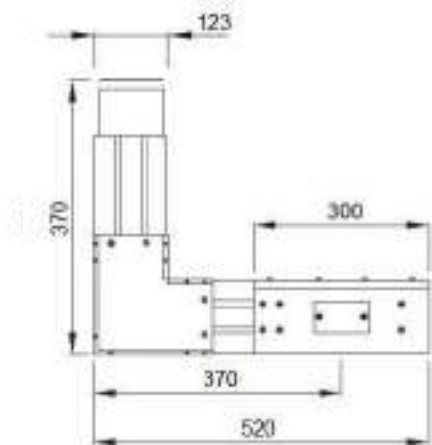

3P + N + PE
AMP 800 A
IP 41 - *IP 55
 10,530
 30,00 Dm ³ VOLUME AFTER PACKING VOLUME IMBALLATO

 **CSBPG 1000ACC**



3P + N + PE
AMP 1000 A
IP 41 - *IP 55
 13,000
 30,00 Dm ³ VOLUME AFTER PACKING VOLUME IMBALLATO



CPBPG 250ACC

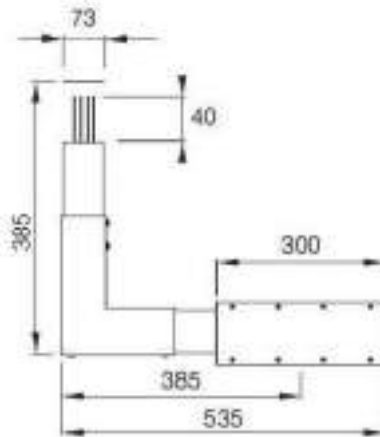

3P + N + PE
AMP 250 A
IP 41 - *IP 55
8,092
30,00 Dm ³ VOLUME AFTER PACKING VOLUME IMBALLATO



CPBPG 400ACC

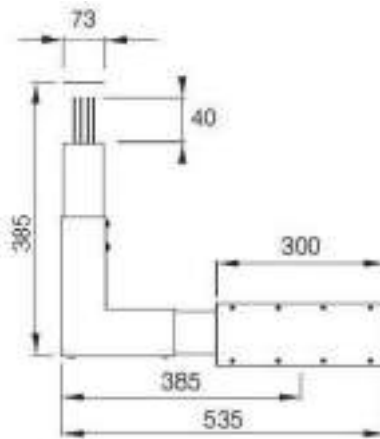

3P + N + PE
AMP 400 A
IP 41 - *IP 55
8,461
30,00 Dm ³ VOLUME AFTER PACKING VOLUME IMBALLATO



CPBPG 630ACC

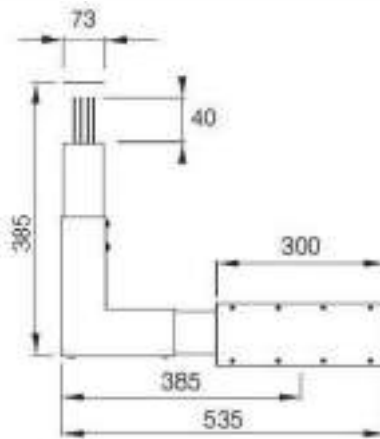

3P + N + PE
AMP 630 A
IP 41 - *IP 55
9,555
30,00 Dm ³ VOLUME AFTER PACKING VOLUME IMBALLATO



CPBPG 800ACC

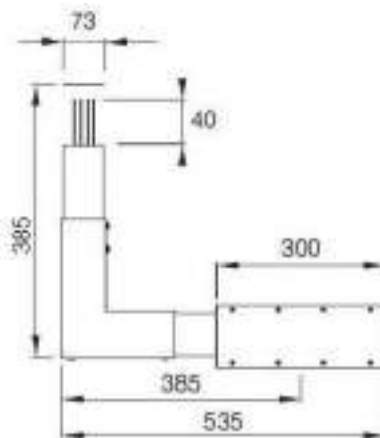

3P + N + PE
AMP 800 A
IP 41 - *IP 55
10,320
30,00 Dm ³ VOLUME AFTER PACKING VOLUME IMBALLATO

 CPBPG 1000ACC

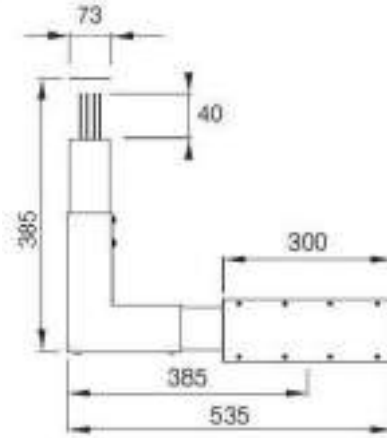

3P + N + PE
AMP 1000 A
IP 41 - *IP 55
 10,320
 30,00 Dm ³ VOLUME AFTER PACKING VOLUME IMBALLATO

 IP55BRP



 0,010
 0,50 Dm ³ VOLUME AFTER PACKING VOLUME IMBALLATO
IP55 BP

 IP55OT



 0,037
 0,50 Dm ³ VOLUME AFTER PACKING VOLUME IMBALLATO
IP55 BP

 IP55BRG



 0,037
 0,50 Dm ³ VOLUME AFTER PACKING VOLUME IMBALLATO
IP55 BPG

 IP55OT G



 0,037
 0,50 Dm ³ VOLUME AFTER PACKING VOLUME IMBALLATO
IP55 BPG

INTERLOCK MECHANISM lets the tap off in position on the busbar opening the cover lid the internal parts are out of tension because the interlock is depending on the covers blades that cut the tension between terminal and circuit breaker or fuse holder no internal parts when the cover is open are under tension. Open the cover no tension into the tap off.

SUPERCAT STANDARD (SUPERCAT...D / SUPERCAT...F)

- 1- TAP-OFF CONNECTED
- 2- CIRCUIT TO FEED MACHINE OPEN
- 3- OPEN THE TAP-OFF WITHOUT REMOVING (INTERLOCK)

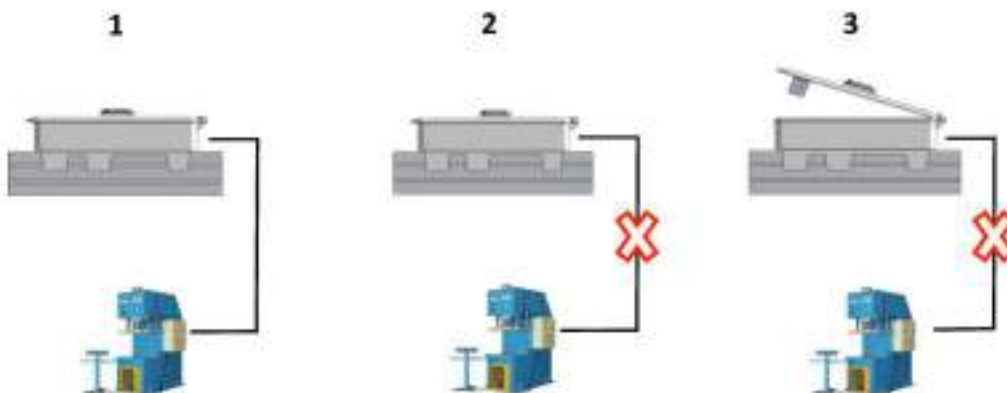

NO INTERLOCK MECHANISM MEANS that to open the cover lid the operator must remove the tap off from the busbar, only after this the cover can be removed because the screws to open the cover are facing the busbar remove the tap off and after this can remove the cover and open the tap off

SUPERCAT SEMPLIFIED (SUPERCAT...DS / SUPERCAT...FS)

- 1- TAP-OFF CONNECTED
- 2- CIRCUIT TO FEED MACHINE OPEN
- 3- TAP-OFF IS REMOVED FROM BUSBAR (NOT OPEN COVER BEFORE) NOT INTERLOCK
- 4- OPEN THE COVER

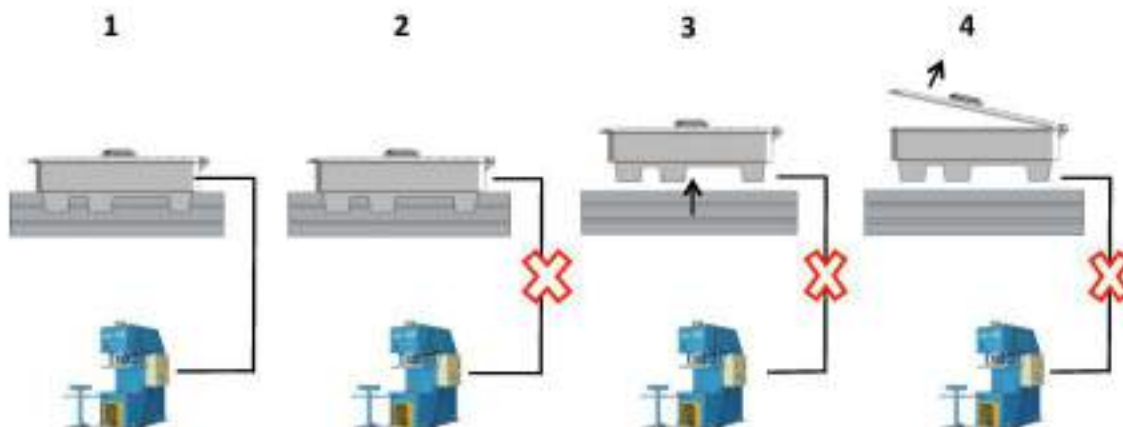

 **CAT**

TAB. B POLYPROPYLENE



GENERAL DESCRIPTION DESCRIZIONE GENERALE

Cat is the small tap off box 3P+PE for all the ranges BP and BPG plastic made of polypropylene and internal contacts in copper can be prepared for direct connection or for use fuse holders or for circuit breakers installed on DIN rails ratings can be 32 A. The safety is assured as to open the lid this tap off shall be uninstalled from the busbar mechanically.

Spina di ridotte dimensioni per impieghi leggeri da 32 A 3P+T. Può avere connessioni dirette oppure può ospitare interruttori magnetotermici e portafusibili installabili sulla guida DIN contenuta internamente. La sicurezza è data dalla impossibilità di rimuovere il coperchio a spina installata.

 **SUPERCAT**

TAB. B POLYPROPYLENE



Supercat is a flexible tap off multipurpose for a wide range of installations. This tap off can contain circuit breakers or fuse holders or a number of electronic parts. The ratings can be from 50 to 100 A and the security is assured by the interlock mechanism as opening the lid, the current is off even into the internal connections. A lot of special tap offs can be prepared on request. Some pictures at the end of this part of the catalogue give an idea of the different tap off, we can make compatible with all ranges BP-BPG

Supercat è una spina compatibile con la interserie Power di grande flessibilità in quanto può ospitare interruttori su guida DIN e portafusibili di potenze da 50 a 100 A ed anche una serie di svariati allestimenti a richiesta con prese e altri elementi di elettronica e di comando. Tutte queste diverse realizzazioni sono su richiesta e sono sintetizzate per esempio a fondo delle illustrazioni della serie Power. La sicurezza è garantita dal fatto che a coperchio aperto la spina non ha parti accessibili attive all'interno.

 **STAR**

TAB. B POLYPROPYLENE



Star is the biggest plastic tap off box with all the specifications as per Supercat and ratings from 50 to 160 A. As per Supercat this tap off can be requested on demand with special sets of plugs and other electrical or electronic parts. See pictures at the end of this power part.

Spina di grandi dimensioni in materiale plastico. Potenze da 50 a 160 A ed accoglie tutti i portafusibili e gli interruttori su guida DIN relativi alla portata. Può anche essere allestita con elementi speciali a richiesta come prese CEE come da figura a fine settore Power. Il meccanismo sul coperchio di interruzione della corrente interna e coperchio aperto ne consente l'operatività in totale sicurezza.

 **STAR DM**

METAL



Metal Star is the big metal tap off box with all the specifications as per Star plastic and ratings from 50 to 250 A. As per Star plastic this tap off can be requested on demand with special sets of plugs and other electrical or electronic part. See pictures at the end of this power part. The internal circuits are protected for security reasons by a transparent plastic strong barrier. On demand can be installed a proper handle circuit breaker to interrupt current when the rotation hand is on open position to let open the lid with no current inside

Spina di grandi dimensioni in metallo, capacità da 50 a 250 A, accoglie tutti i portafusibili e gli interruttori su guida di relativi alla portata. Accoglie apparecchiature come interruttori scolari e portafusibili di grandi dimensioni sezionabili. Può essere allestita con elementi a richiesta come prese CEE come da figura a fine settore Power. Può essere dotata a richiesta di interruttore rotativo di protezione ed interruzione delle parti elettriche interne attive quando si apre il coperchio, mentre di serie la protezione delle parti in tensione è data da una parete di sicurezza in plastica trasparente.

CAT 32D TAP OFF

WARNING: This body is very small
ATTENZIONE: questa spina ha dimensioni molto ridotte incompatibili con cavi rigidi



DIN RAIL (inside)

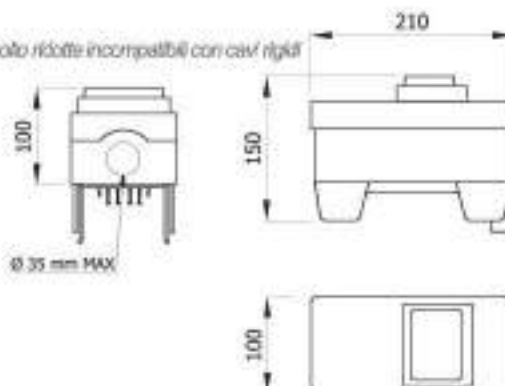

3P + N + PE
AMP 32 A
IP 41 - *IP 55
0,950
10 mm ² TERMINAL BLOCK MORSETTIERA
9,706 Dm ³ VOLUME AFTER PACKING VOLUME IMBALLATO
4 MODULS
DIN RAIL

CAT 32DC TAP OFF

WARNING: This body is very small
ATTENZIONE: questa spina ha dimensioni molto ridotte incompatibili con cavi rigidi



DIN RAIL (inside)

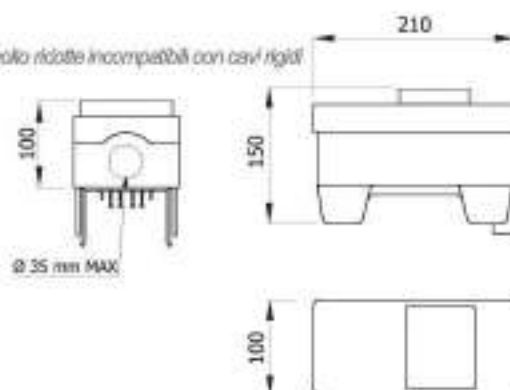

3P + N + PE
AMP 32 A
IP 41 - *IP 55
0,950
10 mm ² TERMINAL BLOCK MORSETTIERA
9,706 Dm ³ VOLUME AFTER PACKING VOLUME IMBALLATO
4 MODULS
DIN RAIL

CAT 32DT TAP OFF

WARNING: This body is very small
ATTENZIONE: questa spina ha dimensioni molto ridotte incompatibili con cavi rigidi



DIN RAIL (inside)

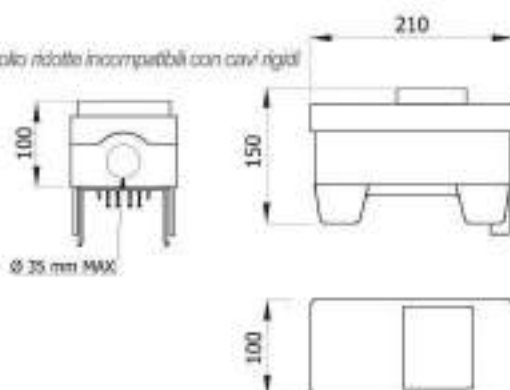

3P + N + PE
AMP 32 A
IP 41 - *IP 55
0,950
10 mm ² TERMINAL BLOCK MORSETTIERA
9,706 Dm ³ VOLUME AFTER PACKING VOLUME IMBALLATO
4 MODULS
DIN RAIL

CAT 32F TAP OFF

WARNING: This body is very small
ATTENZIONE: questa spina ha dimensioni molto ridotte incompatibili con cavi rigidi



DIN RAIL (inside)

FUSE HOLDER

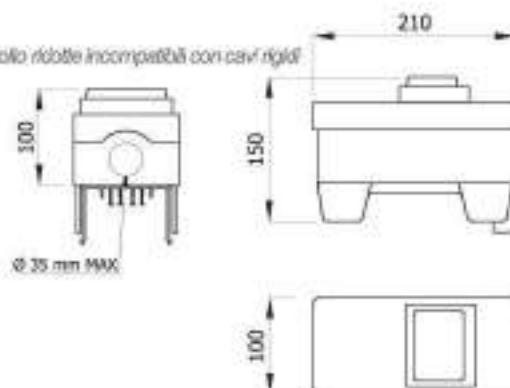

3P + N + PE
AMP 32 A
IP 41 - *IP 55
1,000
10 mm ² TERMINAL BLOCK MORSETTIERA
9,706 Dm ³ VOLUME AFTER PACKING VOLUME IMBALLATO
10 x 38
4 MODULS
DIN RAIL

SUPERCAT 50D TAP OFF

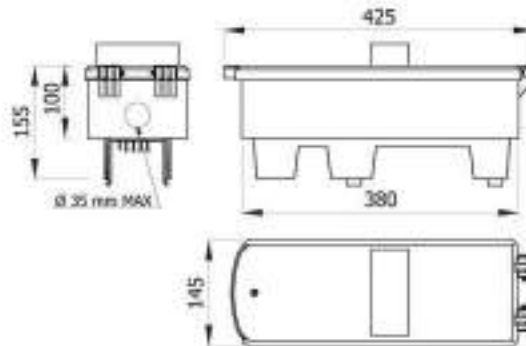

3P + N + PE
AMP 50 A
IP 41 - *IP 55
2,300
16 mm ² TERMINAL BLOCK MORSETTERIA
16,00 Dm ³ VOLUME AFTER PACKING VOLUME IMBALLATO
4 MODULS
DIN RAIL

SUPERCAT 50DC TAP OFF

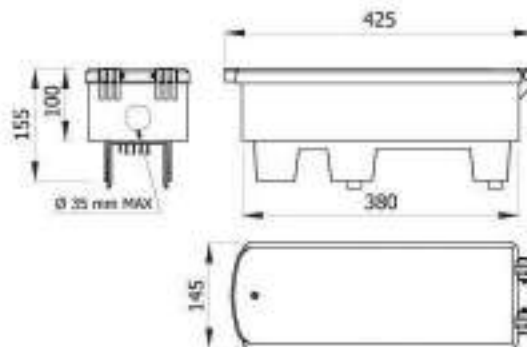

3P + N + PE
AMP 50 A
IP 41 - *IP 55
2,300
16 mm ² TERMINAL BLOCK MORSETTERIA
16,00 Dm ³ VOLUME AFTER PACKING VOLUME IMBALLATO
4 MODULS
DIN RAIL

SUPERCAT 50DT TAP OFF

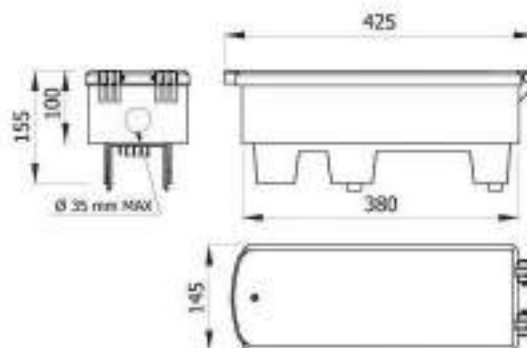

3P + N + PE
AMP 50 A
IP 41 - *IP 55
2,300
16 mm ² TERMINAL BLOCK MORSETTERIA
16,00 Dm ³ VOLUME AFTER PACKING VOLUME IMBALLATO
4 MODULS
DIN RAIL

SUPERCAT 50F TAP OFF

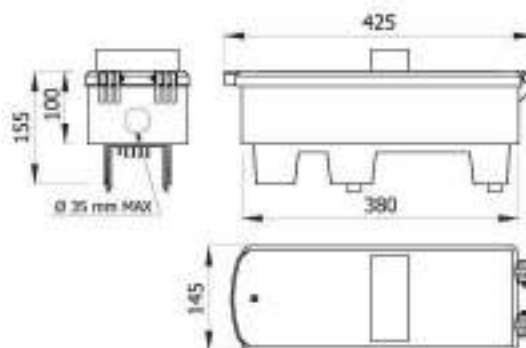
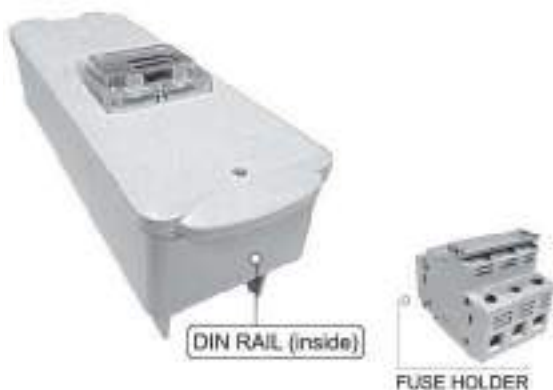

3P + N + PE
AMP 50 A
IP 41 - *IP 55
2,700
10 mm ² Max 16 mm ² TERMINAL BLOCK MORSETTIERA
16,00 Dm ³ VOLUME AFTER PACKING VOLUME IMBALLATO
14 x 51
4 MODULS
DIN RAIL

SUPERCAT 100D TAP OFF

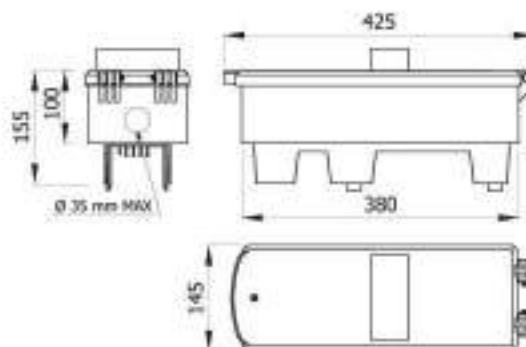

3P + N + PE
AMP 100 A
IP 41 - *IP 55
2,300
35 mm ² TERMINAL BLOCK MORSETTIERA
16,00 Dm ³ VOLUME AFTER PACKING VOLUME IMBALLATO
14 x 51
4 MODULS
DIN RAIL

SUPERCAT 100DC TAP OFF

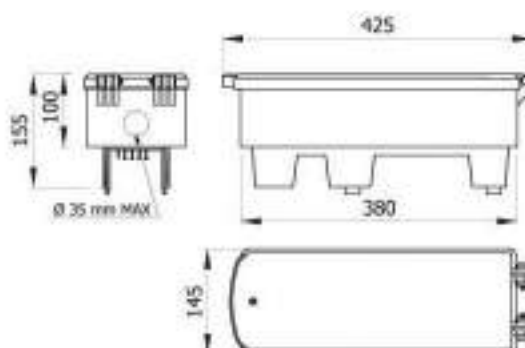

3P + N + PE
AMP 100 A
IP 41 - *IP 55
2,300
35 mm ² TERMINAL BLOCK MORSETTIERA
16,00 Dm ³ VOLUME AFTER PACKING VOLUME IMBALLATO
14 x 51
4 MODULS
DIN RAIL

 **SUPERCAT 100DT** TAP OFF

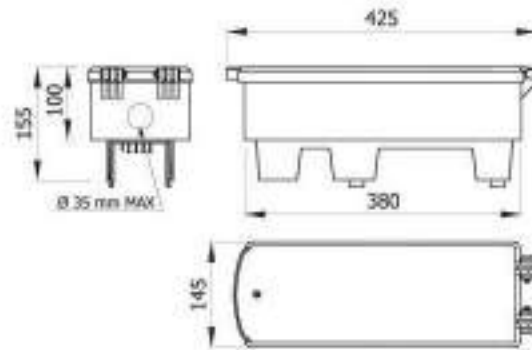

3P + N + PE
AMP 100 A
IP 41 - *IP 55
 2,300
 35 mm ² TERMINAL BLOCK MORSETTIERA
 16,00 Dm ³ VOLUME AFTER PACKING VOLUME IMBALLATO
4 MODULS
 DIN RAIL

 **SUPERCAT 100F** TAP OFF

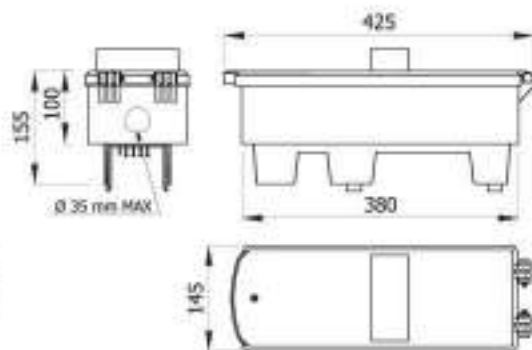

3P + N + PE
AMP 100 A
IP 41 - *IP 55
 2,700
 35 mm ² TERMINAL BLOCK MORSETTIERA
 16,00 Dm ³ VOLUME AFTER PACKING VOLUME IMBALLATO
 22 x 58
4 MODULS
 DIN RAIL



STAR 100 - 125D

TAP OFF



DIN RAIL (inside)



TERMINAL

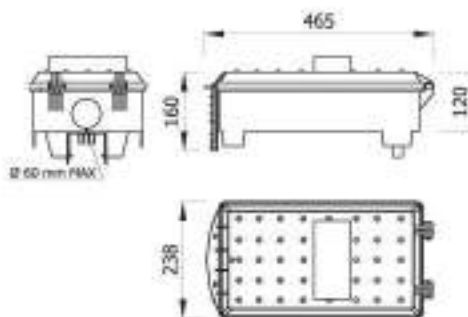

Ø 60 mm MAX.

3P + N + PE
AMP 100 - 125 A
IP 41 - *IP 55
3,700
35 mm² TERMINAL BLOCK MORSETTIERA
20,40 Dm³ VOLUME AFTER PACKING VOLUME IMBALLATO
8 MODULS
DIN RAIL



STAR 100F

TAP OFF



TERMINAL



FUSE HOLDER

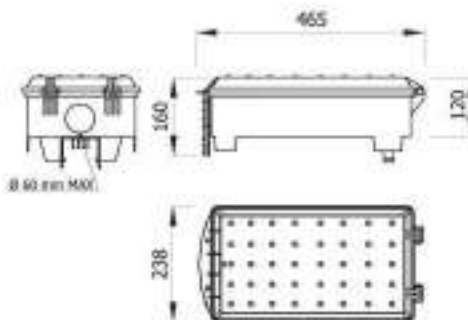

Ø 60 mm MAX.

3P + N + PE
AMP 100 A
IP 41 - *IP 55
3,246
35 mm² TERMINAL BLOCK MORSETTIERA
20,40 Dm³ VOLUME AFTER PACKING VOLUME IMBALLATO
22 x 58
DIN RAIL



STAR 125F

TAP OFF



TERMINAL



FUSE HOLDER

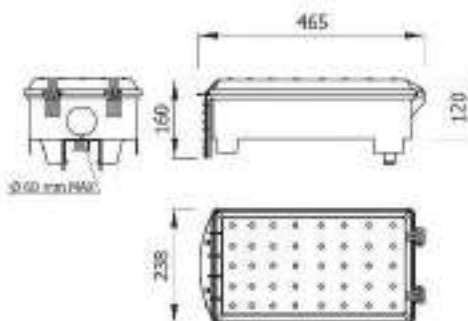

Ø 60 mm MAX.

3P + N + PE
AMP 125A
IP 41 - *IP 55
3,200
35 mm² TERMINAL BLOCK MORSETTIERA
16,00 Dm³ VOLUME AFTER PACKING VOLUME IMBALLATO
NH00

STAR 160F TAP OFF

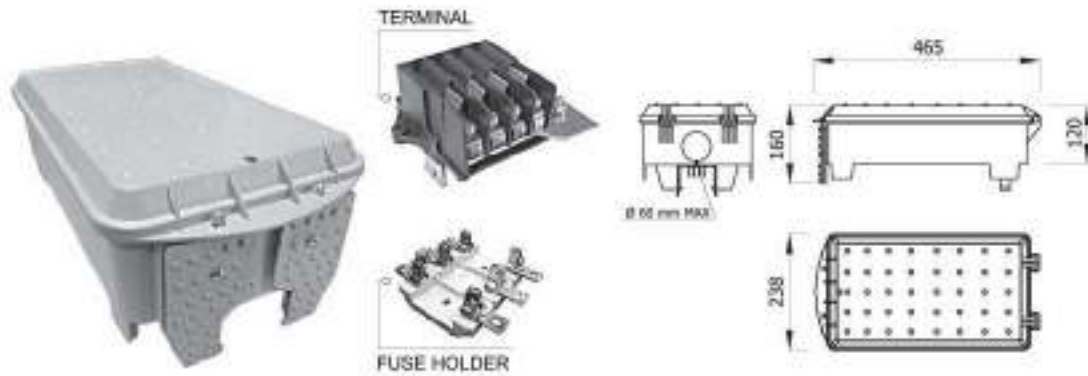

3P + N + PE
AMP 160 A
IP 41 - *IP 55
3,200
2,5 mm² Max 25 mm² TERMINAL BLOCK MORSETTIERA
20,40 Dm³ VOLUME AFTER PACKING VOLUME IMBALLATO
NH00

STAR 160DM TAP OFF

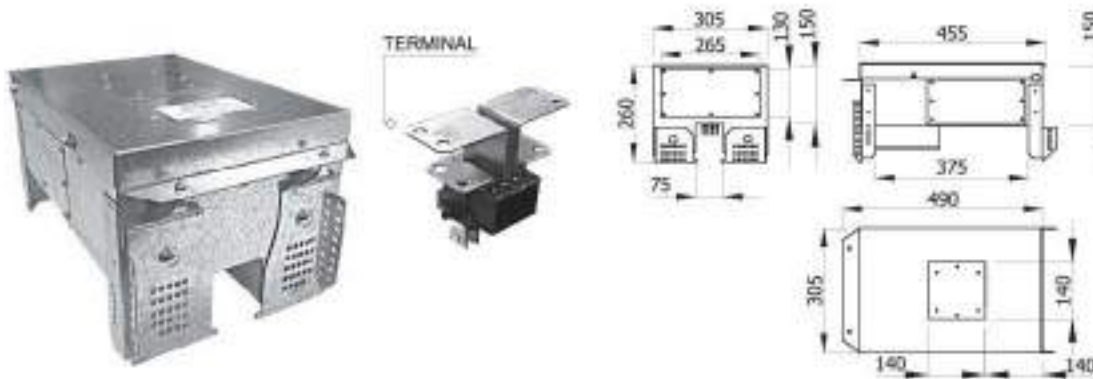

3P + N + PE
AMP 160 A
IP 41 - *IP 55
14,070
90 mm² TERMINAL BLOCK MORSETTIERA
40,30 Dm³ VOLUME AFTER PACKING VOLUME IMBALLATO

STAR 160DMF TAP OFF

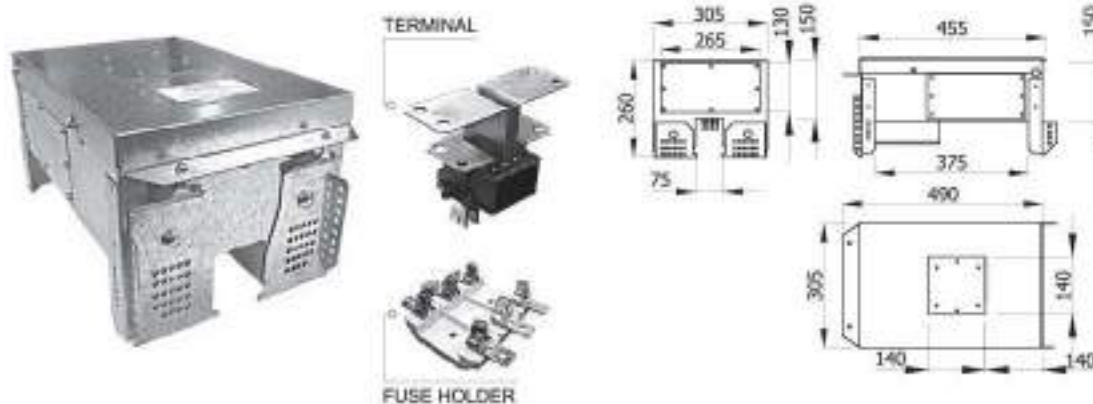

3P + N + PE
AMP 160 A
IP 41 - *IP 55
14,300
90 mm² TERMINAL BLOCK MORSETTIERA
40,30 Dm³ VOLUME AFTER PACKING VOLUME IMBALLATO
NH00



STAR 250DM

TAP OFF



TERMINAL

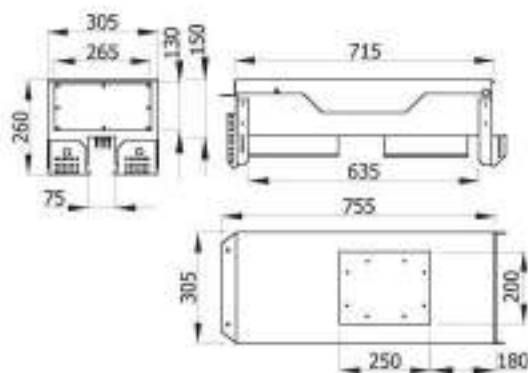

3P + N + PE
AMP 250 A
IP 41 - *IP 55
16,500
90 mm ² TERMINAL BLOCK MORSETTIERA
40,30 Dm ³ VOLUME AFTER PACKING VOLUME INSTALLATO



STAR 250DMF

TAP OFF



TERMINAL



FUSE HOLDER

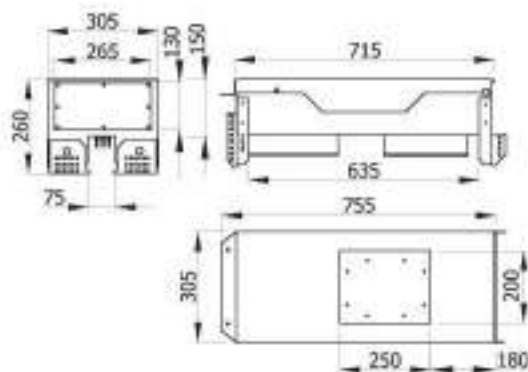

3P + N + PE
AMP 250 A
IP 41 - *IP 55
20,100
90 mm ² TERMINAL BLOCK MORSETTIERA
40,30 Dm ³ VOLUME AFTER PACKING VOLUME INSTALLATO
NH01

BRACKETS NAXSOPOWER

BP

STS

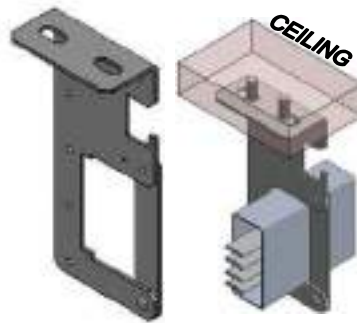
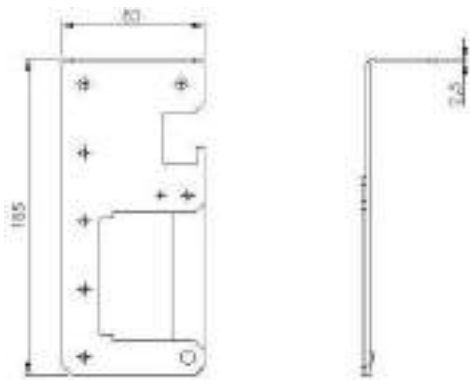

BRACKETS FOR BP RANGE FOR CEILING SUSPENSION

METAL LID TO FIX THE BUSBAR

THE LITTLE AREA ON TOP OF THE BUSBAR ROOM IN TO LET A LASTIC PIPE OR A PLASTICA CABLE TRAY FOR CABLES THE DIMENSION IN 18 MM X 18 MM

STP

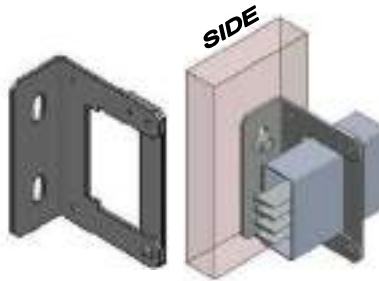
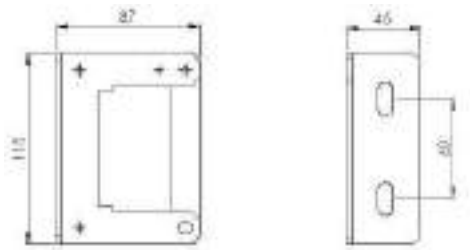

WALL BRACKET FOR BP RANGE

THIS BRACKET MAY EVEN BE FIXED TO FLOOR TO LET A FLOOR INSTALLATION

STSNL

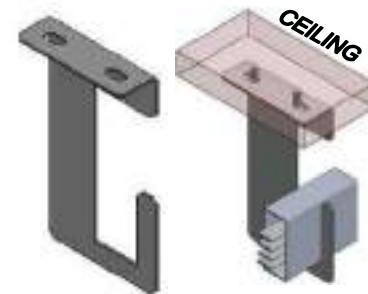
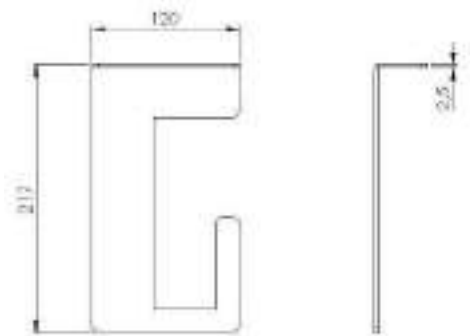

CEILING BRACKETS WITHOUT LID SIMPLE INSTALLATION WHERE THE BP RANGE CAN BE SLIDED AND THAT SITTED DOWN WITHOUT THE RISK OF EXITING DUE TO THE VERY STRAIGHT DIMENSION OF THE ENTRANCE SO THAT ONLY A STRICT INSERTION MAY THE BUSBAR ENTER IN THE PLACE

STPNL

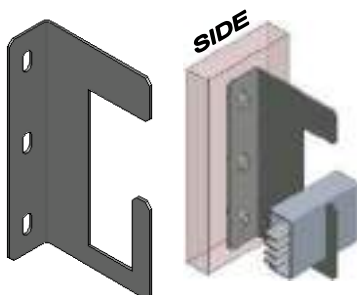
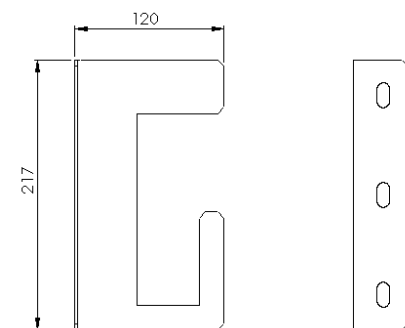

WALL BRACKET WITHOUT LID SIMPLE INSTALLATION WHERE BP RANGE CAN BE SLIDED AND THAT SITTED DOWN WITHOUT THE RISK OF EXITING DUE TO THE VERY STRAIGHT DIMENSION OF THE ENTRANCE SO THAT ONLY A STRICT INSERTION MAY THE BUSBAR ENTER IN THE PLACE

STSL

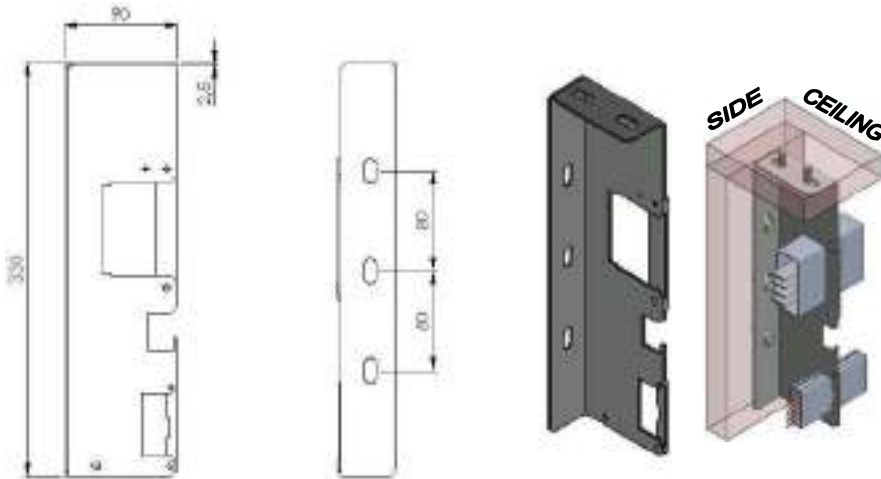

CEILING OR WALL BRACKET TO LET DOUBLE INSTALLATION BP RANGE AND LIGHTING RANGE

BUSBAR WITH AN ADDITIONAL AREA FOR CABLE TRAY PLASTIC MADE OR PIPE CABLE

THE AREA FOR PIPE OR CABLE TRAY IS 18 MM X 18 MM

STPP

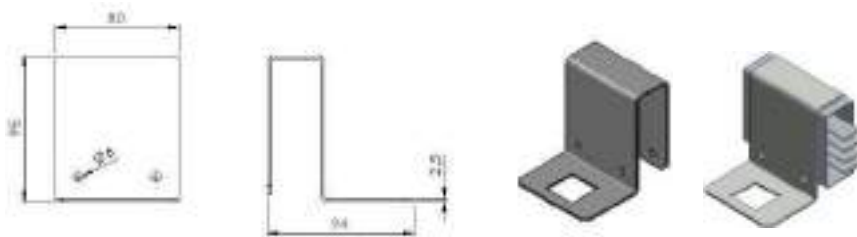

BRACKET TO LET A CABLE OUT OF THE TAP OFF BE FIXED IN A VERTICAL RUN WITHOUT WEIGHTING ON THE TAP OFF

STK



SIMPLE BP RANGE BRACKET TO BE FIXED TO EXISTING PART LIKE PILLARS, STRUCTURAL RUNS OR CABLE TRAYS

BPG

STPG

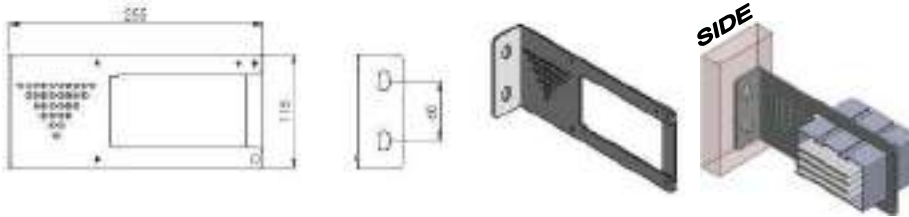

WALL INSTALLATION BRACKET FOR BPG RANGE ABLE TO FIX THE BUSBAR AT A DISTANCE OF 100 MM FROM THE WALL

STSG



CEILING BRACKET TO LET THE BPG RANGE INSTALLATION AT A DISTANCE BY 150 MM FROM THE CEILING

SPVSG

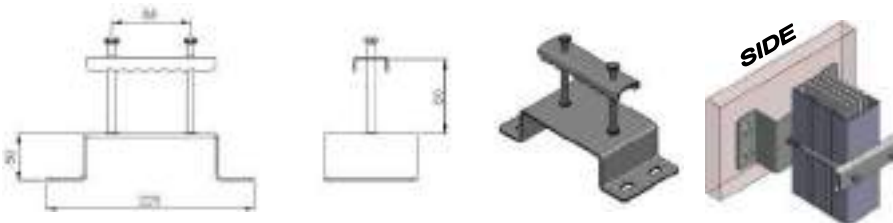

SIMPLE BRACKET FOR VERTICAL RISERS INSTALLATION OF BPG RANGE

SPVBPG

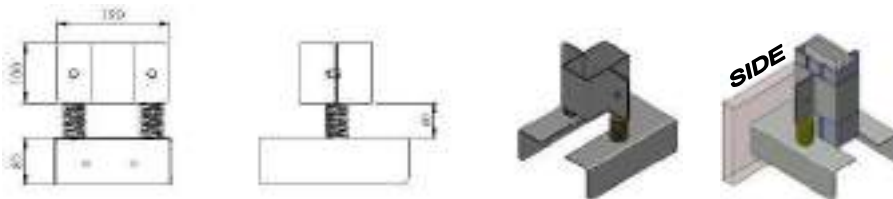

SIMPLE BRACKET WITH SPRINGS FOR VERTICAL RISERS INSTALLATION OF BPG

NAXSOPOWER

DATI TECNICI BP250 E BPG250

		BP250	BPG250
Standards	IEC 60439-2		
Rated insulation voltage / Tensione di isolamento	U_i [V]	1000	1000
Rated operational voltage / Tensione nominale di impegno	U_e [V]	800	800
Exposed conductive part - PE Dimension / Dimensioni involucro - PE	mm	73x33	123x33
Live part cross section / Sezione conduttore	mm ²	109	270
Exposed conductive part - PE Thickness / Spessore involucro - PE	mm	1,1	1,45
Rated Frequency / Frequenza nominale	f [Hz]	50/60	50/60
Exposed conductive part - PE cross section / Sezione dell'involucro - PE	mm ²	230	230
Rated short time withstand current / Corrente di tenuta di breve durata (1 s)	I_{cw} [KA]	9,9	15
Phase resistance at 20°C / fase di resistenza a 20°C	R_{20} [mΩ/m]	0,240	0,161
Phase impedance / fase di impedenza	Z [mΩ/m]	0,30	0,24
Phase reactance (50Hz) / fase di reattanza (50Hz)	X_1 [mΩ/m]	0,2	0,16
Weight 4 conductors / peso 4 conduttori	Kg/m	1,95	6,2
Windows / finestrelle	Nr	5	5
Max Tap-off / Massima spina ammissibile	A	100	200
Tension drop at 100mt full load / caduta di tensione a 100mt a pieno carico	%	8	2,5
Ambient air Temperature range / Temperatura dell'aria ambiente	°C	-5°+40°	-5°+40°
IP standard protection degree / Grado di protezione standard IP	IP	44	44
IP with accessories protection degree / IP con accessori	IP	55	55

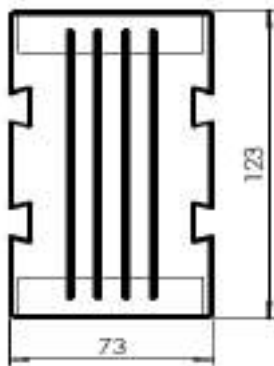

BPG250A
MAX TAP-OFF : 200A

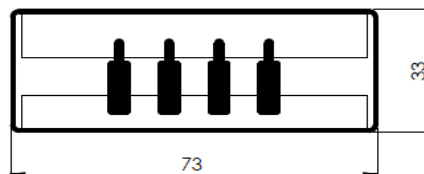

BP250A
MAX TAP-OFF : 100A

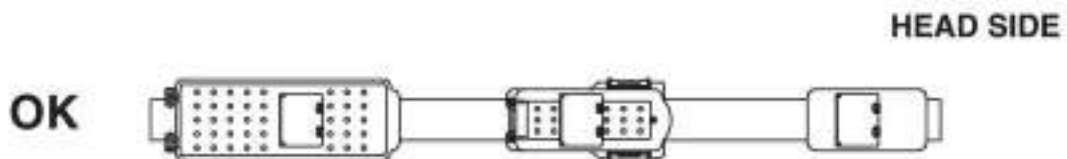
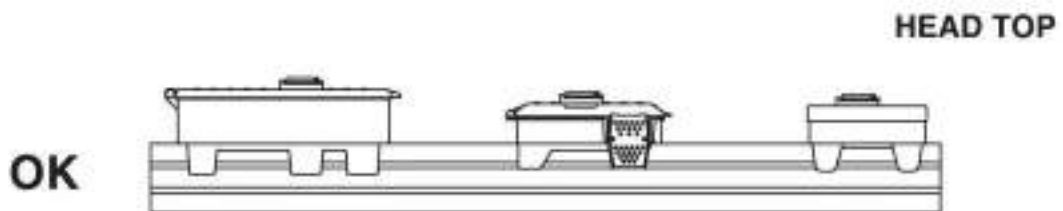
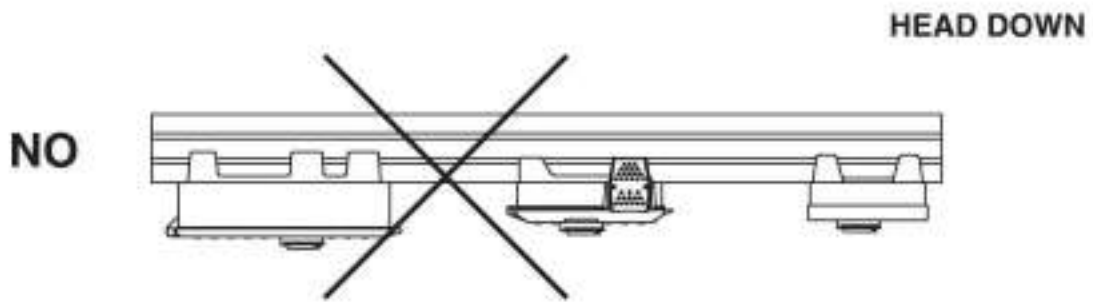
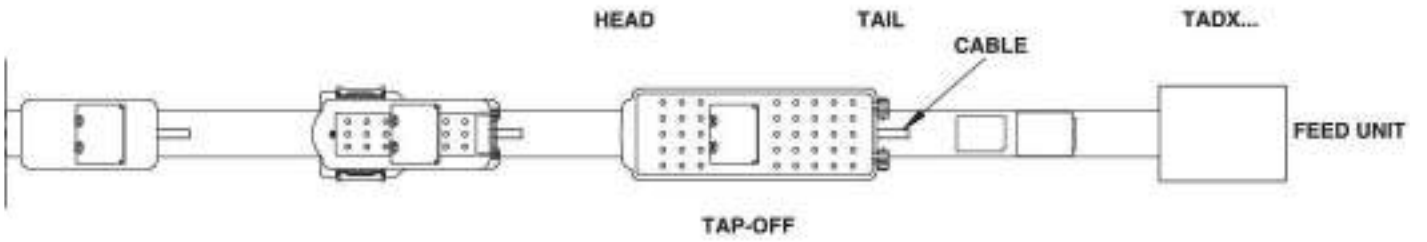
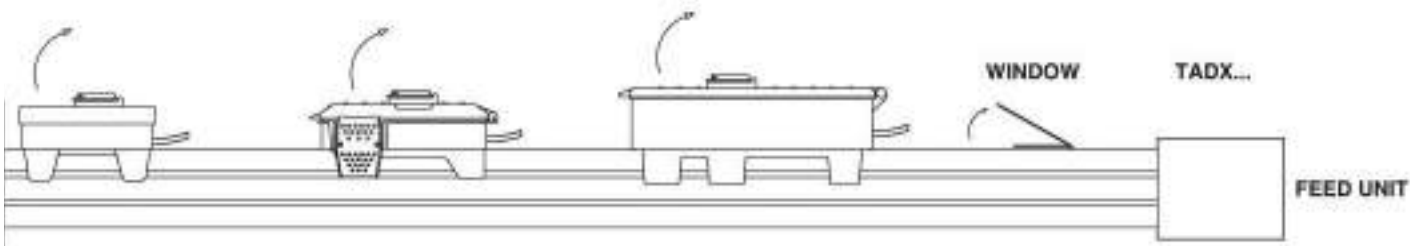



INFORMAZIONI TECNICHE / TECHNICAL INFORMATION

Variazioni della portata (A) in funzione della temperatura vedi norma CEI EN 61439-6 / IEC 61439-6.

Flows of current (A) as a function of temperature see norm CEI EN 61439-6 / IEC 61439-6.

Temperatura ambiente Ambient temperature (°C)	15	20	25	30	35	40	45	50
Moltiplicatore Multiplier	1,15	1,12	1,08	1,05	1,025	1	0,975	0,95

Moltiplicatore di corrente nominale in funzione della temperatura ambiente diversa da 40° C.

Multiplier coefficient of rated current for room temperature values different from 40 ° C.

DATI TECNICI / TECHNICAL DATA

Norme / Norms Conformity		EN 61439-6			
		63	100	160	250
Ingombro del condotto Overall dimension of the busbars	mm	73x33			
Corrente nominale Rated current	In [A]	63	100	160	250
Spessore dell'involucro Overall thickness of the busbar	mm	1,1	1,1	1,1	1,1
Sezione dei conduttori Live part cross section	mm ²	35	40	65	75
Sezione involucro di protezione (Alluminio) PE cross section (Aluminium)	mm ²	230			
Tensione nominale Operational voltage	Ue [V]	400			
Tensione di isolamento Insulational voltage	Ui [V]	690			
Frequenza Frequency	f [Hz]	50/60			
Grado di protezione standard Standard degree of protection	IP	52			
Grado di protezione con accessori Degree of protection with accessories	IP	55			
Corrente ammissibile di breve durata (1 sec.) Rated short-time current (0.1 s)	Icw [kA]	6	10	10	12
Corrente di picco Peak current	Ipk [kA]	11	18	18	21
Resistenza di fase @ 20° C Phase resistance at @ 20° C	R20 [mΩ/m]	0,906	0,871	0,61	0,324
Reattanza @ 50 Hz Reactance @ 50 Hz	Xp [mΩ/m]	0,308	0,308	0,205	0,109
Impedenza di fase Phase impedance	Zp [mΩ/m]	1,305	1,258	0,878	0,466
Resistenza di fase all'equilibrio termico Phase resistance at thermal conditions	Rt [mΩ/m]	1,268	1,219	0,854	0,421
Resistenza del conduttore di protezione Resistance of protective conductor	RPE [mΩ]	0,155	0,155	0,155	0,155
Resistenza anello di guasto Resistance of the fault loop	R0 [mΩ]	1,167	1,129	0,842	0,527
Reattanza @ 50 Hz anello di guasto Reactance of the fault loop at 50 Hz	X0 [mΩ]	0,278	0,278	0,278	0,157
Impedenza anello di guasto Impedance of the fault loop	Z0 [mΩ]	1,2	1,162	0,886	0,55
Caduta di tensione con carico distribuito Voltage drop with distributed load [V/m/A] 10 ⁻³	ΔV[V/m/A] 10 ⁻³ cosφ = 0,70	0,959	0,93	0,644	0,378
	ΔV[V/m/A] 10 ⁻³ cosφ = 0,75	1	0,968	0,672	0,388
	ΔV[V/m/A] 10 ⁻³ cosφ = 0,80	1,039	1,005	0,698	0,395
	ΔV[V/m/A] 10 ⁻³ cosφ = 0,85	1,074	1,038	0,722	0,401
	ΔV[V/m/A] 10 ⁻³ cosφ = 0,90	1,105	1,067	0,743	0,403
	ΔV[V/m/A] 10 ⁻³ cosφ = 0,95	1,127	1,087	0,758	0,4
	ΔV[V/m/A] 10 ⁻³ cosφ = 1	1,098	1,056	0,74	0,365
Peso Weight	p [Kg/m]	6,7	6,7	7,3	7,3
Perdite joule Joule losses I ² r	W / m	15	37	66	79
Temperatura ambiente Ambient temperature min/max	°C	-5°C / +50°C			



INFORMAZIONI TECNICHE / TECHNICAL INFORMATION

Variazioni della portata (A) in funzione della temperatura vedi norma CEI EN 61439-6 / IEC 61439-6.
Flows of current (A) as a function of temperature see norm CEI EN 61439-6 / IEC 61439-6.

Temperatura ambiente Ambient temperature (°C)	15	20	25	30	35	40	45	50
Moltiplicatore Multiplier	1,15	1,12	1,08	1,05	1,025	1	0,975	0,95

Moltiplicatore di corrente nominale in funzione della temperatura ambiente diversa da 40 ° C.
Multiplier coefficient of rated current for room temperature values different from 40 ° C.

DATI TECNICI / TECHNICAL DATA

Norme / Norms Conformity		EN 61439-6				
		250	400	630	800	1000
Ingresso del condotto Overall dimension of the busbars	mm	123x73				
Corrente nominale Rated current	In [A]	250	400	630	800	1000
Spessore dell'involucro Overall thickness of the busbar	mm	1,4				
Sezione dei conduttori Live part cross section	mm ²	218	272	381	530	670
Sezione involucro di protezione (Alluminio) PE cross section (Aluminium)	mm ²	450				
Tensione nominale Operational voltage	Ue [V]	800				
Tensione di isolamento Insulation voltage	Ui [V]	800				
Frequenza Frequency	f [Hz]	50/60				
Grado di protezione standard Standard degree of protection	IP	44				
Grado di protezione con accessori Degree of protection with accessories	IP	55				
Corrente ammissibile di breve durata (1 sec.) Rated short-time current (0.1 s)	Icw [kA]	40			50	
Corrente di picco Peak current	Ipk [kA]	40	84		90	
Resistenza di fase @ 20° C Phase resistance at @ 20° C	R20 [mΩ/m]	0.151	0.087	0.076	0.050	0.042
Reattanza @ 50 Hz Reactance @ 50 Hz	Xp [mΩ/m]	0.047	0.045	0.043	0.041	0.039
Impedenza di fase Phase impedance	Zp [mΩ/m]	0.217	0.130	0.115	0.112	0.110
Resistenza di fase all'equilibrio termico Phase resistance at thermal conditions	Rt [mΩ/m]	0.211	0.122	0.160	0.095	0.080
Resistenza del conduttore di protezione Resistance of protective conductor	RPE [mΩm]	0.071	0.071	0.071	0.071	0.071
Resistenza anello di guasto Resistance of the fault loop	R0 [mΩm]	0.317	0.183	0.160	0.155	0.148
Reattanza @ 50 Hz anello di guasto Reactance of the fault loop at 50 Hz	X0 [mΩm]	0.045	0.042	0.040	0.038	0.036
Impedenza anello di guasto Impedance of the fault loop	Z0 [mΩm]	0.320	0.188	0.165	0.158	0.0145
Caduta di tensione con carico distribuito Voltage drop with distributed load [V/m/A] 10 ⁻³	ΔV[V/m/A] 10 ⁻³ cosΦ = 0,70	0.157	0.102	0.091	0.085	0.070
	ΔV[V/m/A] 10 ⁻³ cosΦ = 0,75	0.164	0.105	0.094	0.089	0.080
	ΔV[V/m/A] 10 ⁻³ cosΦ = 0,80	0.171	0.108	0.096	0.092	0.088
	ΔV[V/m/A] 10 ⁻³ cosΦ = 0,85	0.177	0.108	0.096	0.094	0.090
	ΔV[V/m/A] 10 ⁻³ cosΦ = 0,90	0.183	0.110	0.099	0.096	0.092
	ΔV[V/m/A] 10 ⁻³ cosΦ = 0,95	0.187	0.112	0.099	0.098	0.096
	ΔV[V/m/A] 10 ⁻³ cosΦ = 1	0.183	0.105	0.092	0.08	0.075
Peso Weight	p [Kg/m]	5,4	6	7	7,8	8,2
Perdite joule Joule losses i ² r	W / m	28	42	90	120	150
Temperatura ambiente Ambient temperature min/max	°C	-5°C / +40°C				



BP40 A30

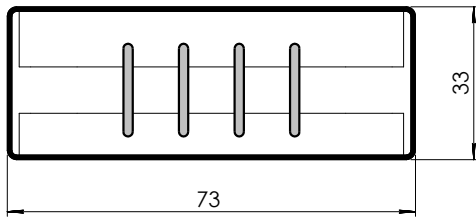

Conductor



Housing	AL 6060 T6
Dimension	73 X 33 mm
Area (PE)	224 mm ²
Thickness	1,1 mm
Equivalent in copper	130 mm ²
Perimetral	207 mm
Conductors N included	15 X 2 mm
Conductor cross section	28 mm ²
Conductors alloy	AL 6060 T6
Support polyamide	CTI >600
Supports temperature	Class B
Joint support polyamide	Class B
Joint live parts copper beryllium TIN plated	
Windows (5) polyamide	Class B
Joint frame GI 1,5	460 mm ²

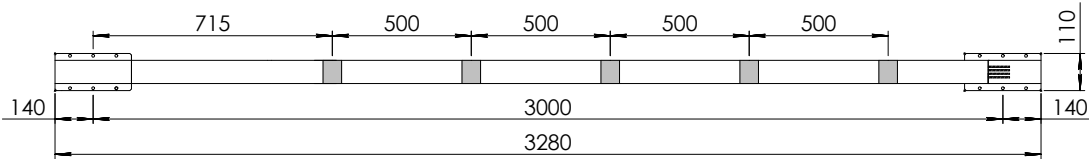

28/01/2014



BP63 A30

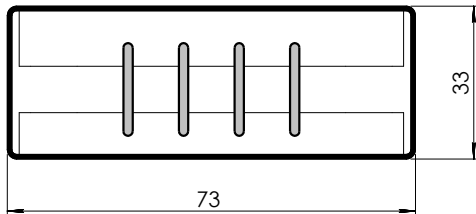

Conductor

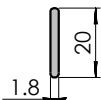

Housing	AL 6060 T6
Dimension	73 X 33 mm
Area (PE)	224 mm ²
Thickness	1,1 mm
Equivalent in copper	130 mm ²
Perimetral	207 mm
Conductors N included	20 X 1,8 mm
Conductor cross section	34 mm ²
Conductors alloy	AL 6060 T6
Support polyamide	CTI >600
Supports temperature	Class B
Joint support polyamide	Class B
Joint live parts copper beryllium TIN plated	
Windows (5) polyamide	Class B
Joint frame GI 1,5	460 mm ²

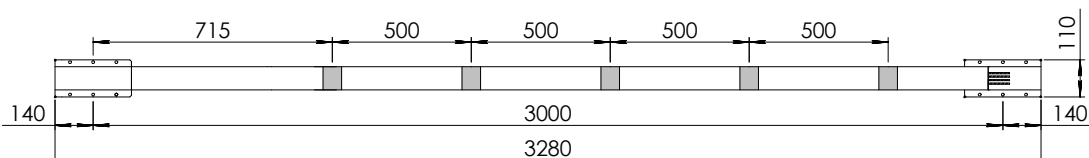

28/01/2014



BP100 A30

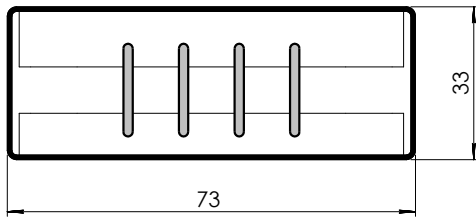

Conductor

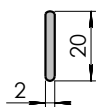

Housing	AL 6060 T6
Dimension	73 X 33 mm
Area (PE)	224 mm ²
Thickness	1,1 mm
Equivalent in copper	130 mm ²
Perimetral	207 mm
Conductors N included	20 X 2 mm
Conductor cross section	38 mm ²
Conductors alloy	AL 6060 T6
Support polyamide	CTI >600
Supports temperature	Class B
Joint support polyamide	Class B
Joint live parts copper beryllium TIN plated	
Windows (5) polyamide	Class B
Joint frame GI 1,5	460 mm ²

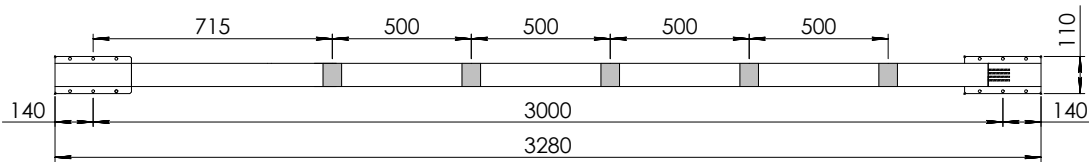

28/01/2014



BP160 A30

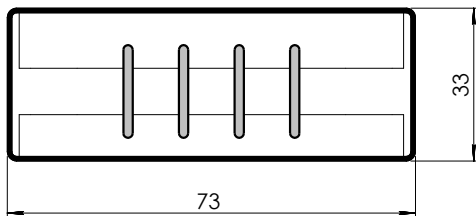

Conductor

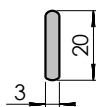

Housing	AL 6060 T6
Dimension	73 X 33 mm
Area (PE)	224 mm ²
Thickness	1,1
Equivalent in copper	130 mm ²
Perimetral	207 mm
Conductors N included	20 X 3 mm
Conductor cross section	57 mm ²
Conductors alloy	AL 6060 T6
Support polyamide	CTI >600
Supports temperature	Class B
Joint support polyamide	Class B
Joint live parts copper beryllium TIN plated	
Windows (5) polyamide	Class B
Joint frame GI 1,5	460 mm ²

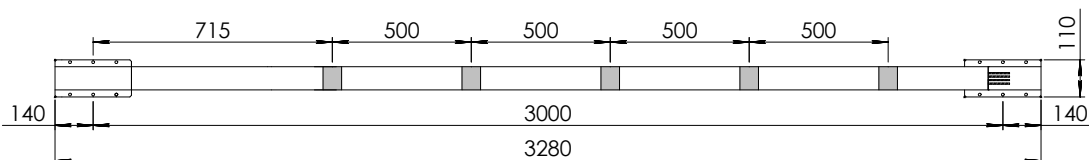

28/01/2014



BP200 A30

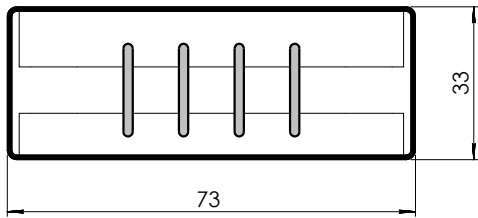

Housing	AL 6060 T6
Dimension	73 X 33 mm
Area (PE)	224 mm ²
Thickness	1,1 mm
Equivalent in copper	130 mm ²
Perimetral	207 mm
Conductors N included	22 X 3,3 mm
Conductor cross section	72 mm ²
Conductors alloy	AL 6060 T6
Support polyamide	CTI >600
Supports temperature	Class B
Joint support polyamide	Class B
Joint live parts copper beryllium TIN plated	
Windows (5) polyamide	Class B
Joint frame GI 1,5	460 mm ²

Conductor

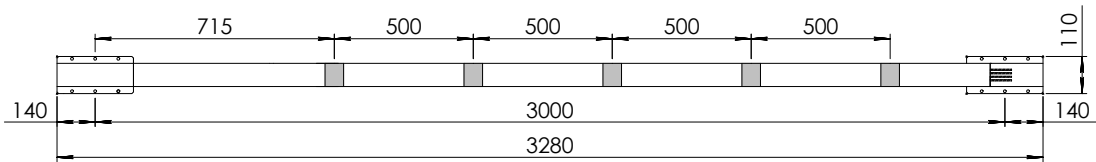
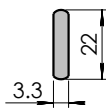

28/01/2014



BPG250A30CC

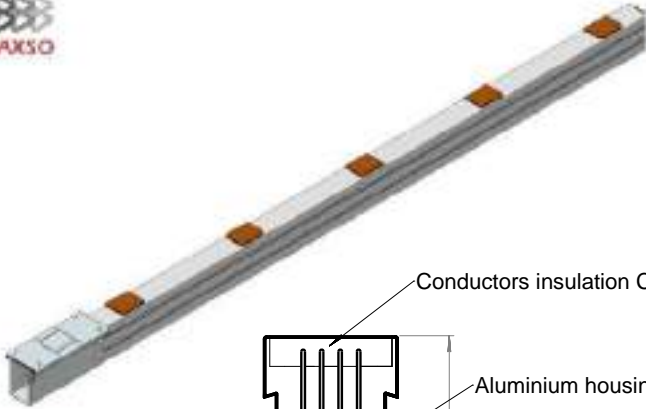

Rated Current	250A 4P AL
Protection Degree	IP44
Housing	AL 6060 T6
Dimension	123 X 73 mm
Area (PE) Housing cross section (AL)	627 mm ²
Thickness	1,4 mm
Equivalent in copper	345 mm ²
Perimetral	478 mm
Conductors N included	109 X 2 mm
Conductor cross section	216 mm ²
Conductors alloy	AL 6060 T6
Support polyamide	CTI >600
Supports temperature	Class B
Joint support polyamide	Class B
Joint live parts copper beryllium TIN plated	
Windows (5) polyamide	Class B
Joint frame GI 1,5	710 mm ²
Short-Circuit (Peak) (Ipk)	16,5 kA
Short-Circuit (Peak) Tested 1 msec. (Icw)	8 kA
Resistance (R20)	0,288 mΩ/m
Reactance (X)	0,095 mΩ/m
Impedance (Z)	0,397 mΩ/m
Joule losses At In (I2r)	49,3 W/m

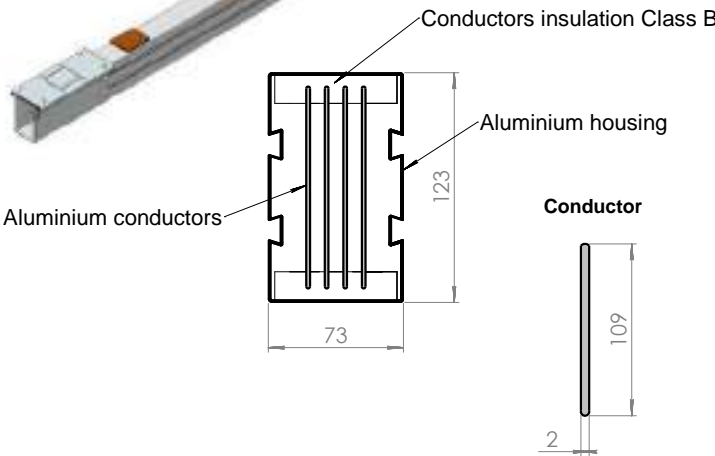



Conductors insulation Class B

Aluminium housing

Aluminium conductors

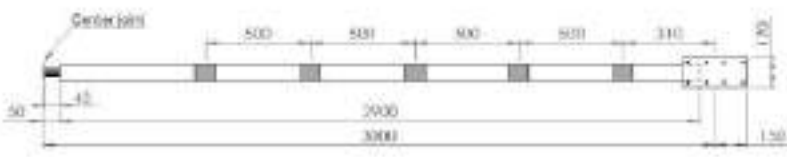
Conductor





BPG250A305C

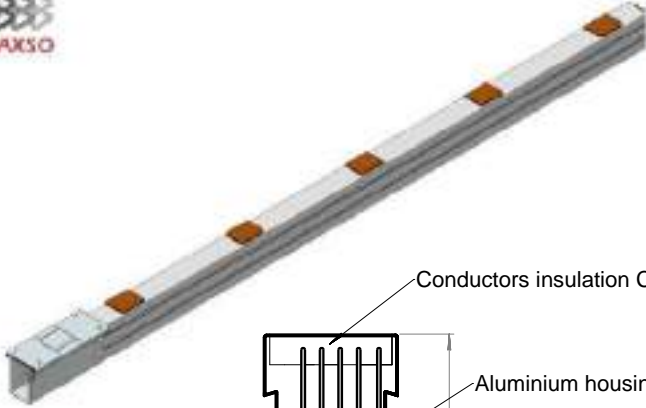

Rated Current	250A 5P AL
Protection Degree	IP44
Housing	AL 6060 T6
Dimension	123 X 73 mm
Area (PE) Housing cross section (AL)	627 mm ²
Thickness	1,4 mm
Equivalent in copper	345 mm ²
Perimetral	478 mm
Conductors N included	109 X 2 mm
Conductor cross section	216 mm ²
Conductors alloy	AL 6060 T6
Support polyamide	CTI >600
Supports temperature	Class B
Joint support polyamide	Class B
Joint live parts copper beryllium TIN plated	
Windows (5) polyamide	Class B
Joint frame GI 1,5	710 mm ²
Short-Circuit (Peak) (Ipk)	16,5 kA
Short-Circuit (Peak) Tested 1 msec. (Icw)	8 kA
Resistance (R20)	0,288 mΩ/m
Reactance (X)	0,095 mΩ/m
Impedance (Z)	0,397 mΩ/m
Joule losses At In (I2r)	49,3 W/m

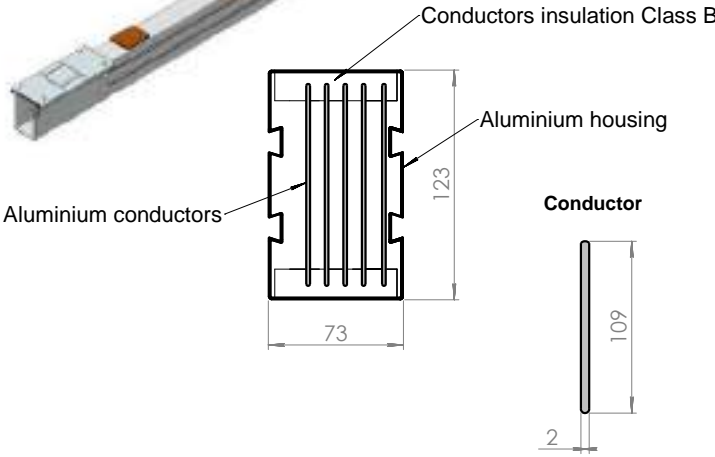

Conductors insulation Class B

Aluminium housing

Aluminium conductors

Conductor

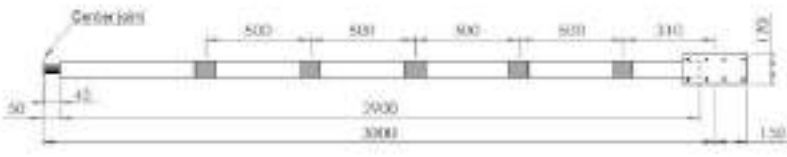



BPG400A30CC

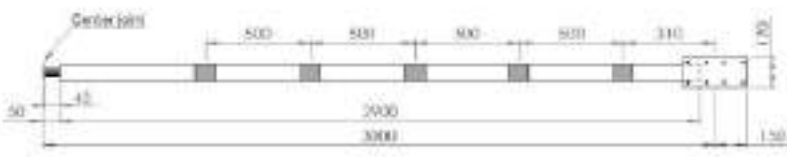
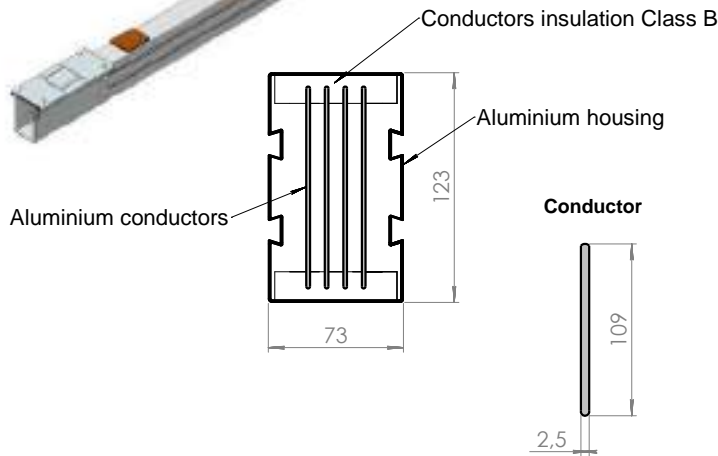
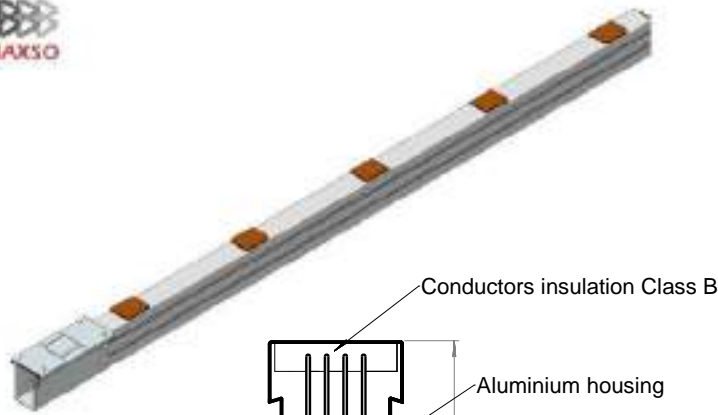

Rated Current	400A 4P AL
Protection Degree	IP44
Housing	AL 6060 T6
Dimension	123 X 73 mm
Area (PE) Housing cross section (AL)	627 mm ²
Thickness	1,4 mm
Equivalent in copper	345 mm ²
Perimetral	478 mm
Conductors N included	109 X 2,5 mm
Conductor cross section	271 mm ²
Conductors alloy	AL 6060 T6
Support polyamide	CTI >600
Supports temperature	Class B
Joint support polyamide	Class B
Joint live parts copper beryllium TIN plated	
Windows (5) polyamide	Class B
Joint frame GI 1,5	710 mm ²
Short-Circuit (Peak) (I _{pk})	16,5 kA
Short-Circuit (Peak) Tested 1 msec. (I _{cw})	8 kA
Resistance (R ₂₀)	0,223 mΩ/m
Reactance (X)	0,093 mΩ/m
Impedance (Z)	0,311 mΩ/m
Joule losses At I _n (I _{2r})	55,1 W/m



BPG400A305C

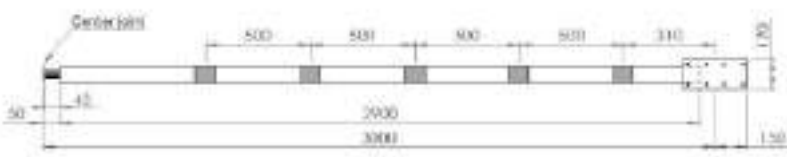
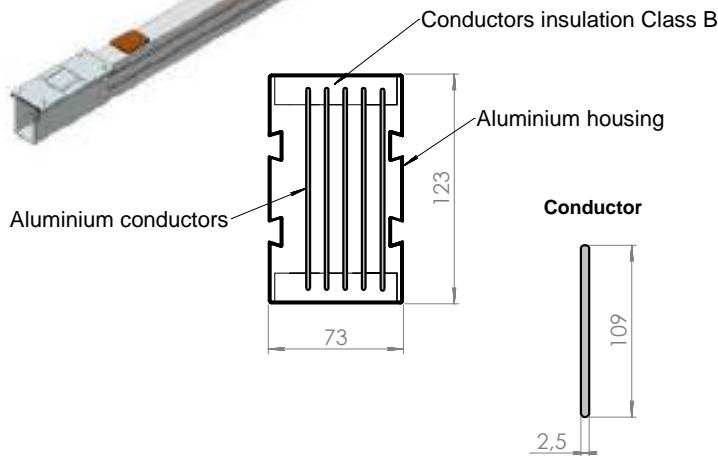
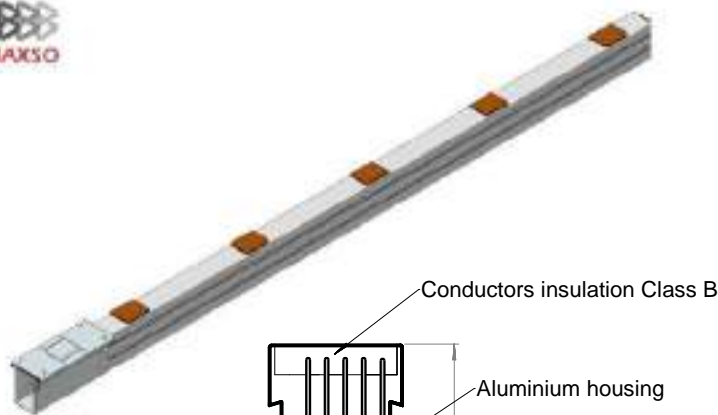

Rated Current	400A 5P AL
Protection Degree	IP44
Housing	AL 6060 T6
Dimension	123 X 73 mm
Area (PE) Housing cross section (AL)	627 mm ²
Thickness	1,4 mm
Equivalent in copper	345 mm ²
Perimetral	478 mm
Conductors N included	109 X 2,5 mm
Conductor cross section	271 mm ²
Conductors alloy	AL 6060 T6
Support polyamide	CTI >600
Supports temperature	Class B
Joint support polyamide	Class B
Joint live parts copper beryllium TIN plated	
Windows (5) polyamide	Class B
Joint frame GI 1,5	710 mm ²
Short-Circuit (Peak) (I _{pk})	16,5 kA
Short-Circuit (Peak) Tested 1 msec. (I _{cw})	8 kA
Resistance (R ₂₀)	0,223 mΩ/m
Reactance (X)	0,093 mΩ/m
Impedance (Z)	0,311 mΩ/m
Joule losses At I _n (I _{2r})	55,1 W/m

NAXSOPOWER

BPG400A305CSP

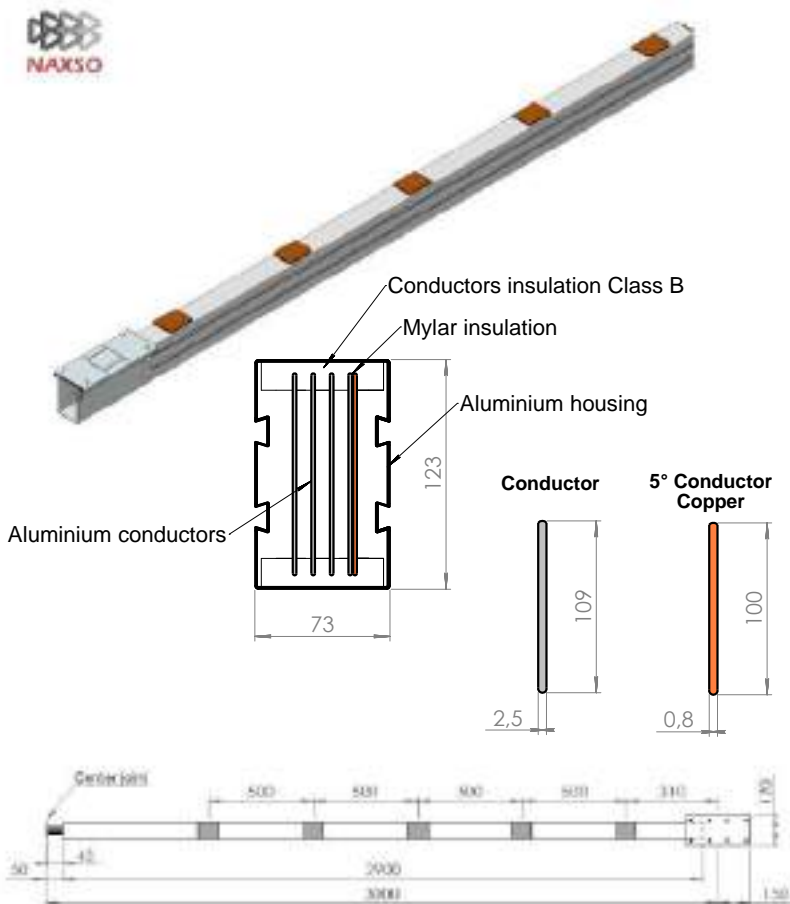

Rated Current	400A 5P AL
Protection Degree	IP44
Housing	AL 6060 T6
Dimension	123 X 73 mm
Area (PE) Housing cross section (AL)	627 mm ²
Thickness	1,4 mm
Equivalent in copper	345 mm ²
Perimetral	478 mm
Conductors N included	109 X 2,5 mm
Conductor cross section	271 mm ²
Conductors alloy	AL 6060 T6
Support polyamide	CTI >600
5° conductors	100 X 0,8 mm
5° Conductors alloy	Copper
Supports temperature	Class B
Joint support polyamide	Class B
Joint live parts copper beryllium TIN plated	
Windows (5) polyamide	Class B
Joint frame GI 1,5	710 mm ²
Short-Circuit (Peak) (Ipk)	16,5 kA
Short-Circuit (Peak) Tested 1 msec. (Icw)	8 kA
Resistance (R20)	0,223 mΩ/m
Reactance (X)	0,093 mΩ/m
Impedance (Z)	0,311 mΩ/m
Joule losses At In (I2r)	55,1 W/m

BPG630A30CC

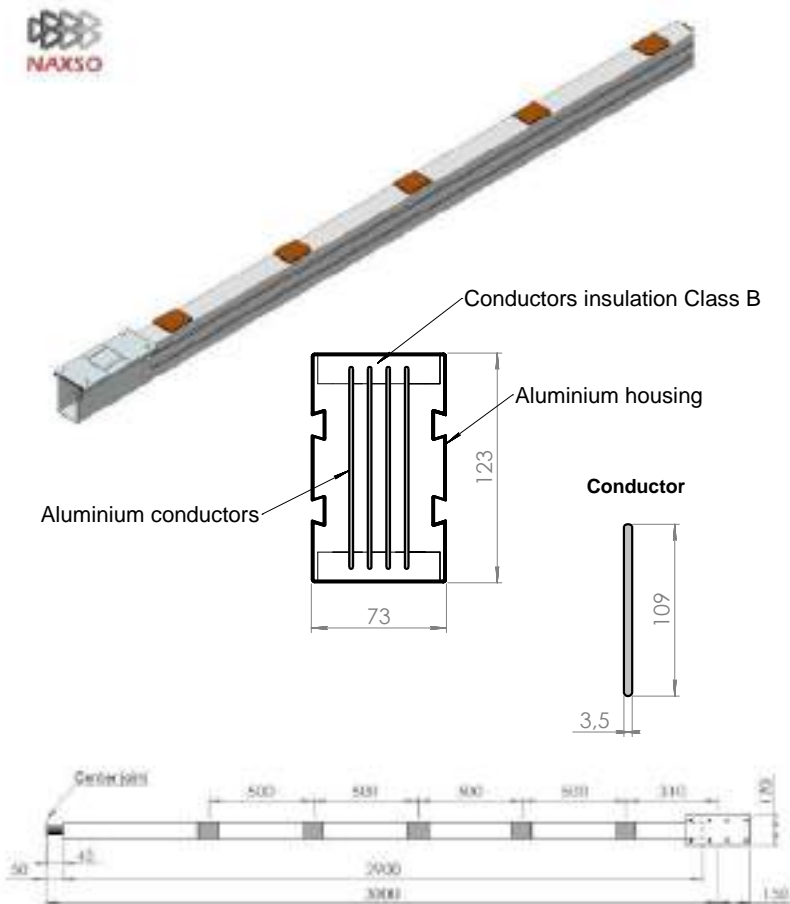

Rated Current	630A 4P AL
Protection Degree	IP44
Housing	AL 6060 T6
Dimension	123 X 73 mm
Area (PE) Housing cross section (AL)	627 mm ²
Thickness	1,4 mm
Equivalent in copper	345 mm ²
Perimetral	478 mm
Conductors N included	109 X 3,5 mm
Conductor cross section	379 mm ²
Conductors alloy	AL 6060 T6
Support polyamide	CTI >600
Supports temperature	Class B
Joint support polyamide	Class B
Joint live parts copper beryllium TIN plated	
Windows (5) polyamide	Class B
Joint frame GI 1,5	710 mm ²
Short-Circuit (Peak) (Ipk)	35 kA
Short-Circuit (Peak) Tested 1 msec. (Icw)	18 kA
Resistance (R20)	0,112 mΩ/m
Reactance (X)	0,075 mΩ/m
Impedance (Z)	0,194 mΩ/m
Joule losses At In (I2r)	79,5 W/m

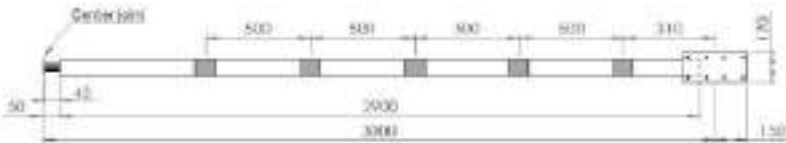
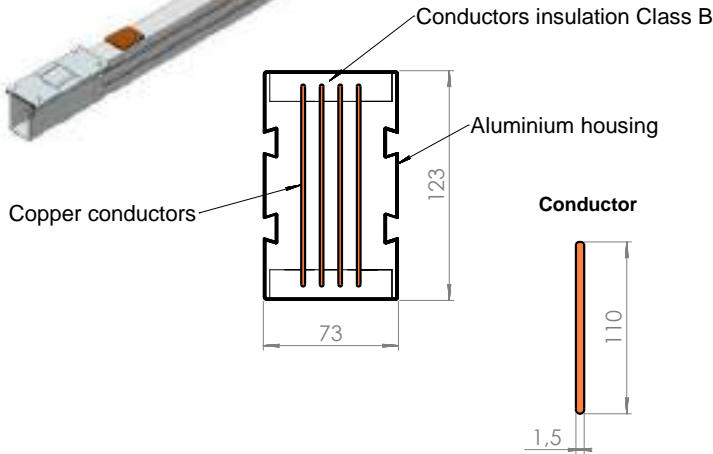
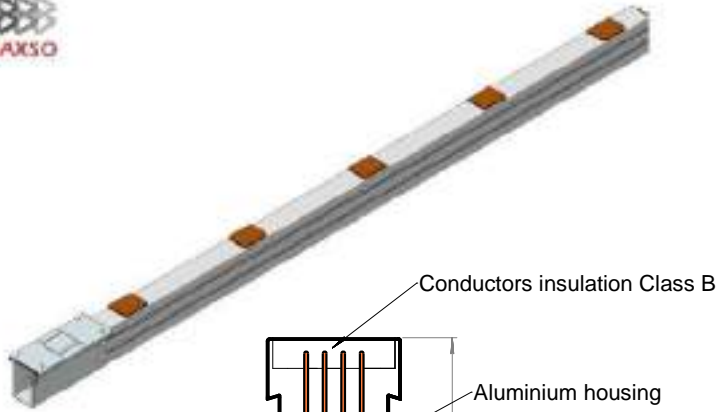

BPG630A30CU

Rated Current	630A 4P CU
Protection Degree	IP44
Housing	AL 6060 T6
Dimension	123 X 73 mm
Area (PE) Housing cross section (AL)	627 mm ²
Thickness	1,4 mm
Equivalent in copper	345 mm ²
Perimetral	478 mm
Conductors N included	110 X 1,5 mm
Conductor cross section	165 mm ²
Conductors alloy	Copper
Support polyamide	CTI >600
Supports temperature	Class B
Joint support polyamide	Class B
Joint live parts copper beryllium TIN plated	
Windows (5) polyamide	Class B
Joint frame GI 1,5	710 mm ²
Short-Circuit (Peak) (I _{pk})	35 kA
Short-Circuit (Peak) Tested 1 msec. (I _{cw})	18 kA
Resistance (R ₂₀)	0,098 mΩ/m
Reactance (X)	0,075 mΩ/m
Impedance (Z)	0,152 mΩ/m
Joule losses At I _n (I _{2r})	73,2 W/m

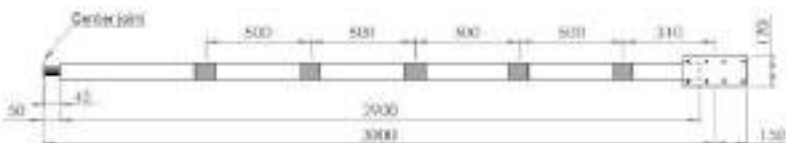
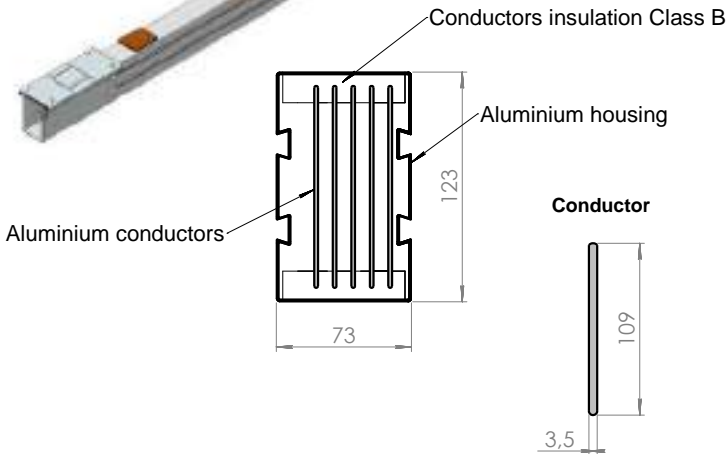
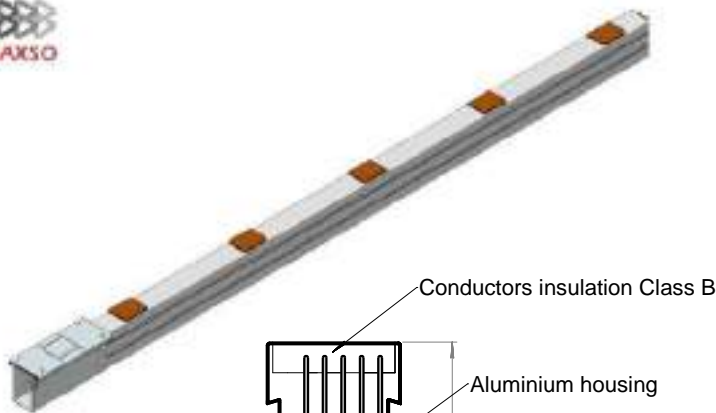

BPG630A305C

Rated Current	630A 5P AL
Protection Degree	IP44
Housing	AL 6060 T6
Dimension	123 X 73 mm
Area (PE) Housing cross section (AL)	627 mm ²
Thickness	1,4 mm
Equivalent in copper	345 mm ²
Perimetral	478 mm
Conductors N included	109 X 3,5 mm
Conductor cross section	379 mm ²
Conductors alloy	AL 6060 T6
Support polyamide	CTI >600
Supports temperature	Class B
Joint support polyamide	Class B
Joint live parts copper beryllium TIN plated	
Windows (5) polyamide	Class B
Joint frame GI 1,5	710 mm ²
Short-Circuit (Peak) (I _{pk})	35 kA
Short-Circuit (Peak) Tested 1 msec. (I _{cw})	18 kA
Resistance (R ₂₀)	0,112 mΩ/m
Reactance (X)	0,075 mΩ/m
Impedance (Z)	0,194 mΩ/m
Joule losses At I _n (I _{2r})	79,5 W/m

NAXSOPOWER



BPG800A30CC

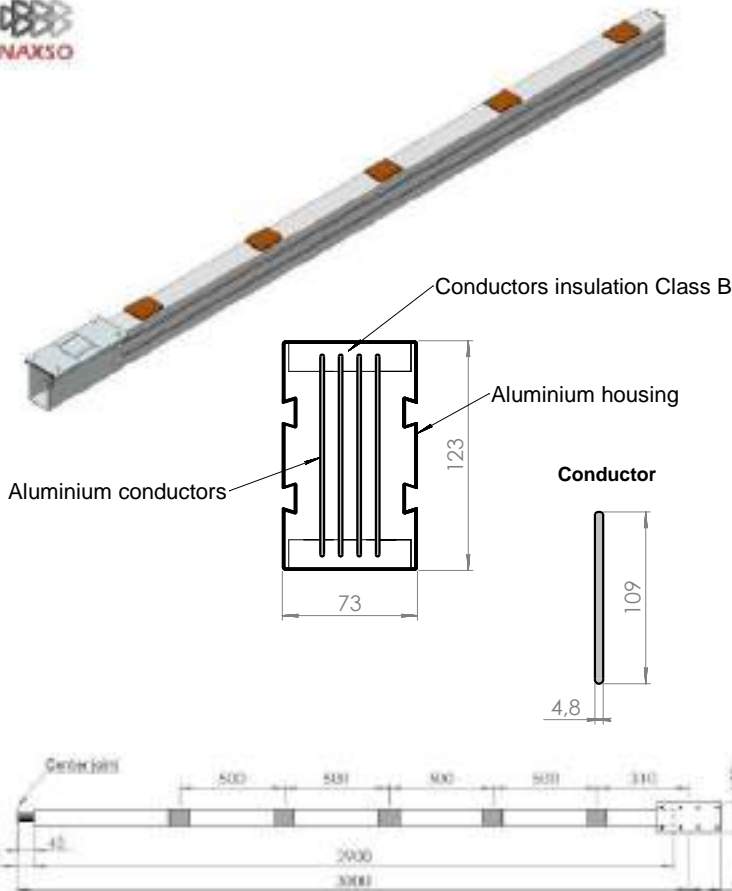

Rated Current	800A 4P AL
Protection Degree	IP44
Housing	AL 6060 T6
Dimension	123 X 73 mm
Area (PE) Housing cross section (AL)	627 mm ²
Thickness	1,4 mm
Equivalent in copper	345 mm ²
Perimetral	478 mm
Conductors N included	109 X 4,8 mm
Conductor cross section	515 mm ²
Conductors alloy	AL 6060 T6
Support polyamide	CTI >600
Supports temperature	Class B
Joint support polyamide	Class B
Joint live parts copper beryllium TIN plated	
Windows (5) polyamide	Class B
Joint frame GI 1,5	710 mm ²
Short-Circuit (Peak) (I _{pk})	35 kA
Short-Circuit (Peak) Tested 1 msec. (I _{cw})	18 kA
Resistance (R ₂₀)	0,084 mΩ/m
Reactance (X)	0,070 mΩ/m
Impedance (Z)	0,144 mΩ/m
Joule losses At I _n (I _{2r})	107,3 W/m



BPG800A30CU

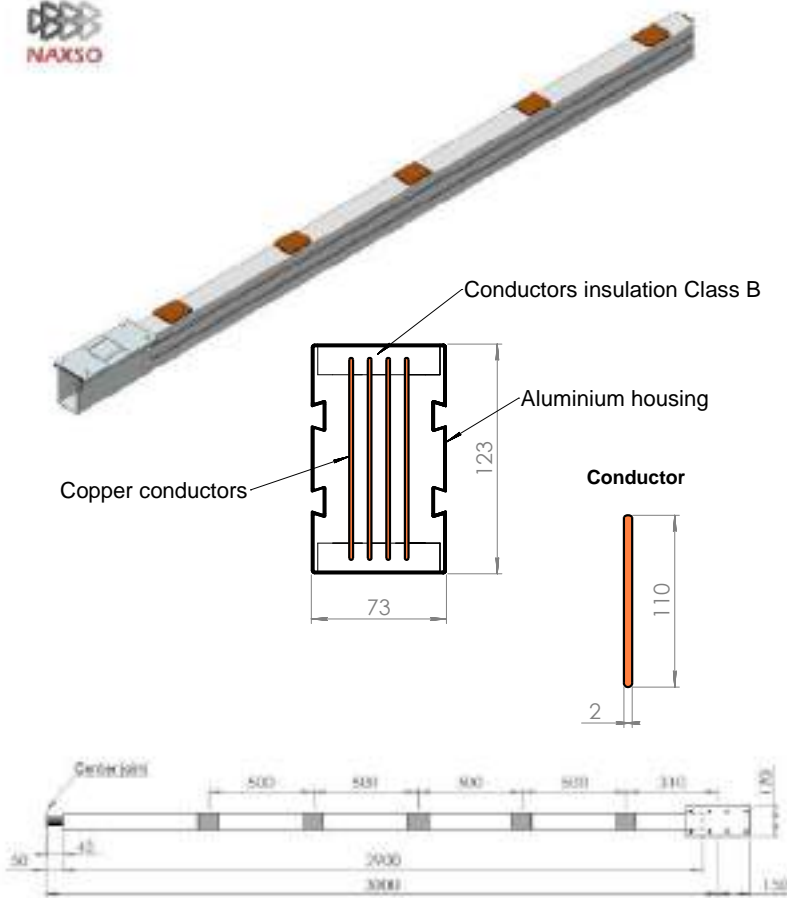

Rated Current	800A 4P CU
Protection Degree	IP44
Housing	AL 6060 T6
Dimension	123 X 73 mm
Area (PE) Housing cross section (AL)	627 mm ²
Thickness	1,4 mm
Equivalent in copper	345 mm ²
Perimetral	478 mm
Conductors N included	110 X 2 mm
Conductor cross section	220 mm ²
Conductors alloy	Copper
Support polyamide	CTI >600
Supports temperature	Class B
Joint support polyamide	Class B
Joint live parts copper beryllium TIN plated	
Windows (5) polyamide	Class B
Joint frame GI 1,5	710 mm ²
Short-Circuit (Peak) (I _{pk})	35 kA
Short-Circuit (Peak) Tested 1 msec. (I _{cw})	18 kA
Resistance (R ₂₀)	0,072 mΩ/m
Reactance (X)	0,070 mΩ/m
Impedance (Z)	0,111 mΩ/m
Joule losses At I _n (I _{2r})	100,8 W/m

NAXSOPOWER



BPG800A305C

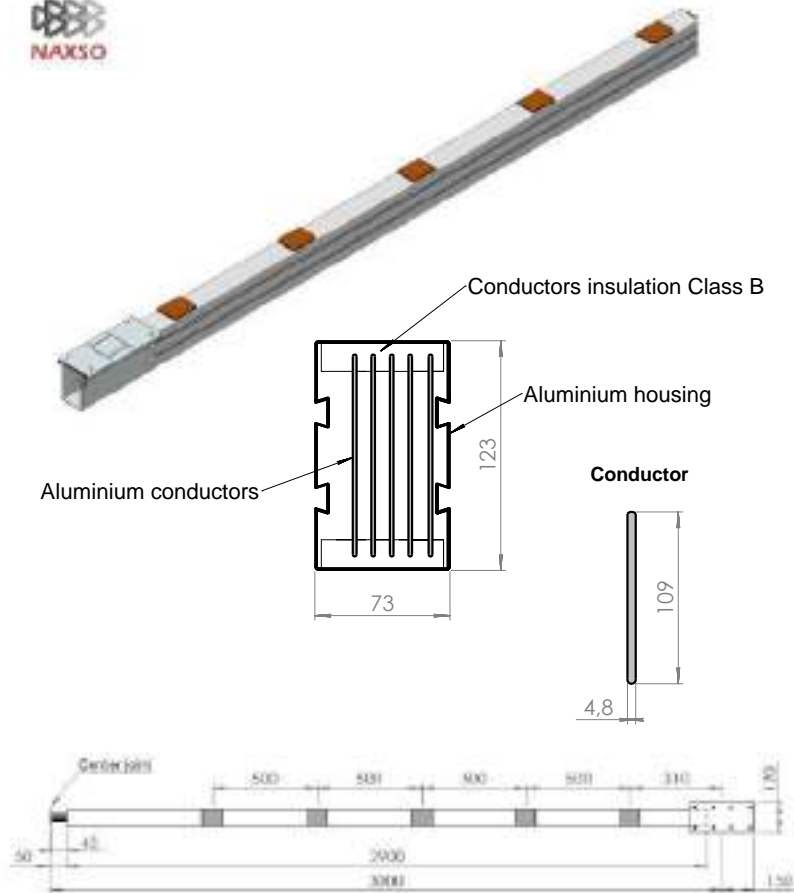

Rated Current	800A 5P AL
Protection Degree	IP44
Housing	AL 6060 T6
Dimension	123 X 73 mm
Area (PE) Housing cross section (AL)	627 mm ²
Thickness	1,4 mm
Equivalent in copper	345 mm ²
Perimetral	478 mm
Conductors N included	109 X 4,8 mm
Conductor cross section	515 mm ²
Conductors alloy	AL 6060 T6
Support polyamide	CTI >600
Supports temperature	Class B
Joint support polyamide	Class B
Joint live parts copper beryllium TIN plated	
Windows (5) polyamide	Class B
Joint frame GI 1,5	710 mm ²
Short-Circuit (Peak) (Ipk)	35 kA
Short-Circuit (Peak) Tested 1 msec. (Icw)	18 kA
Resistance (R20)	0,084 mΩ/m
Reactance (X)	0,070 mΩ/m
Impedance (Z)	0,144 mΩ/m
Joule losses At In (I2r)	107,3 W/m



BPG1000A30CC

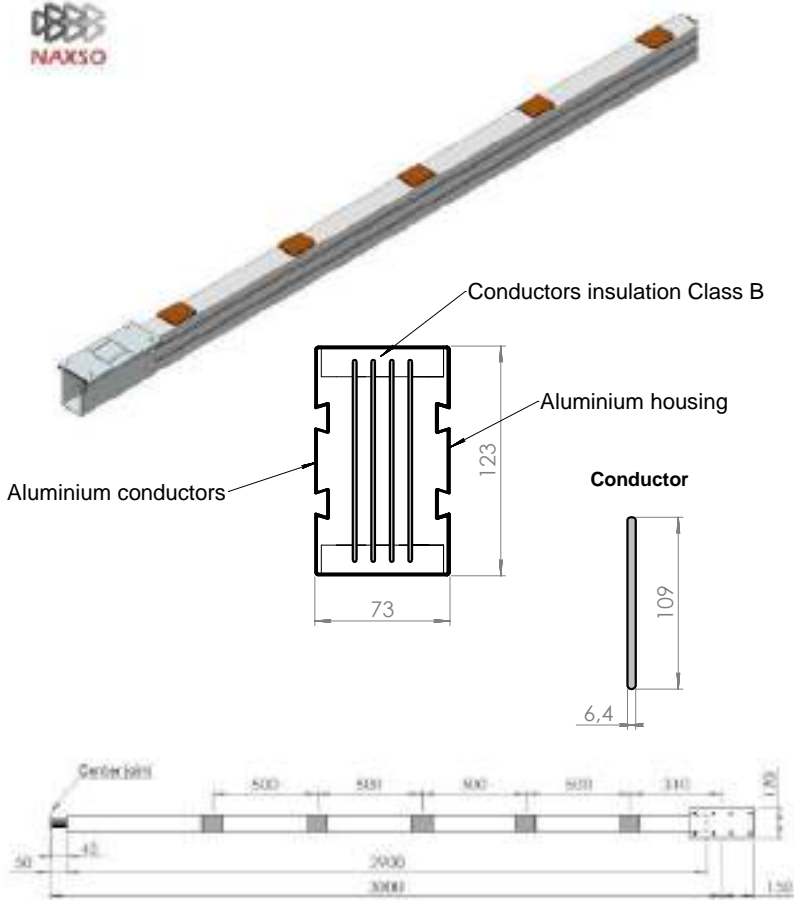

Rated Current	1000A 4P AL
Protection Degree	IP44
Housing	AL 6060 T6
Dimension	123 X 73 mm
Area (PE) Housing cross section (AL)	627 mm ²
Thickness	1,4 mm
Equivalent in copper	345 mm ²
Perimetral	478 mm
Conductors N included	109 X 6,4 mm
Conductor cross section	665 mm ²
Conductors alloy	AL 6060 T6
Support polyamide	CTI >600
Supports temperature	Class B
Joint support polyamide	Class B
Joint live parts copper beryllium TIN plated	
Windows (5) polyamide	Class B
Joint frame GI 1,5	710 mm ²
Short-Circuit (Peak) (Ipk)	35 kA
Short-Circuit (Peak) Tested 1 msec. (Icw)	18 kA
Resistance (R20)	0,062 mΩ/m
Reactance (X)	0,064 mΩ/m
Impedance (Z)	0,112 mΩ/m
Joule losses At In (I2r)	157,4 W/m



BPG1000A30CU

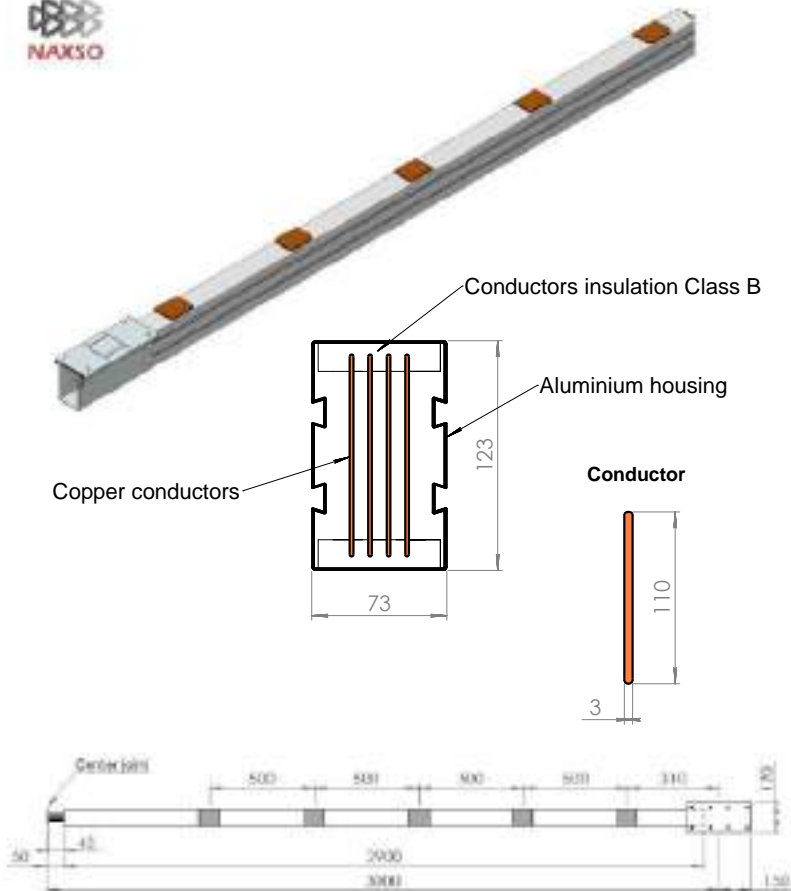

Rated Current	1000A 4P CU
Protection Degree	IP44
Housing	AL 6060 T6
Dimension	123 X 73 mm
Area (PE) Housing cross section (AL)	627 mm ²
Thickness	1,4 mm
Equivalent in copper	345 mm ²
Perimetral	478 mm
Conductors N included	110 X 3 mm
Conductor cross section	330 mm ²
Conductors alloy	Copper
Support polyamide	CTI >600
Supports temperature	Class B
Joint support polyamide	Class B
Joint live parts copper beryllium TIN plated	
Windows (5) polyamide	Class B
Joint frame GI 1,5	710 mm ²
Short-Circuit (Peak) (Ipk)	35 kA
Short-Circuit (Peak) Tested 1 msec. (Icw)	18 kA
Resistance (R20)	0,049 mΩ/m
Reactance (X)	0,061 mΩ/m
Impedance (Z)	0,097 mΩ/m
Joule losses At In (I2r)	132,8 W/m



BPG1000A305C

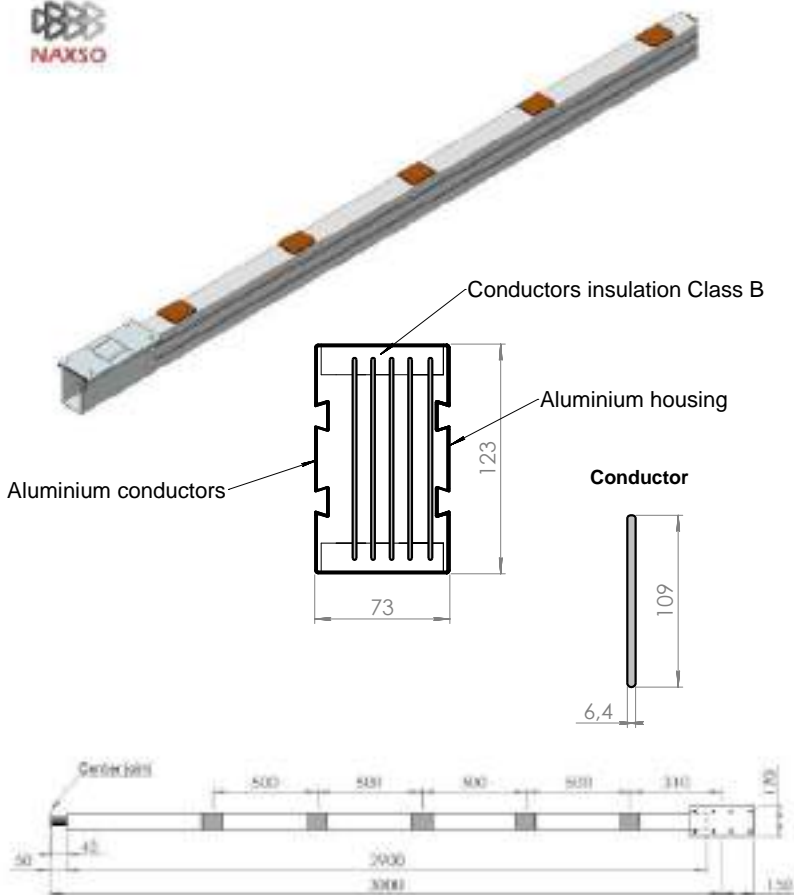

Rated Current	1000A 5P AL
Protection Degree	IP44
Housing	AL 6060 T6
Dimension	123 X 73 mm
Area (PE) Housing cross section (AL)	627 mm ²
Thickness	1,4 mm
Equivalent in copper	345 mm ²
Perimetral	478 mm
Conductors N included	109 X 6,4 mm
Conductor cross section	665 mm ²
Conductors alloy	AL 6060 T6
Support polyamide	CTI >600
Supports temperature	Class B
Joint support polyamide	Class B
Joint live parts copper beryllium TIN plated	
Windows (5) polyamide	Class B
Joint frame GI 1,5	710 mm ²
Short-Circuit (Peak) (Ipk)	35 kA
Short-Circuit (Peak) Tested 1 msec. (Icw)	18 kA
Resistance (R20)	0,062 mΩ/m
Reactance (X)	0,064 mΩ/m
Impedance (Z)	0,112 mΩ/m
Joule losses At In (I2r)	157,4 W/m



BPK250A30CU

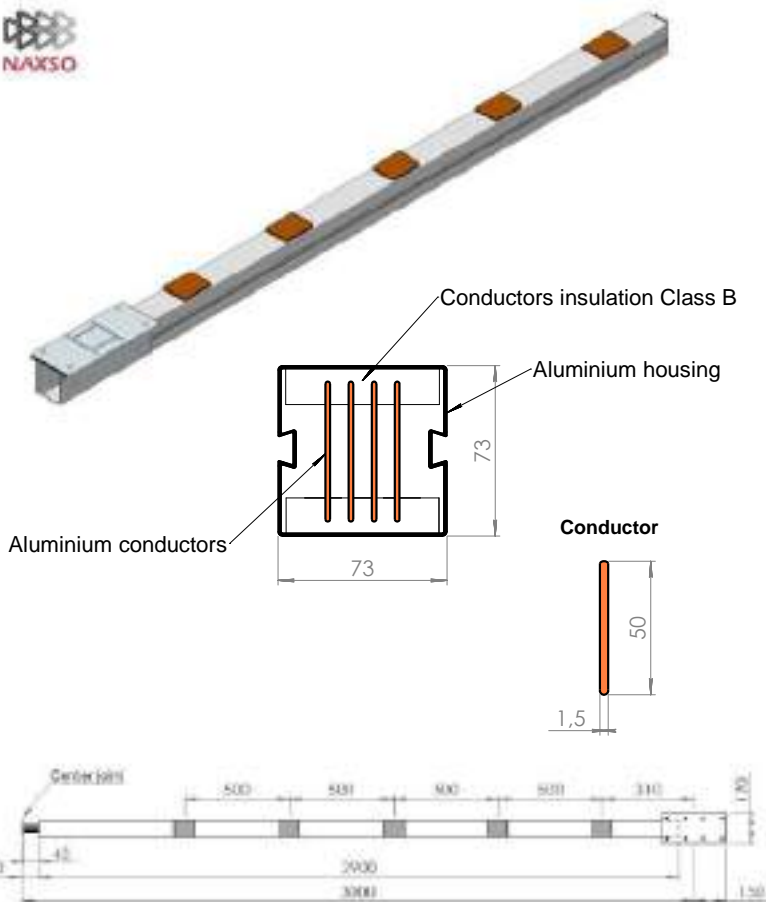

Rated Current	250A 4P CU
Protection Degree	IP44
Housing	AL 6060 T6
Dimension	73 X 73 mm
Area (PE) Housing cross section (AL)	333 mm ²
Thickness	1,1 mm
Equivalent in copper	190 mm ²
Perimetral	377 mm
Conductors N included	50 X 1,5 mm
Conductor cross section	75 mm ²
Conductors alloy	Copper
Support polyamide	CTI >600
Supports temperature	Class B
Joint support polyamide	Class B
Joint live parts copper beryllium TIN plated	
Windows (5) polyamide	Class B
Joint frame GI 1,5	560 mm ²
Short-Circuit (Peak) (I _{pk})	16,5 kA
Short-Circuit (Peak) Tested 1 msec. (I _{cw})	8 kA
Resistance (R ₂₀)	0,192 mΩ/m
Reactance (X)	0,102 mΩ/m
Impedance (Z)	0,257 mΩ/m
Joule losses At I _n (I _{2r})	36,3 W/m



BPK400A30CU

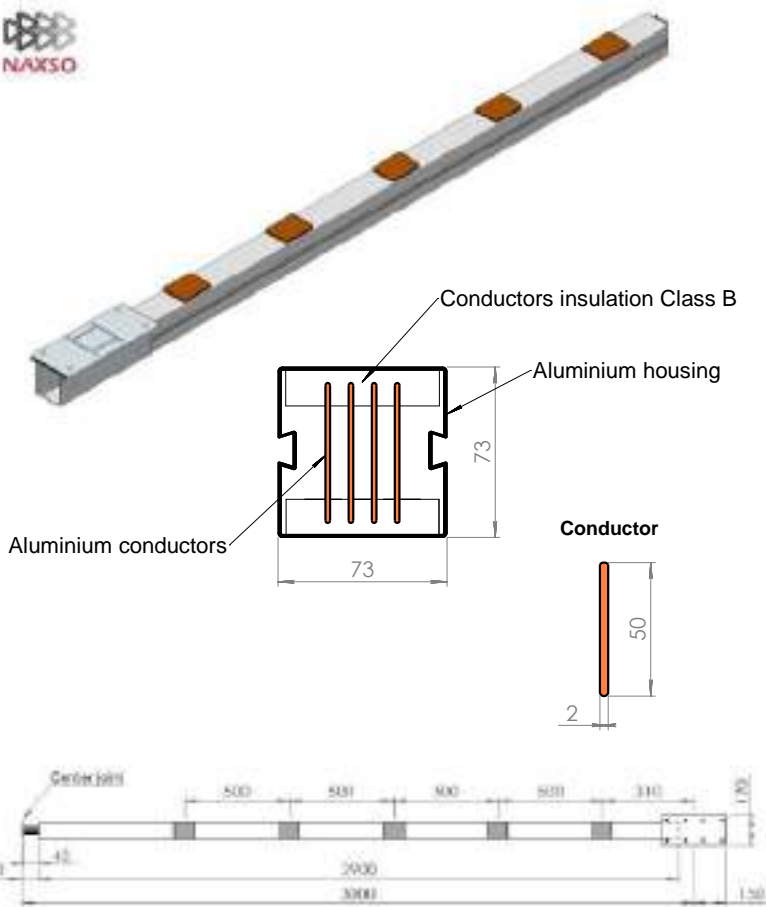

Rated Current	400A 4P CU
Protection Degree	IP44
Housing	AL 6060 T6
Dimension	73 X 73 mm
Area (PE) Housing cross section (AL)	333 mm ²
Thickness	1,1 mm
Equivalent in copper	190 mm ²
Perimetral	377 mm
Conductors N included	50 X 2 mm
Conductor cross section	100 mm ²
Conductors alloy	Copper
Support polyamide	CTI >600
Supports temperature	Class B
Joint support polyamide	Class B
Joint live parts copper beryllium TIN plated	
Windows (5) polyamide	Class B
Joint frame GI 1,5	560 mm ²
Short-Circuit (Peak) (I _{pk})	25 kA
Short-Circuit (Peak) Tested 1 msec. (I _{cw})	12 kA
Resistance (R ₂₀)	0,192 mΩ/m
Reactance (X)	0,102 mΩ/m
Impedance (Z)	0,257 mΩ/m
Joule losses At I _n (I _{2r})	53,2 W/m

NAXSOPOWER/ER



NAXSOSANDWICH

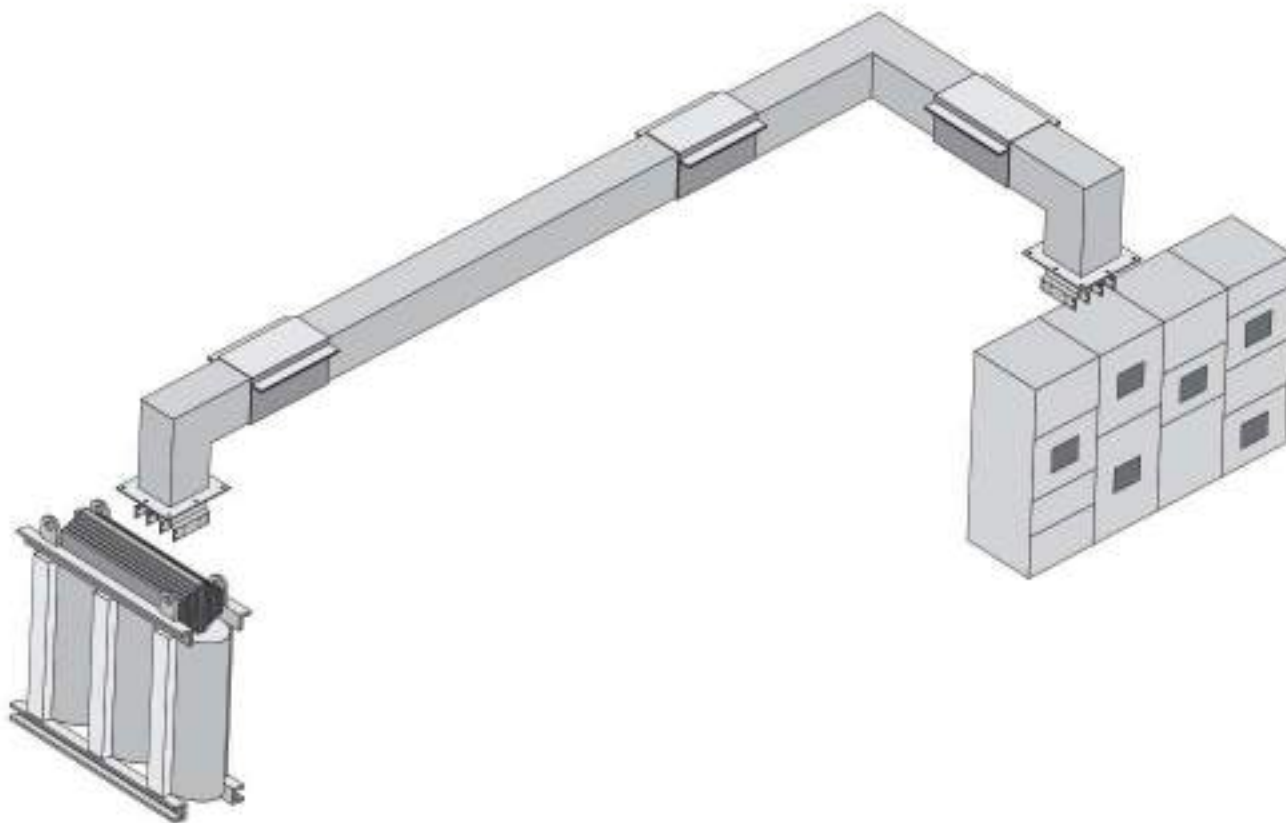

Naxso Sandwich is a modern busbar designed to guarantee high performances in a small dimension product. High performances are due to the design that is simple and easy and due to aluminum alloy that is 1050. Say the most pure in the range of extruded aluminium alloys and 13% better performing than the traditional 6060. All the housings are metal zinc galvanized and additionally painted so that the protection against aggressive climate and ambient conditions is very high and even electrical performances are assured by the mix of every pure aluminum and very low temperature and power dispersion due to design and housing painting. Two strong bolts in all the ratings up to 2000A and three bolts up to 4000A as well as five in 5000A make the joints to ensure a long life and constant pressure on all the conductors so that low maintenance is needed. When plug in is required a compact air busbar is made in the Naxso Sandwich range to give the right balance between ultracompact design in Feeder range and air compact to ensure good performance to all the tap offs installed and let an easy manufacturing of the busbar tap off up to 630A can be plugged along the busbar and up to 1000A on the joint.

Naxso Sandwich è una linea di condotti prefabbricati progettata per avere due principali caratteristiche, quali bassa impedenza e quindi alte prestazioni e notevole capacità di resistere al corto circuito e quindi a parità di amperaggio con altre serie di prodotti sul mercato garantisce alte prestazioni in dimensioni contenute.

Queste caratteristiche applicate ad una serie di prodotti di alto amperaggio si traducono in ridotte dimensioni, minimi pesi e massime prestazioni. Per prodotti di elevata potenza il vantaggio di essere semplici da installare e leggeri, conformemente alle potenze impiegate vuole dire costi molto contenuti e facilità di gestione del prodotto. Si pone l'accento sull'uso di alluminio di tipo lega 1050 come parte conduttori in quanto questa lega purissima è più performante della tradizionale lega 6060. Ha caratteristiche di conducibilità elettrica migliore del 13%, il che si traduce in migliori prestazioni e minori consumi per effetto joule, e minore dispersione e perdita di calore ed energia. I giunti sul prodotto sono dotati di due bulloni fino alla potenza di 2000A e di tre bulloni fino a 4000A, mentre il 5000A ha quattro bulloni. Ciò garantisce grande capacità di distribuzione di pressioni e quindi ottima ripartizione delle pressioni tra giunto e conduttori. Le carcasse metalliche della serie Naxso Sandwich sono in lamiera zincata e verniciata così come tutte le parti isolanti sono in classe B o superiore. Essendo il design semplice ed essenziale la realizzazione di lunghezze speciali fuori standard risulta veloce e semplice da realizzare. La grande gamma di possibili staffaggi offerta dalla Naxso per i suoi prodotti consente installazioni rapide, a tale fine si consiglia di sottoporre all'ufficio tecnico ogni sorta di problematica. In caso di richiesta di condotto tipo distribuzione Plug in la serie Air compact completa la gamma dando al prodotto il giusto bilanciamento tra le caratteristiche della distribuzione ultracompatta e i condotti atti alla distribuzione sacrificando parte delle caratteristiche di bassa impedenza a favore di un prodotto snello e performante in caso di installazione di spine lungo la tratta. Il Compact Air è veloce e leggero, facile da installare e consente l'inserimento di spine fino a 630 A lungo la tratta e di spine fino a 1000A sul giunto.



**ANGOLO DIEDRO
DIHEDRAL ELBOW
EDGEWISE ELBOW**

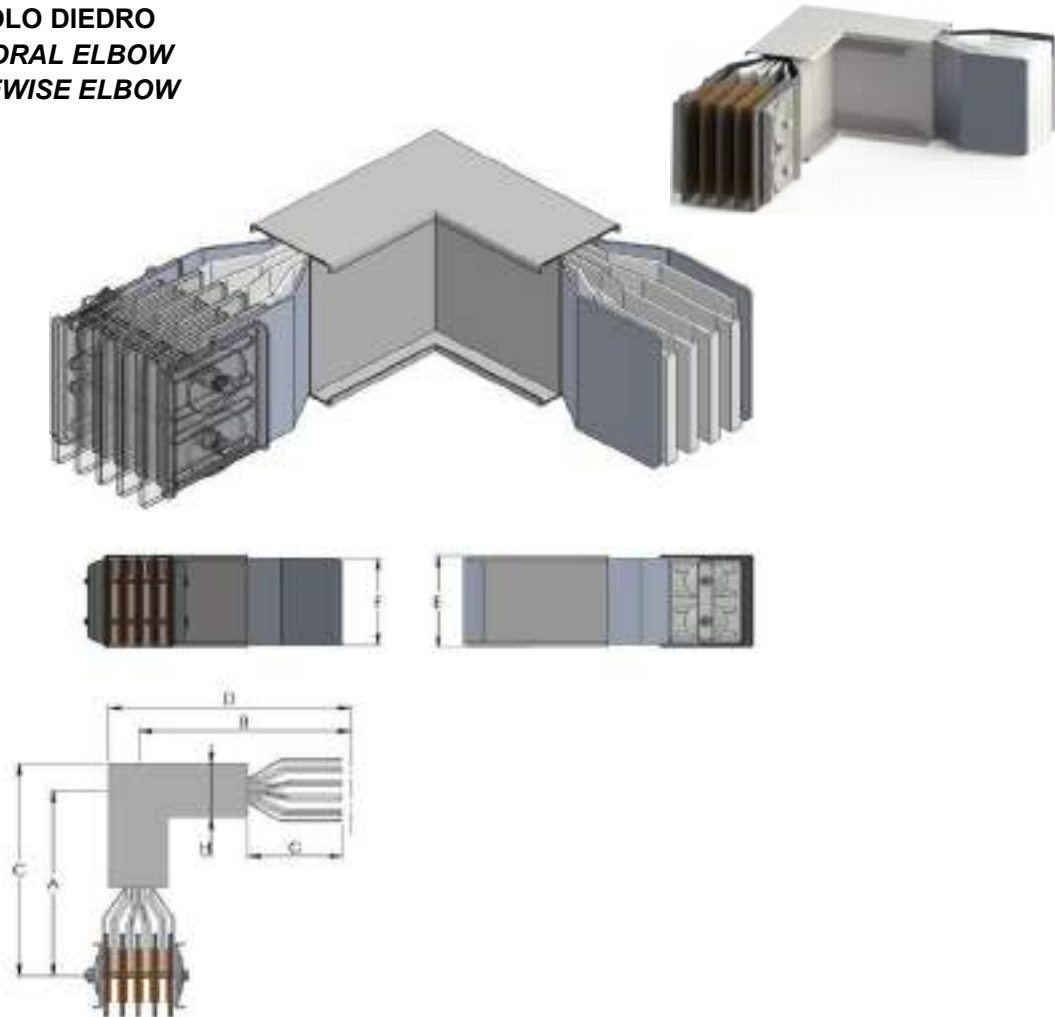

RANGE	DIMENSIONS (mm)								CODE
	A	B	C	D	E	F	G	H	
FEEDER - THICKNESS CONDUCTORS 5mm									
400 A	345	345	420	420	120	110	150	150	PXWCD400FE
630 A	345	345	420	420	120	110	150	150	PXWCD630FE
800 A	345	345	420	420	120	110	150	150	PXWCD800FE
1000 A	345	345	420	420	120	110	150	150	PXWCD1000FE
1250 A	345	345	420	420	190	180	150	150	PXWCD1250FE
1600 A	345	345	420	420	190	180	150	150	PXWCD1600FE
2000 A	345	345	420	420	250	240	150	150	PXWCD2000FE
2500 A	345	345	420	420	280	270	150	150	PXWCD2500FE
3200 A	345	345	420	420	410	400	150	150	PXWCD3200FE
4000 A	345	345	420	420	510	500	150	150	PXWCD4000FE
PLUG IN - THICKNESS CONDUCTORS 11,5mm									
400 A	345	345	420	420	120	110	150	150	PXWCD400PI
630 A	345	345	420	420	120	110	150	150	PXWCD630PI
800 A	345	345	420	420	120	110	150	150	PXWCD800PI
1000 A	345	345	420	420	120	110	150	150	PXWCD1000PI
1250 A	345	345	420	420	120	110	150	150	PXWCD1250PI
1600 A	345	345	420	420	170	155	150	150	PXWCD1600PI
2000 A	345	345	420	420	170	155	150	150	PXWCD2000PI
2500 A	345	345	420	420	170	155	150	150	PXWCD2500PI
3200 A	345	345	420	420	300	280	150	150	PXWCD3200PI
4000 A	345	345	420	420	300	280	150	150	PXWCD4000PI

NAXSOS/ANDP/IC/H



**ANGOLO PIANO
FLAT ELBOW
FLATWISE ELBOW**

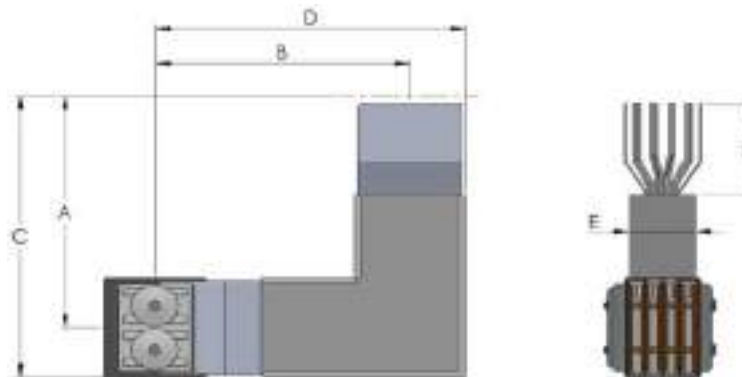
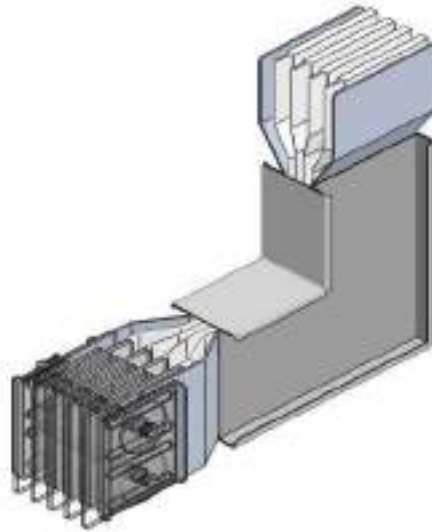

RANGE	DIMENSIONS (mm)						CODE
	A	B	C	D	E	F	
FEEDER - THICKNESS CONDUCTORS 5mm							
400 A	340	340	400	400	150	150	PXWCP400FE
630 A	340	340	400	400	150	150	PXWCP630FE
800 A	340	340	400	400	150	150	PXWCP800FE
1000 A	340	340	400	400	150	150	PXWCP1000FE
1250 A	375	375	470	470	150	150	PXWCP1250FE
1600 A	375	375	470	470	150	150	PXWCP1600FE
2000 A	405	405	530	530	150	150	PXWCP2000FE
2500 A	420	420	530	560	150	150	PXWCP2500FE
3200 A	485	485	690	690	150	150	PXWCP3200FE
4000 A	535	535	790	790	150	150	PXWCP4000FE
PLUG IN - THICKNESS CONDUCTORS 11,5mm							
400 A	340	340	400	400	150	150	PXWCP400PI
630 A	340	340	400	400	150	150	PXWCP630PI
800 A	340	340	400	400	150	150	PXWCP800PI
1000 A	340	340	400	400	150	150	PXWCP1000PI
1250 A	340	340	400	400	150	150	PXWCP1250PI
1600 A	365	365	450	450	150	150	PXWCP1600PI
2000 A	365	365	450	450	150	150	PXWCP2000PI
2500 A	365	365	450	450	150	150	PXWCP2500PI
3200 A	430	430	580	580	150	150	PXWCP3200PI
4000 A	430	430	580	580	150	150	PXWCP4000PI



ELEMENTO PER DISCESE AL QUADRO
SWITCHBOARD FEED ELEMENT
PANEL FLANGE

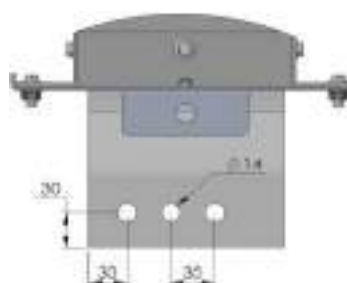
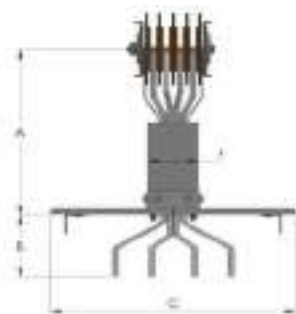
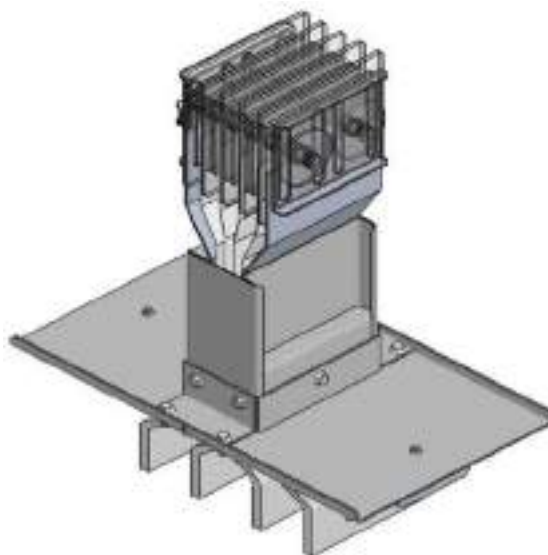

RANGE	DIMENSIONS (mm)						CODE
	A	B	C	D	E	F	
FEEDER - THICKNESS CONDUCTORS 5mm							
400 A	370	130	500	300	110	150	PXWAT400FE
630 A	370	130	500	300	110	150	PXWAT630FE
800 A	370	130	500	300	110	150	PXWAT800FE
1000 A	370	130	500	300	110	150	PXWAT1000FE
1250 A	370	130	500	300	180	150	PXWAT1250FE
1600 A	370	130	500	300	180	150	PXWAT1600FE
2000 A	370	130	500	400	240	150	PXWAT2000FE
2500 A	370	130	500	400	270	150	PXWAT2500FE
3200 A	370	130	500	550	400	150	PXWAT3200FE
4000 A	370	130	500	650	500	150	PXWAT4000FE
PLUG IN - THICKNESS CONDUCTORS 11,5mm							
400 A	370	130	500	300	110	150	PXWAT400PI
630 A	370	130	500	300	110	150	PXWAT630PI
800 A	370	130	500	300	110	150	PXWAT800PI
1000 A	370	130	500	300	110	150	PXWAT1000PI
1250 A	370	130	500	300	110	150	PXWAT1250PI
1600 A	370	130	500	300	155	150	PXWAT1600PI
2000 A	370	130	500	300	155	150	PXWAT2000PI
2500 A	370	130	500	300	155	150	PXWAT2500PI
3200 A	370	130	500	400	280	150	PXWAT3200PI
4000 A	370	130	500	400	280	150	PXWAT4000PI



PXW400FE

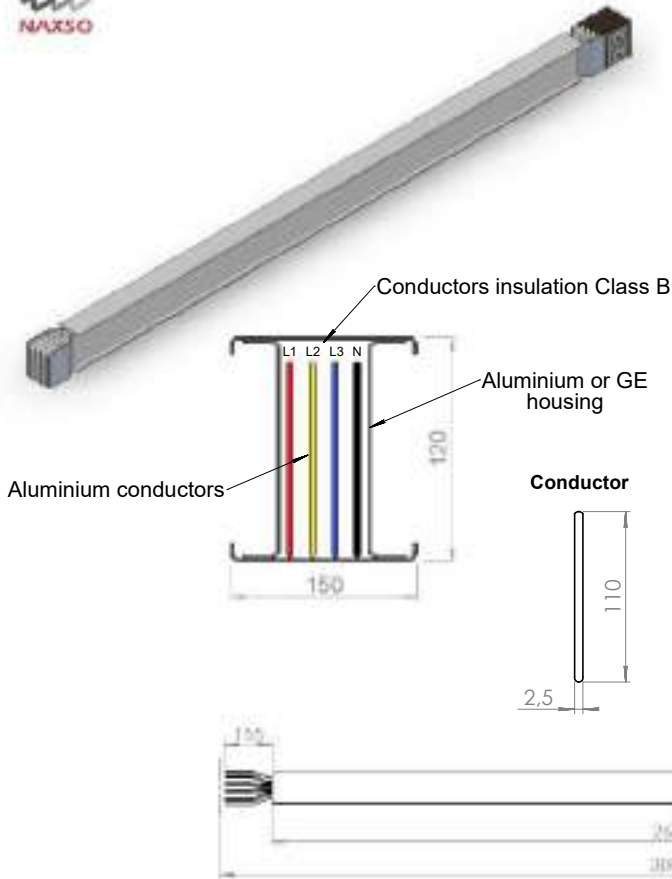

Rated Current	400A 4P AL
Housing	Aluminium / GE
Rated Insulation Voltage (Ui)	1000 V
Rated Operational Voltage (Ue)	1000 V
Rated frequency (f)	50/60 Hz
Protection Degree	IP20 (IP55 or IP68 optional)
Short-circuit (1 sec)(Icw)	50 kA
Dimension	150 X 120 mm
Area (PE) Housing cross section	850 mm ²
Thickness	1,5 mm
Perimetral	650 mm
Conductors N included	110 X 2,5 mm
Conductor cross section	270 mm ²
Conductors alloy	AL 1050
Conductor Insulation	Class B
Support polyester glass laminated	CTI >600
Supports temperature	Class B
Joint Insulation (polyester resin)	Class B



PXW400PI

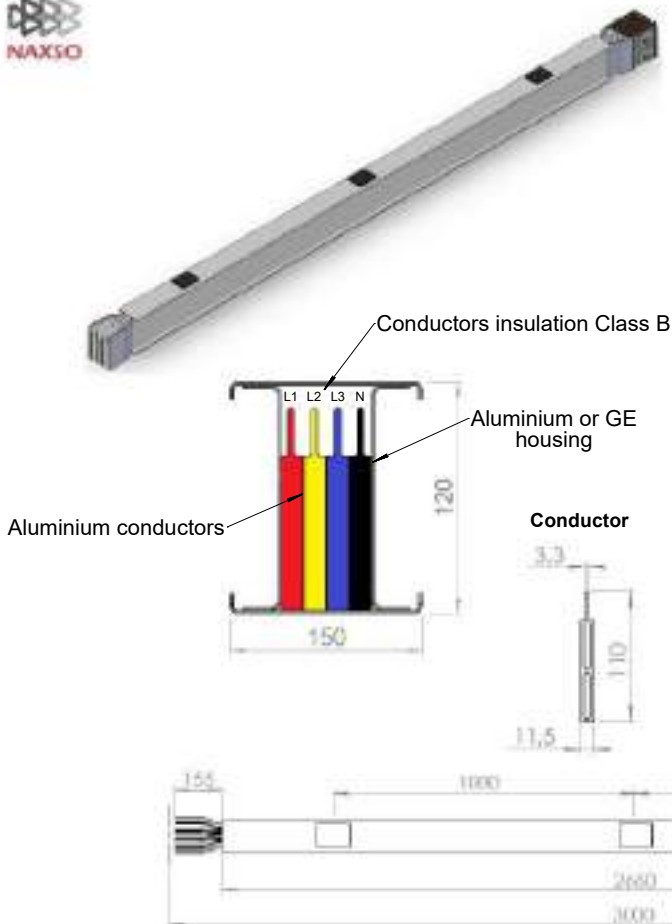

Rated Current	400A 4P AL
Housing	Aluminium / GE
Rated Insulation Voltage (Ui)	1000 V
Rated Operational Voltage (Ue)	1000 V
Rated frequency (f)	50/60 Hz
Protection Degree	IP20 (IP55 or IP68 optional)
Short-circuit (1 sec)(Icw)	50 kA
Dimension	150 X 120 mm
Area (PE) Housing cross section	850 mm ²
Thickness	1,5 mm
Perimetral	650 mm
Conductors N included	110 X 11,5 mm
Conductor cross section	450 mm ²
Conductors alloy	AL 1050
Conductor Insulation	Class B
Support polyester glass laminated	CTI >600
Supports temperature	Class B
Joint Insulation (polyester resin)	Class B
Windows (3) polyamide	Class B



PXW630FE

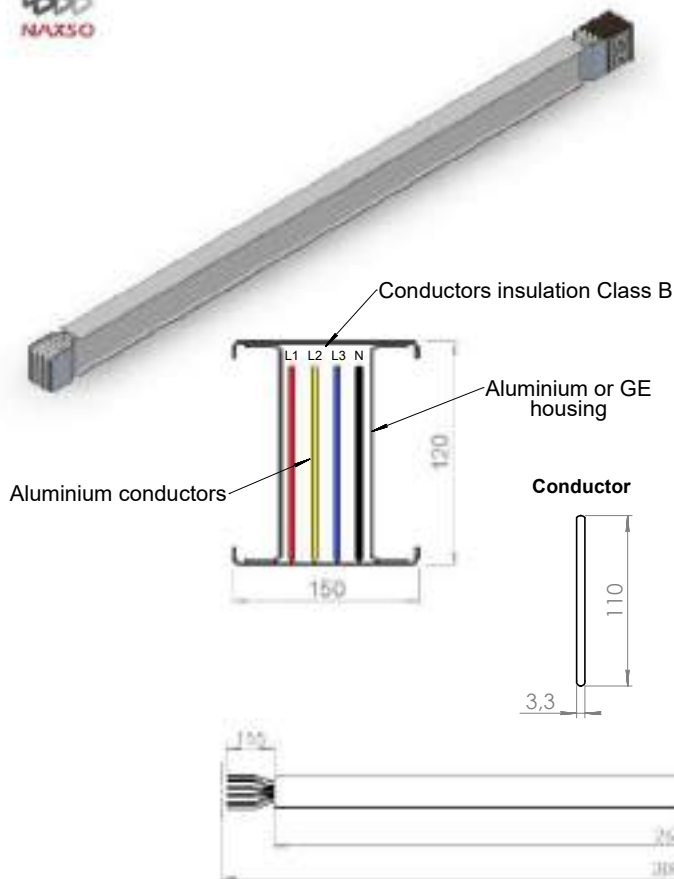

Rated Current	630A 4P AL
Housing	Aluminium / GE
Rated Insulation Voltage (Ui)	1000 V
Rated Operational Voltage (Ue)	1000 V
Rated frequency (f)	50/60 Hz
Protection Degree	IP20 (IP55 or IP68 optional)
Short-circuit (1 sec)(Icw)	50 kA
Dimension	150 X 120 mm
Area (PE) Housing cross section	850 mm ²
Thickness	1,5 mm
Perimetral	650 mm
Conductors N included	110 X 3,3 mm
Conductor cross section	365 mm ²
Conductors alloy	AL 1050
Conductor Insulation	Class B
Support polyester glass laminated	CTI >600
Supports temperature	Class B
Joint Insulation (polyester resin)	Class B



PXW630PI

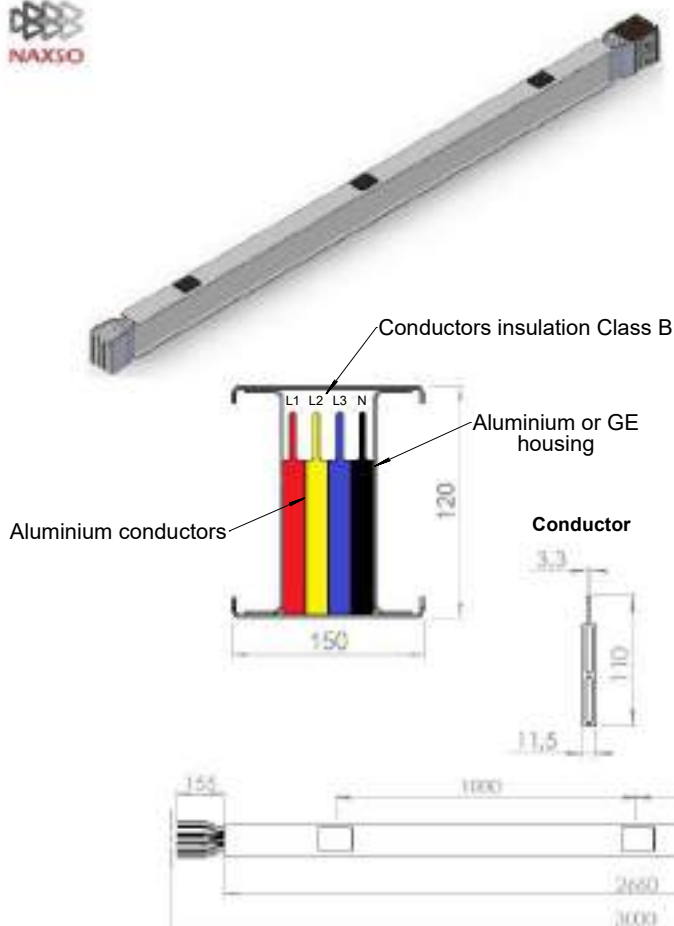

Rated Current	630A 4P AL
Housing	Aluminium / GE
Rated Insulation Voltage (Ui)	1000 V
Rated Operational Voltage (Ue)	1000 V
Rated frequency (f)	50/60 Hz
Protection Degree	IP20 (IP55 or IP68 optional)
Short-circuit (1 sec)(Icw)	50 kA
Dimension	150 X 120 mm
Area (PE) Housing cross section	850 mm ²
Thickness	1,5 mm
Perimetral	650 mm
Conductors N included	110 X 11,5 mm
Conductor cross section	450 mm ²
Conductors alloy	AL 1050
Conductor Insulation	Class B
Support polyester glass laminated	CTI >600
Supports temperature	Class B
Joint Insulation (polyester resin)	Class B
Windows (3) polyamide	Class B



PXW800FE

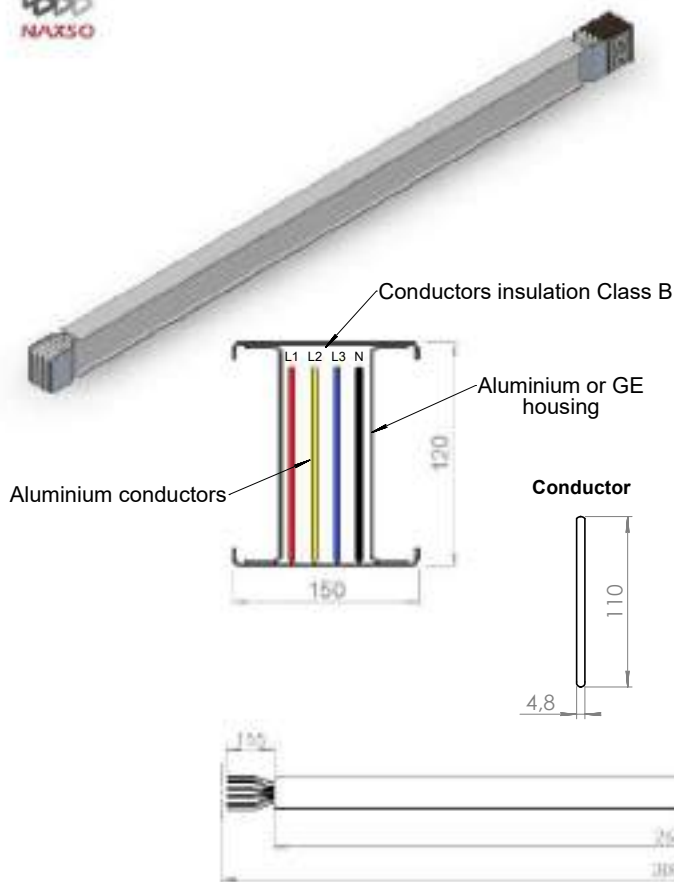

Rated Current	800A 4P AL
Housing	Aluminium / GE
Rated Insulation Voltage (Ui)	1000 V
Rated Operational Voltage (Ue)	1000 V
Rated frequency (f)	50/60 Hz
Protection Degree	IP20 (IP55 or IP68 optional)
Short-circuit (1 sec)(Icw)	50 kA
Dimension	150 X 120 mm
Area (PE) Housing cross section	850 mm ²
Thickness	1,5 mm
Perimetral	650 mm
Conductors N included	110 X 4,8 mm
Conductor cross section	528 mm ²
Conductors alloy	AL 1050
Conductor Insulation	Class B
Support polyester glass laminated	CTI >600
Supports temperature	Class B
Joint Insulation (polyester resin)	Class B



PXW800PI

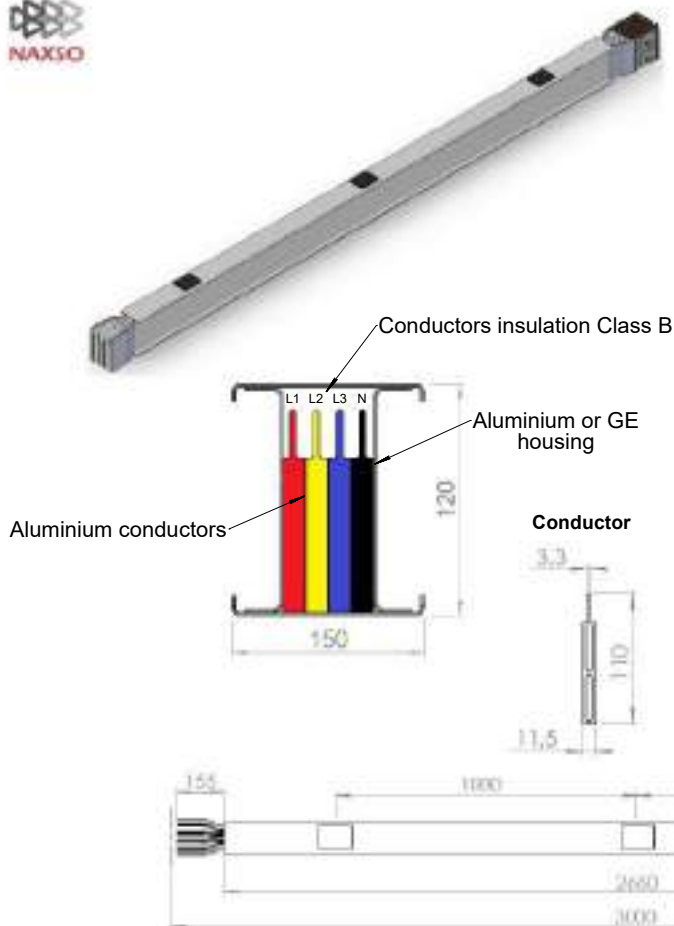

Rated Current	800A 4P AL
Housing	Aluminium / GE
Rated Insulation Voltage (Ui)	1000 V
Rated Operational Voltage (Ue)	1000 V
Rated frequency (f)	50/60 Hz
Protection Degree	IP20 (IP55 or IP68 optional)
Short-circuit (1 sec)(Icw)	50 kA
Dimension	150 X 120 mm
Area (PE) Housing cross section	850 mm ²
Thickness	1,5 mm
Perimetral	650 mm
Conductors N included	110 X 11,5 mm
Conductor cross section	650 mm ²
Conductors alloy	AL 1050
Conductor Insulation	Class B
Support polyester glass laminated	CTI >600
Supports temperature	Class B
Joint Insulation (polyester resin)	Class B
Windows (3) polyamide	Class B



PXW1000FE

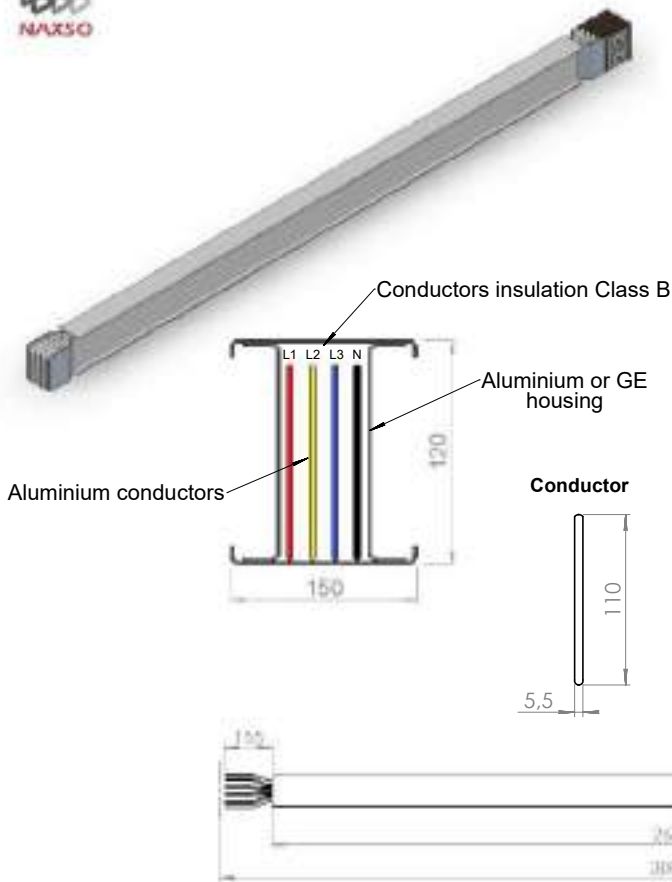

Rated Current	1000A 4P AL
Housing	Aluminium / GE
Rated Insulation Voltage (Ui)	1000 V
Rated Operational Voltage (Ue)	1000 V
Rated frequency (f)	50/60 Hz
Protection Degree	IP20 (IP55 or IP68 optional)
Short-circuit (1 sec)(Icw)	50 kA
Dimension	150 X 120 mm
Area (PE) Housing cross section	850 mm ²
Thickness	1,5 mm
Perimetral	650 mm
Conductors N included	110 X 5,5 mm
Conductor cross section	605 mm ²
Conductors alloy	AL 1050
Conductor Insulation	Class B
Support polyester glass laminated	CTI >600
Supports temperature	Class B
Joint Insulation (polyester resin)	Class B



PXW1000PI

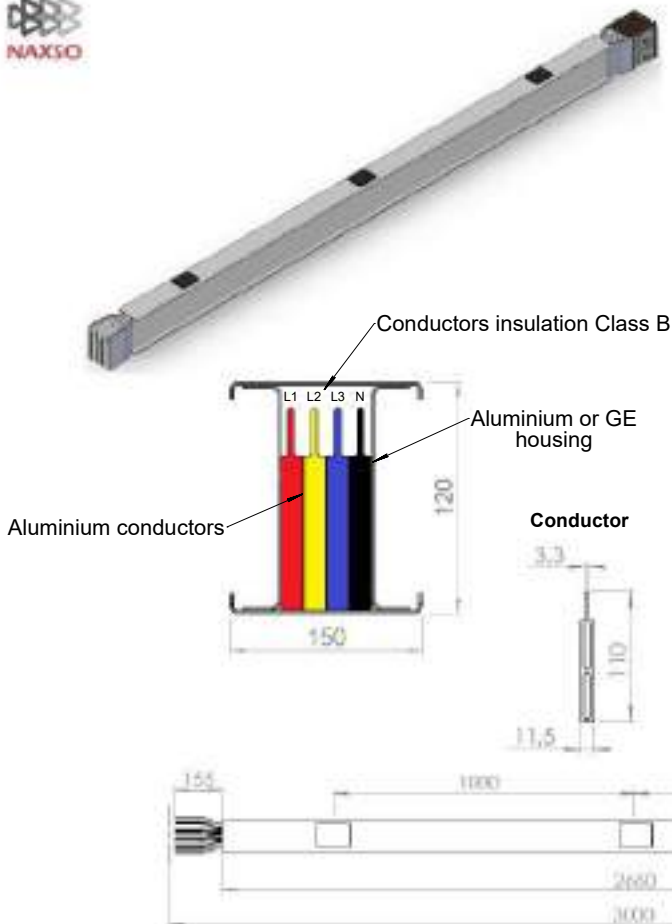

Rated Current	1000A 4P AL
Housing	Aluminium / GE
Rated Insulation Voltage (Ui)	1000 V
Rated Operational Voltage (Ue)	1000 V
Rated frequency (f)	50/60 Hz
Protection Degree	IP20 (IP55 or IP68 optional)
Short-circuit (1 sec)(Icw)	50 kA
Dimension	150 X 120 mm
Area (PE) Housing cross section	850 mm ²
Thickness	1,5 mm
Perimetral	650 mm
Conductors N included	110 X 11,5 mm
Conductor cross section	900 mm ²
Conductors alloy	AL 1050
Conductor Insulation	Class B
Support polyester glass laminated	CTI >600
Supports temperature	Class B
Joint Insulation (polyester resin)	Class B
Windows (3) polyamide	Class B



PXW1250FE

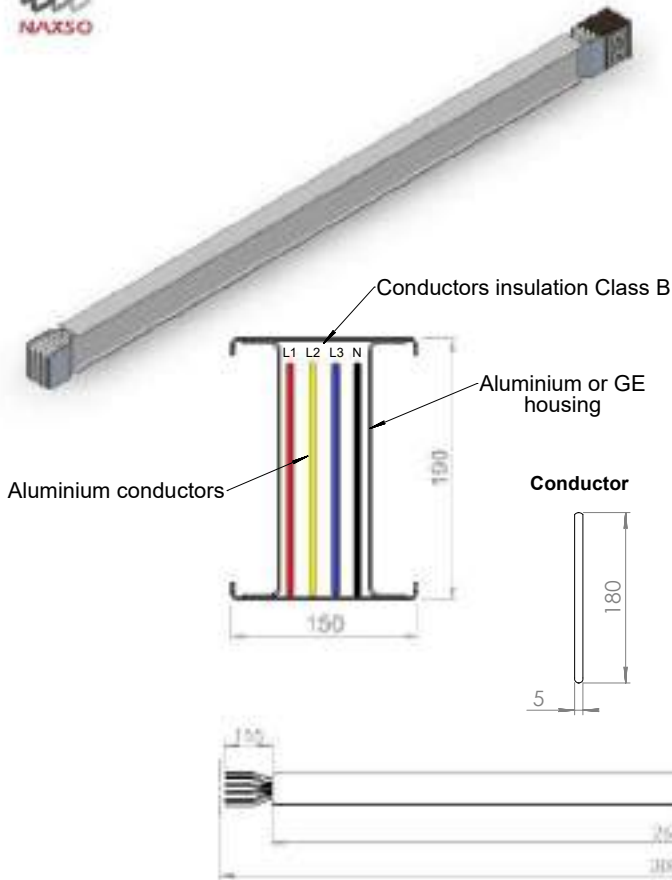

Rated Current	1250A 4P AL
Housing	Aluminium / GE
Rated Insulation Voltage (Ui)	1000 V
Rated Operational Voltage (Ue)	1000 V
Rated frequency (f)	50/60 Hz
Protection Degree	IP20 (IP55 or IP68 optional)
Short-circuit (1 sec)(Icw)	50 kA
Dimension	150 X 190 mm
Area (PE) Housing cross section	1100 mm ²
Thickness	1,5 mm
Perimetral	780 mm
Conductors N included	180 X 5 mm
Conductor cross section	895 mm ²
Conductors alloy	AL 1050
Conductor Insulation	Class B
Support polyester glass laminated	CTI >600
Supports temperature	Class B
Joint Insulation (polyester resin)	Class B



PXW1250PI

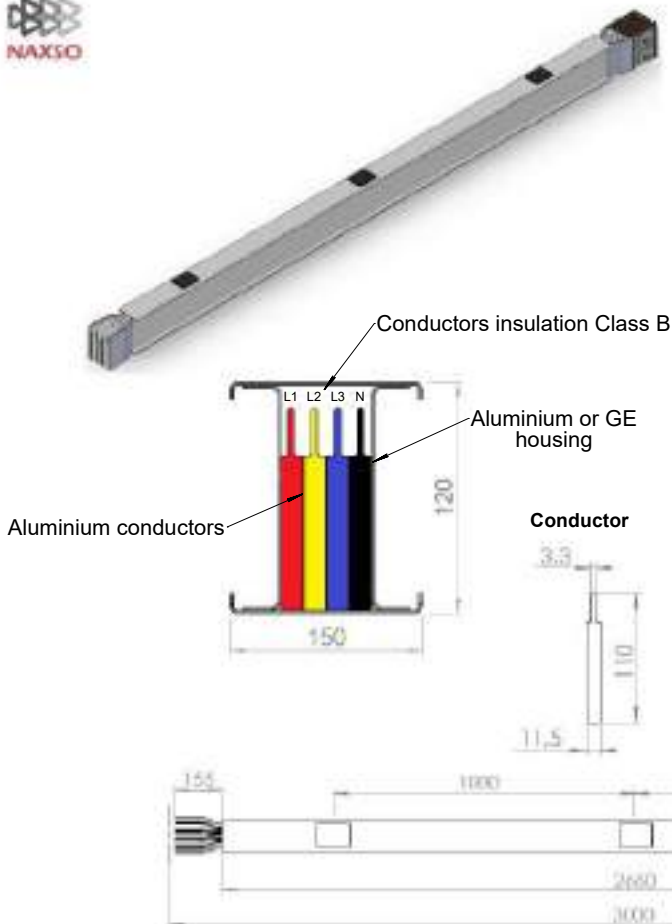

Rated Current	1250A 4P AL
Housing	Aluminium / GE
Rated Insulation Voltage (Ui)	1000 V
Rated Operational Voltage (Ue)	1000 V
Rated frequency (f)	50/60 Hz
Protection Degree	IP20 (IP55 or IP68 optional)
Short-circuit (1 sec)(Icw)	50 kA
Dimension	150 X 120 mm
Area (PE) Housing cross section	850 mm ²
Thickness	1,5 mm
Perimetral	650 mm
Conductors N included	110 X 11,5 mm
Conductor cross section	1000 mm ²
Conductors alloy	AL 1050
Conductor Insulation	Class B
Support polyester glass laminated	CTI >600
Supports temperature	Class B
Joint Insulation (polyester resin)	Class B
Windows (3) polyamide	Class B



PXW1600FE

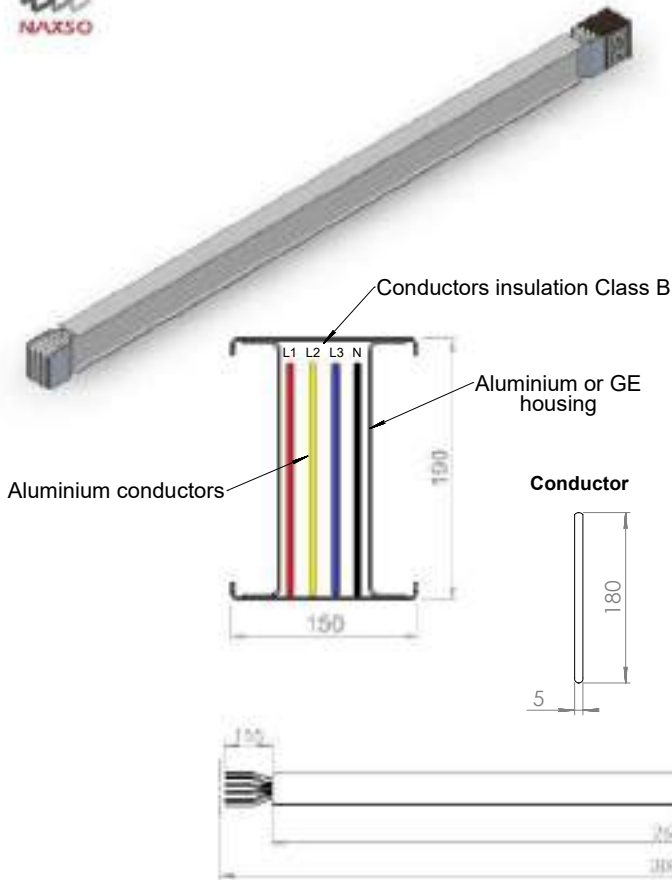

Rated Current	1600A 4P AL
Housing	Aluminium / GE
Rated Insulation Voltage (Ui)	1000 V
Rated Operational Voltage (Ue)	1000 V
Rated frequency (f)	50/60 Hz
Protection Degree	IP20 (IP55 or IP68 optional)
Short-circuit (1 sec)(Icw)	80 kA
Dimension	150 X 190 mm
Area (PE) Housing cross section	1100 mm ²
Thickness	1,5 mm
Perimetral	780 mm
Conductors N included	180 X 5 mm
Conductor cross section	895 mm ²
Conductors alloy	AL 1050
Conductor Insulation	Class B
Support polyester glass laminated	CTI >600
Supports temperature	Class B
Joint Insulation (polyester resin)	Class B



PXW1600PI

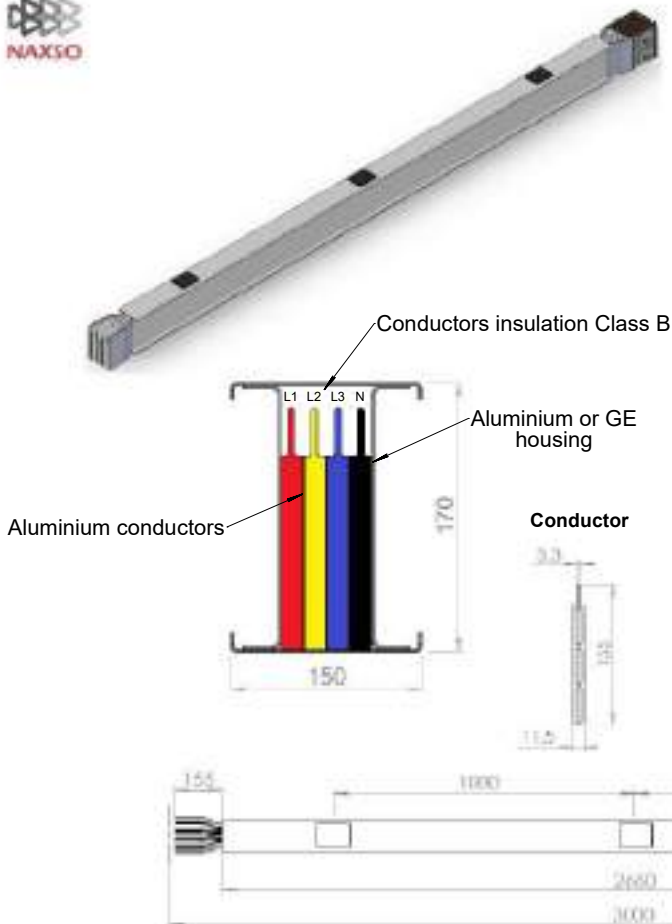

Rated Current	1600A 4P AL
Housing	Aluminium / GE
Rated Insulation Voltage (Ui)	1000 V
Rated Operational Voltage (Ue)	1000 V
Rated frequency (f)	50/60 Hz
Protection Degree	IP20 (IP55 or IP68 optional)
Short-circuit (1 sec)(Icw)	80 kA
Dimension	150 X 170 mm
Area (PE) Housing cross section	1000 mm ²
Thickness	1,5 mm
Perimetral	750 mm
Conductors N included	155 X 11,5 mm
Conductor cross section	1100 mm ²
Conductors alloy	AL 1050
Conductor Insulation	Class B
Support polyester glass laminated	CTI >600
Supports temperature	Class B
Joint Insulation (polyester resin)	Class B
Windows (3) polyamide	Class B



PXW2000FE

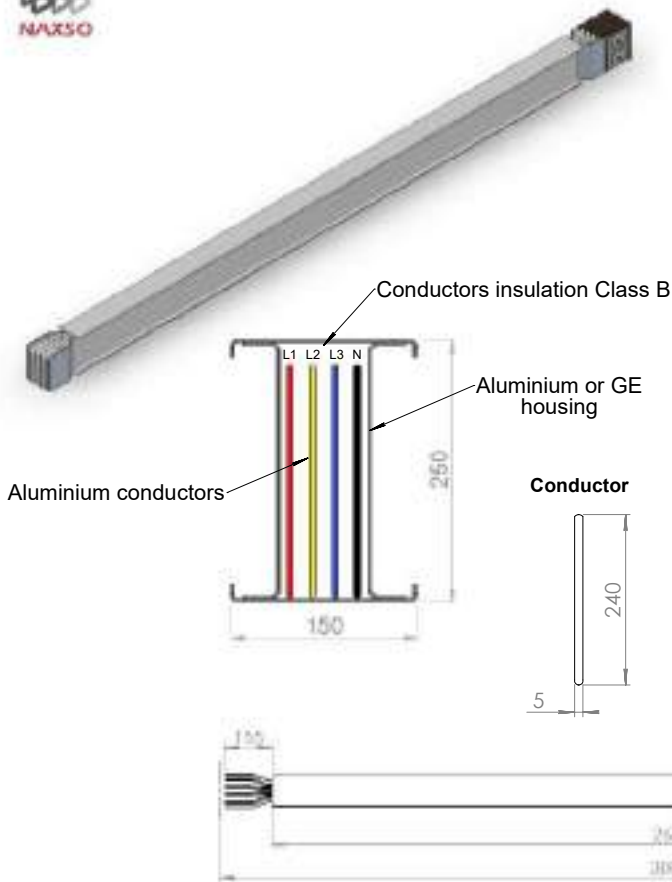

Rated Current	2000A 4P AL
Housing	Aluminium / GE
Rated Insulation Voltage (Ui)	1000 V
Rated Operational Voltage (Ue)	1000 V
Rated frequency (f)	50/60 Hz
Protection Degree	IP20 (IP55 or IP68 optional)
Short-circuit (1 sec)(Icw)	80 kA
Dimension	150 X 250 mm
Area (PE) Housing cross section	1250 mm ²
Thickness	1,5 mm
Perimetral	900 mm
Conductors N included	240 X 5 mm
Conductor cross section	1195 mm ²
Conductors alloy	AL 1050
Conductor Insulation	Class B
Support polyester glass laminated	CTI >600
Supports temperature	Class B
Joint Insulation (polyester resin)	Class B



PXW2000PI

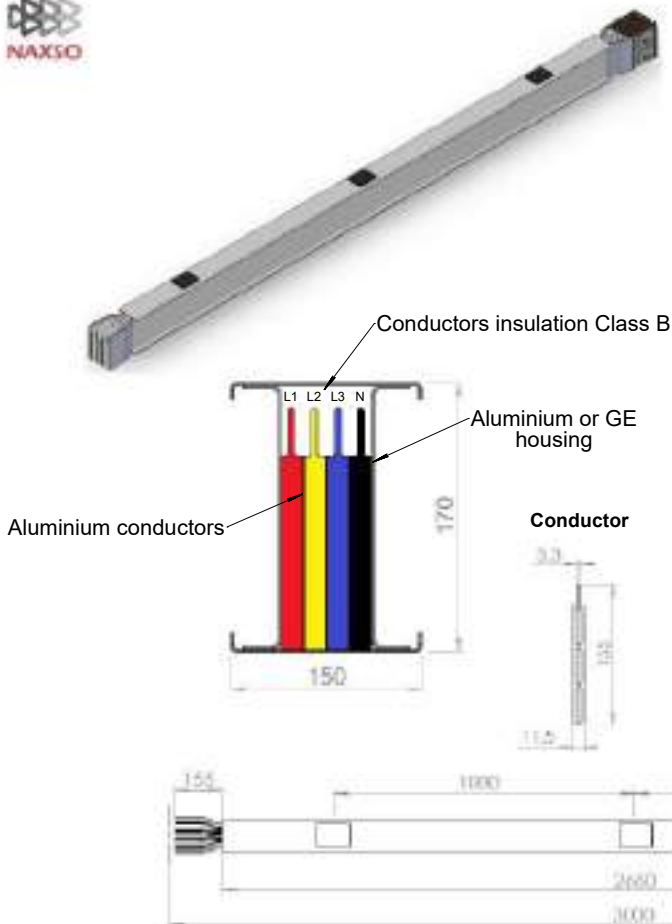

Rated Current	2000A 4P AL
Housing	Aluminium / GE
Rated Insulation Voltage (Ui)	1000 V
Rated Operational Voltage (Ue)	1000 V
Rated frequency (f)	50/60 Hz
Protection Degree	IP20 (IP55 or IP68 optional)
Short-circuit (1 sec)(Icw)	80 kA
Dimension	150 X 170 mm
Area (PE) Housing cross section	1000 mm ²
Thickness	1,5 mm
Perimetral	750 mm
Conductors N included	155 X 11,5 mm
Conductor cross section	1570 mm ²
Conductors alloy	AL 1050
Conductor Insulation	Class B
Support polyester glass laminated	CTI >600
Supports temperature	Class B
Joint Insulation (polyester resin)	Class B
Windows (3) polyamide	Class B

NAXSOS/ANDX/ICH



PXW2500FE

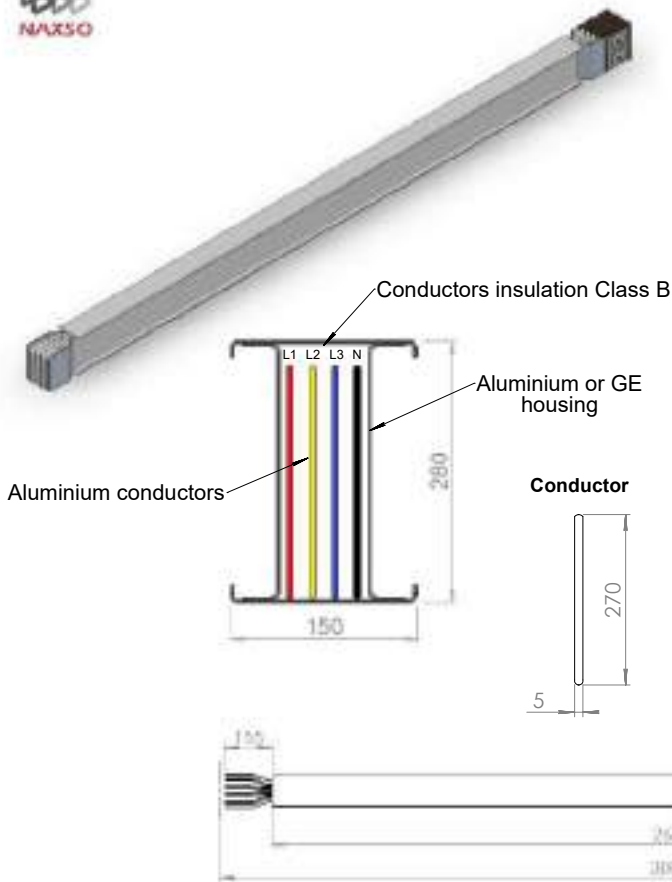

Rated Current	2500A 4P AL
Housing	Aluminium / GE
Rated Insulation Voltage (Ui)	1000 V
Rated Operational Voltage (Ue)	1000 V
Rated frequency (f)	50/60 Hz
Protection Degree	IP20 (IP55 or IP68 optional)
Short-circuit (1 sec)(Icw)	80 kA
Dimension	150 X 280 mm
Area (PE) Housing cross section	1320 mm ²
Thickness	1,5 mm
Perimetral	960 mm
Conductors N included	270 X 5 mm
Conductor cross section	1345 mm ²
Conductors alloy	AL 1050
Conductor Insulation	Class B
Support polyester glass laminated	CTI >600
Supports temperature	Class B
Joint Insulation (polyester resin)	Class B



PXW2500PI

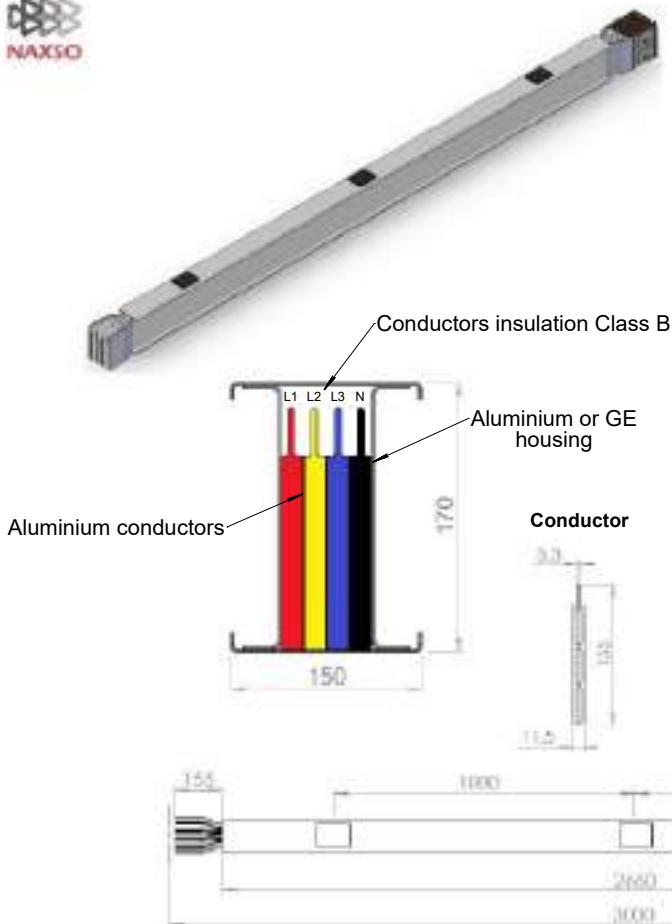

Rated Current	2500A 4P AL
Housing	Aluminium / GE
Rated Insulation Voltage (Ui)	1000 V
Rated Operational Voltage (Ue)	1000 V
Rated frequency (f)	50/60 Hz
Protection Degree	IP20 (IP55 or IP68 optional)
Short-circuit (1 sec)(Icw)	80 kA
Dimension	150 X 170 mm
Area (PE) Housing cross section	1000 mm ²
Thickness	1,5 mm
Perimetral	750 mm
Conductors N included	155 X 11,5 mm
Conductor cross section	1570 mm ²
Conductors alloy	AL 1050
Conductor Insulation	Class B
Support polyester glass laminated	CTI >600
Supports temperature	Class B
Joint Insulation (polyester resin)	Class B
Windows (3) polyamide	Class B



PXW3200FE

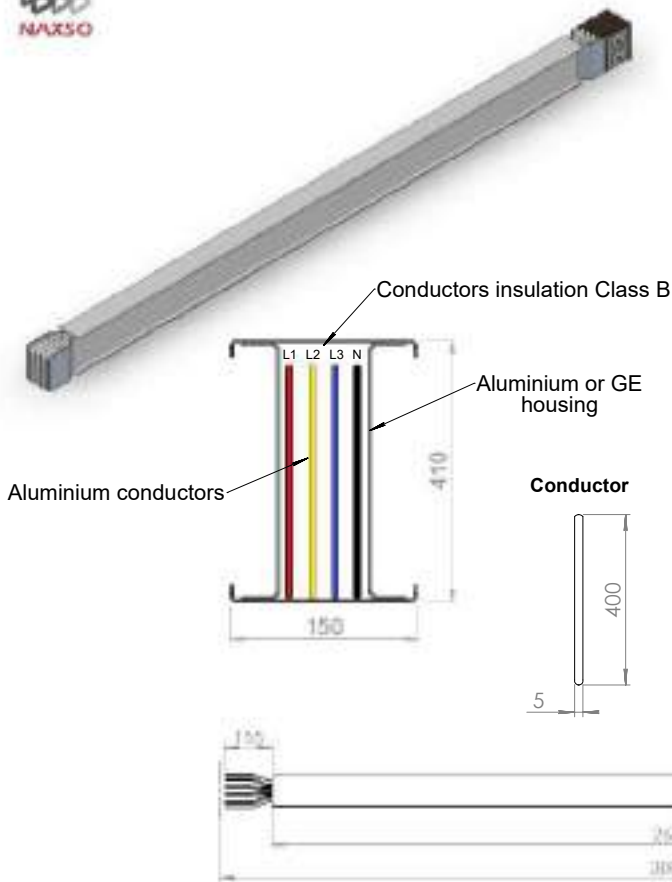

Rated Current	3200A 4P AL
Housing	Aluminium / GE
Rated Insulation Voltage (Ui)	1000 V
Rated Operational Voltage (Ue)	1000 V
Rated frequency (f)	50/60 Hz
Protection Degree	IP20 (IP55 or IP68 optional)
Short-circuit (1 sec)(Icw)	80 kA
Dimension	150 X 410 mm
Area (PE) Housing cross section	1700 mm ²
Thickness	1,5 mm
Perimetral	1220 mm
Conductors N included	400 X 5 mm
Conductor cross section	1995 mm ²
Conductors alloy	AL 1050
Conductor Insulation	Class B
Support polyester glass laminated	CTI >600
Supports temperature	Class B
Joint Insulation (polyester resin)	Class B



PXW3200PI

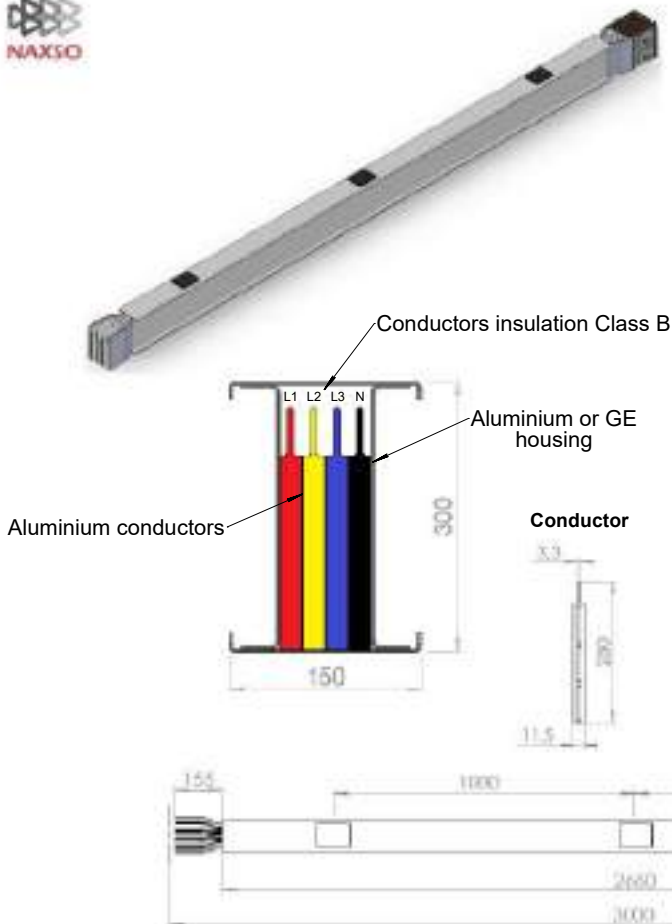

Rated Current	3200A 4P AL
Housing	Aluminium / GE
Rated Insulation Voltage (Ui)	1000 V
Rated Operational Voltage (Ue)	1000 V
Rated frequency (f)	50/60 Hz
Protection Degree	IP20 (IP55 or IP68 optional)
Short-circuit (1 sec)(Icw)	80 kA
Dimension	150 X 300 mm
Area (PE) Housing cross section	1400 mm ²
Thickness	1,5 mm
Perimetral	1000 mm
Conductors N included	280 X 11,5 mm
Conductor cross section	2500 mm ²
Conductors alloy	AL 1050
Conductor Insulation	Class B
Support polyester glass laminated	CTI >600
Supports temperature	Class B
Joint Insulation (polyester resin)	Class B
Windows (3) polyamide	Class B



PXW4000FE

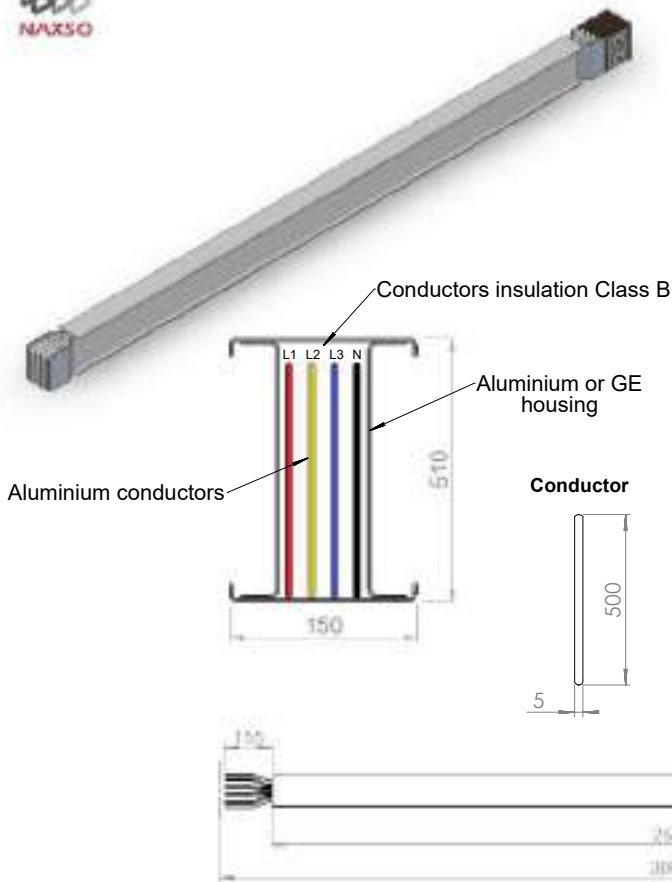

Rated Current	4000A 4P AL
Housing	Aluminium / GE
Rated Insulation Voltage (Ui)	1000 V
Rated Operational Voltage (Ue)	1000 V
Rated frequency (f)	50/60 Hz
Protection Degree	IP20 (IP55 or IP68 optional)
Short-circuit (1 sec)(Icw)	80 kA
Dimension	150 X 510 mm
Area (PE) Housing cross section	2000 mm ²
Thickness	1,5 mm
Perimetral	1420 mm
Conductors N included	500 X 5 mm
Conductor cross section	2495 mm ²
Conductors alloy	AL 1050
Conductor Insulation	Class B
Support polyester glass laminated	CTI >600
Supports temperature	Class B
Joint Insulation (polyester resin)	Class B



PXW4000PI

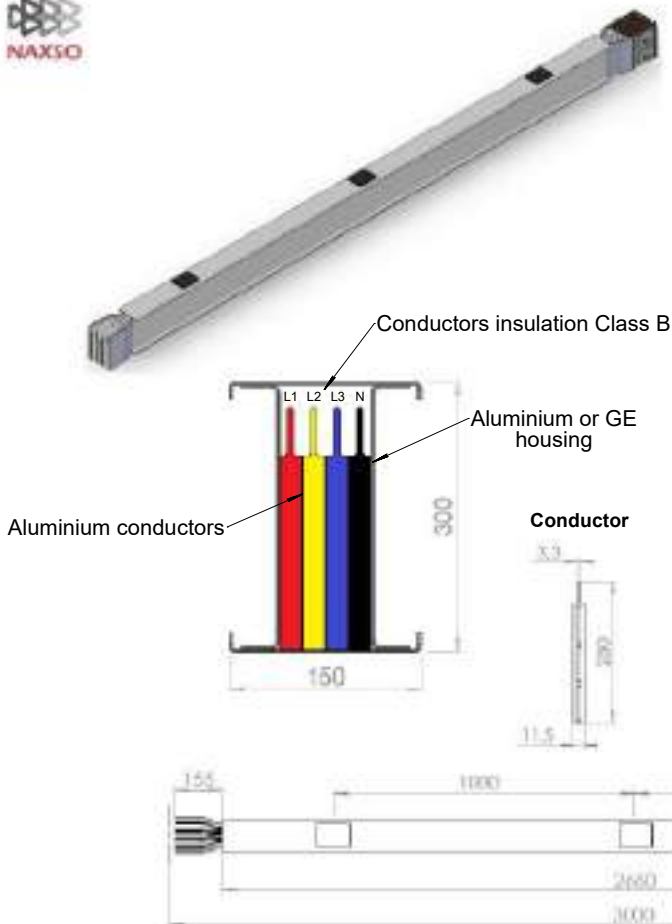

Rated Current	4000A 4P AL
Housing	Aluminium / GE
Rated Insulation Voltage (Ui)	1000 V
Rated Operational Voltage (Ue)	1000 V
Rated frequency (f)	50/60 Hz
Protection Degree	IP20 (IP55 or IP68 optional)
Short-circuit (1 sec)(Icw)	80 kA
Dimension	150 X 300 mm
Area (PE) Housing cross section	1400 mm ²
Thickness	1,5 mm
Perimetral	1000 mm
Conductors N included	280 X 11,5 mm
Conductor cross section	2800 mm ²
Conductors alloy	AL 1050
Conductor Insulation	Class B
Support polyester glass laminated	CTI >600
Supports temperature	Class B
Joint Insulation (polyester resin)	Class B
Windows (3) polyamide	Class B

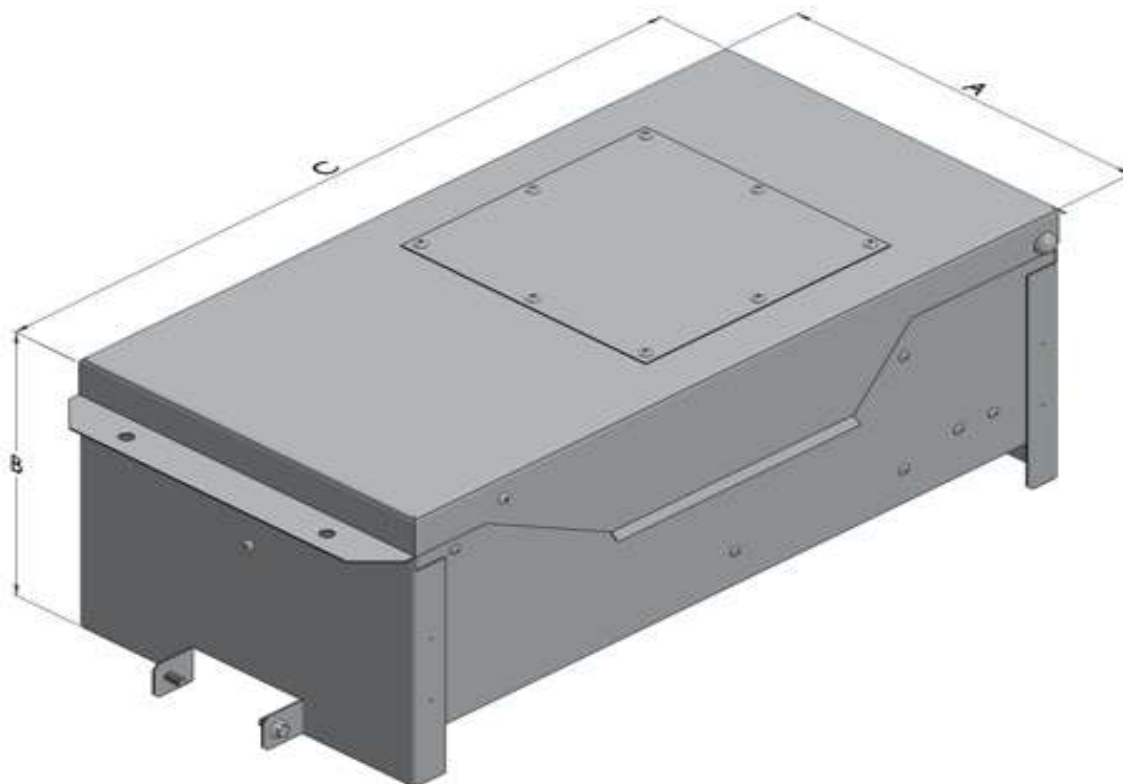

**CASSETTA DI DERIVAZIONE
TAP-OFF BOX**

ATTENTION: NOT USE ABSOLUTLY CIRCUIT BREAKER CHINESE MCB OR MCCB

RANGE	DIMENSIONS (mm)			CODE
	A	B	C	
50 A	240	160	460	STAR50PXW
100 A	240	160	460	STAR100PXW
160 A	240	160	460	STAR160PXW
250 A	300	200	700	STAR250DMPXW
400 A	300	200	700	STAR400DMPXW
630 A	300	200	700	STAR630DMPXWJ
800 A	300	200	700	STAR800DMPXWJ
1000 A	300	200	700	STAR1000DMPXWJ

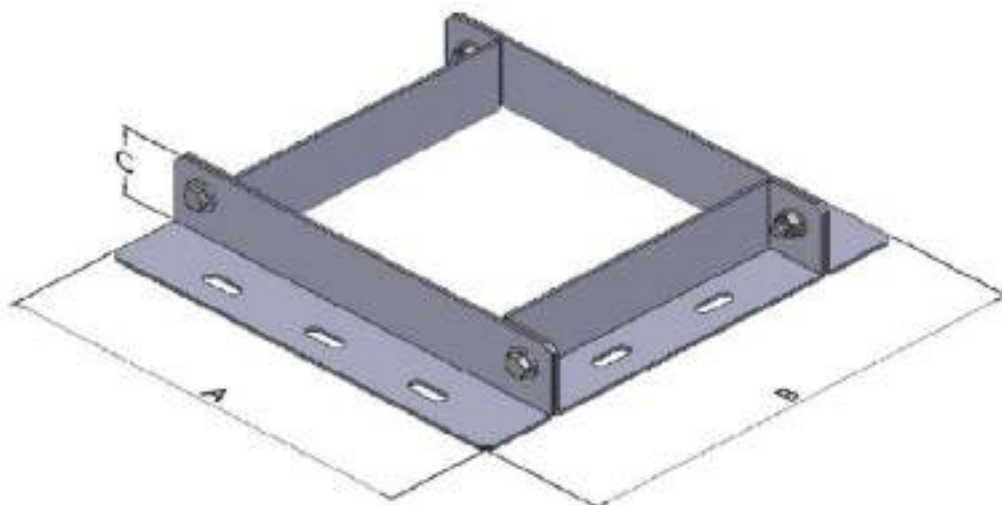

**STAFFE DI SOSPENSIONE
HANGER**



ON REQUEST

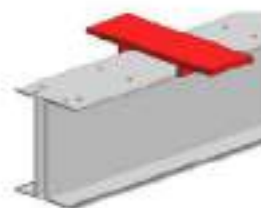

RANGE	DIMENSIONS (mm)			CODE
	A	B	C	
<i>1250 A</i>	210	270	50	PXWATST1250
<i>1600 A</i>	210	270	50	PXWATST1600
<i>2000 A</i>	210	270	50	PXWATST2000
<i>2500 A</i>	210	440	50	PXWATST2500
<i>3200 A</i>	210	440	50	PXWATST3200
<i>4000 A</i>	210	440	50	PXWATST4000
<i>5000 A</i>	210	610	50	PXWATST5000



STAFFE PER ELEMENTI IN VERTICALE
VERTICAL HANGER

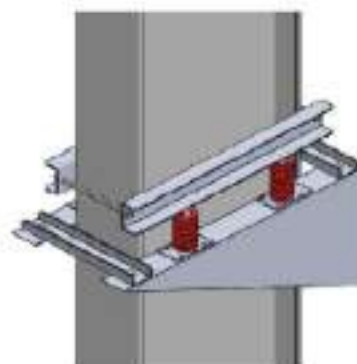
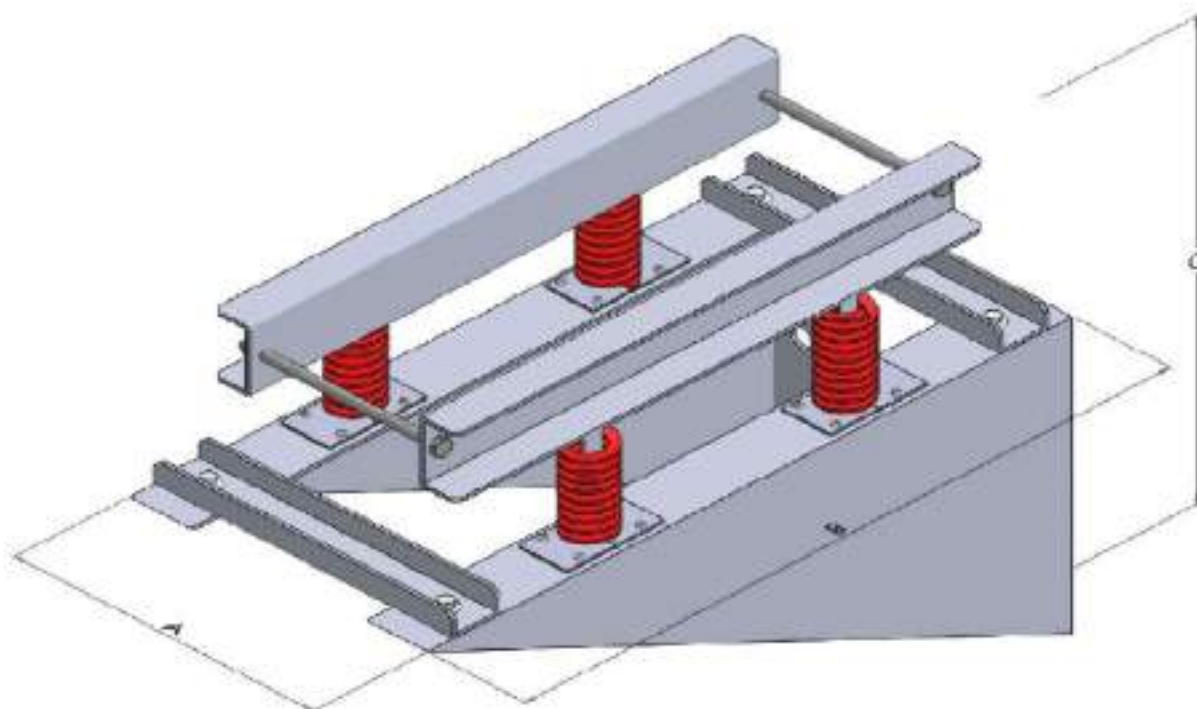

RANGE	DIMENSIONS (mm)			CODE
	A	B	C	
1250 A	220	300	450	PXWVB1250
1600 A	220	300	450	PXWVB1600
2000 A	220	300	450	PXWVB2000
2500 A	220	480	450	PXWVB2500
3200 A	220	480	450	PXWVB3200
4000 A	220	480	450	PXWVB4000
5000 A	220	650	450	PXWVB5000



BARRIERA TAGLIAFUOCO
FIRE BARRIER

Dimensioni a richiesta

Dimensions on request

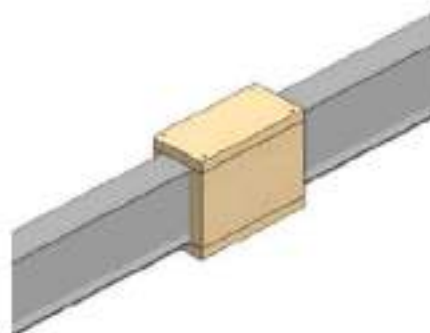
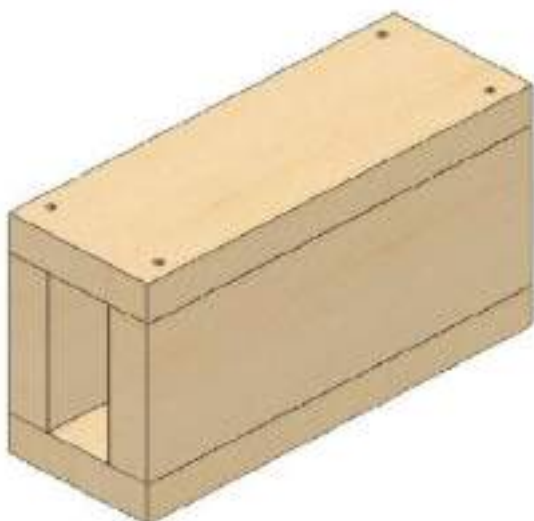

ACCESSORIO PROTEZIONE DI COPERTURA
ADDITIONAL PROTECTIVE CANOPY

Dimensioni a richiesta

Dimensions on request

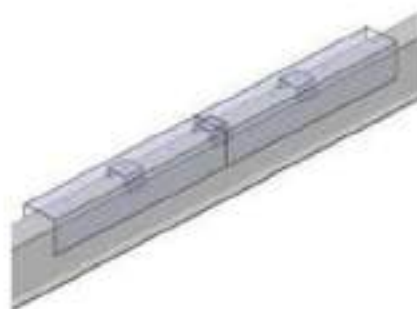
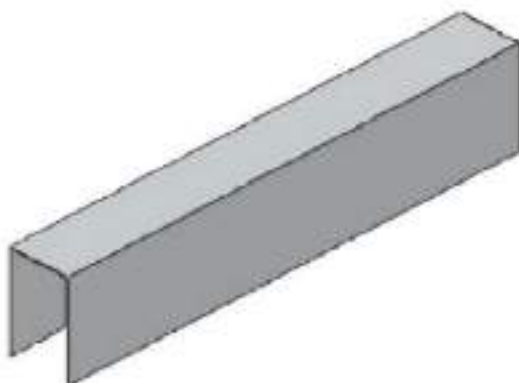



CONFIGURAZIONE PER DISCESE AL QUADRO
SWITCHBOARD FEED ELEMENT CONFIGURATION
PANEL FLANGE CONFIGURATION

VERSIONE STANDARD
STANDARD VERSION

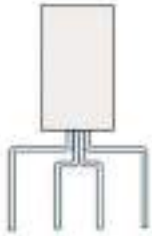

SPECIALE 1
SPECIAL 1



SPECIALE 2
SPECIAL 2

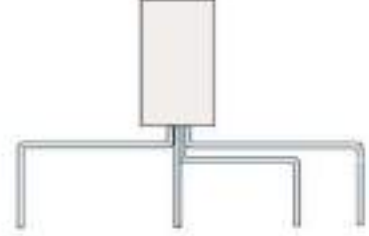

SPECIALE 3
SPECIAL 3

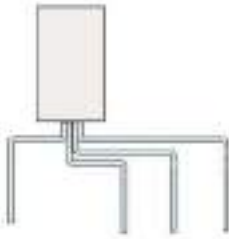

SPECIALE 4
SPECIAL 4



SPECIALE 5
SPECIAL 5

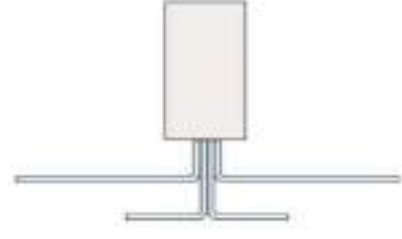

CONNESSIONI VERSO I TRASFORMATORI
TRANSFORMER CONNECTIONS

Dimensioni e portata a richiesta

Dimensions and rated current on request

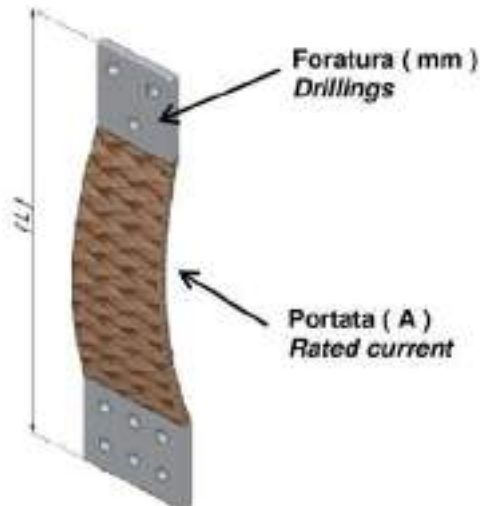

Bandelle flessibili per la connessione al trasformatore realizzate in trecce di rame.

Flexible braids for transformer connection. They are manufactured in Copper.

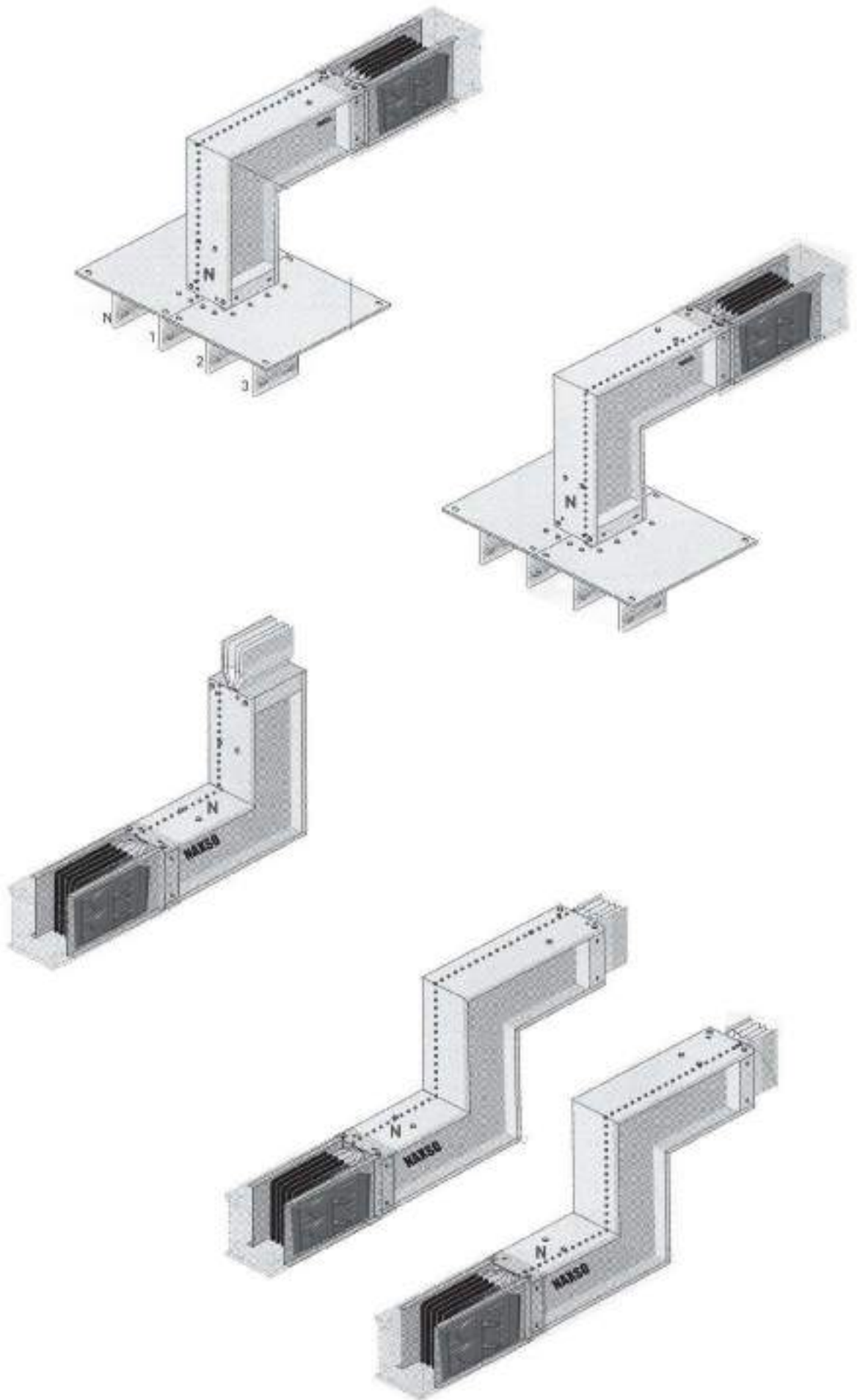

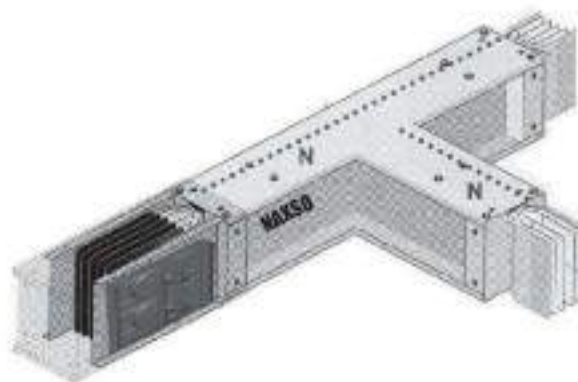
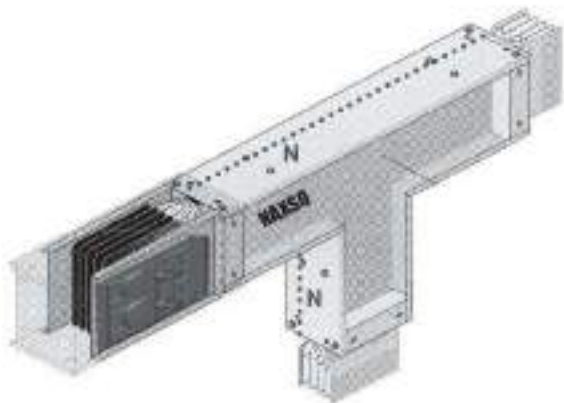
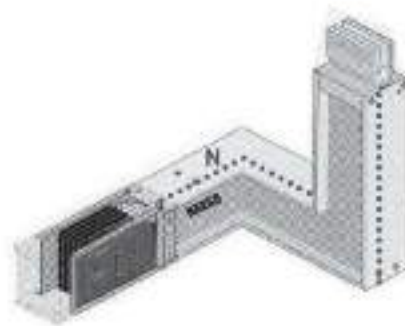
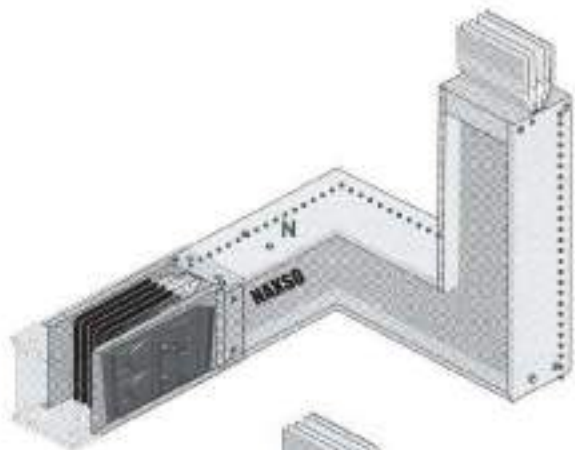
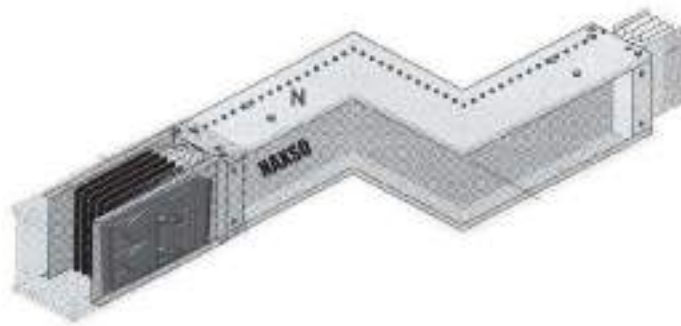

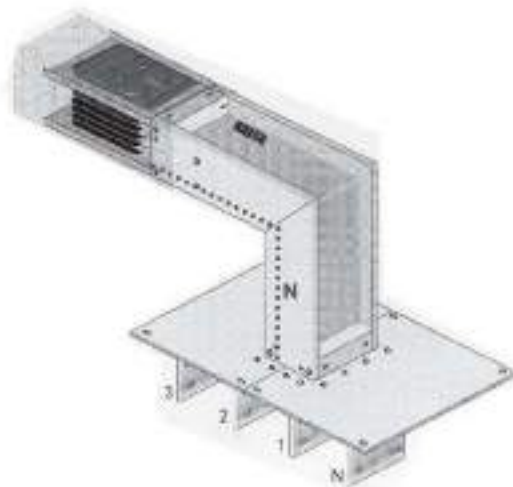
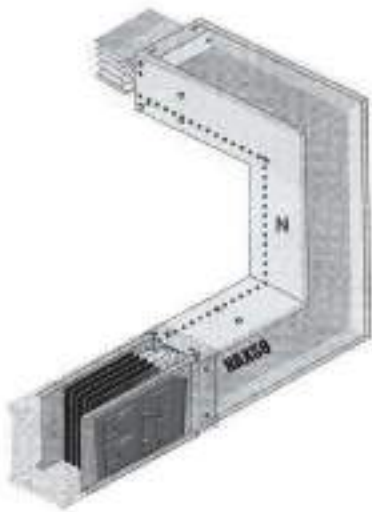

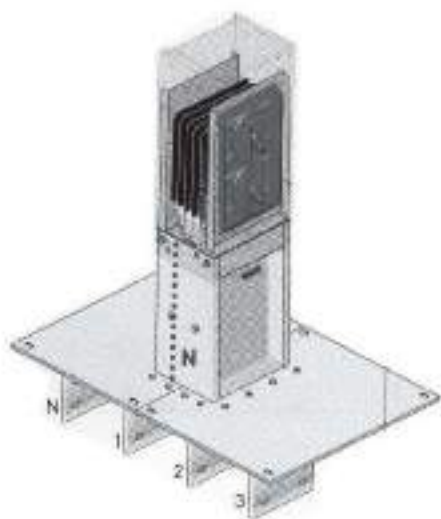
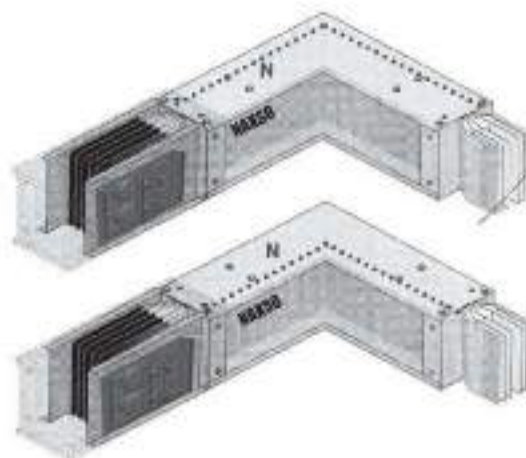

NAXSOS/ANDX/ICH

TAB A - POLYAMIDE 66 GLASS FILLED 30% - POLIAMMIDE 66 FIBRA VETRO 30%			
PROPERTY PROPRIETA'	METHODS METODI	UNITS UNITA'	VALUES VALORI
DENSITY / DENSITA'	ASTM D792	Mg/mc	1,50
Reinforcing material <i>Contenuto di carica/rinforzo</i>	Internal / Interno	%	50
Mould shrinkage <i>Ritiro lineare allo stampaggio</i>	ASTM D955	%	0,10 - 0,25
Water absorption <i>Assorbimento d'acqua 24h a 23°C</i>	ASTM D570	%	0,5
MECHANICAL / MECCANICHE			
Elongation break <i>Allungamento a rottura</i>	ASTM D638	%	2
Flexural modulus	ASTM D790	N/mm ²	1500
Impact strength <i>Izod-Urti con intaglio</i>	ASTM D256	J/m	150
Flex strenght	ASTM D790	N/mm ²	300
Textile yield <i>Carico di snervamento a trazione</i>	ASTM D638	Mn/m ²	220
Rockwell hardness <i>Durezza rockwell</i>	ASTM D785	scala R	122
Textile yield	ASTM D790	Mn/m ²	315
THERMAL / TERMICHE			
Melting temperature <i>Temperatura di fusione</i>	ASTM D792	°C	258 2
Softening point <i>Punto di rammollimento VICAT</i>	ASTM D1525	°C	255
	MN/m ² 0,45	ASTM D648	°C
	MN/m ² 1,81	ASTM D648	°C
ELECTRICAL / ELETTRICHE			
Glow wire	IEC 695-2-1	°C	850
Flame reactivity	Second / Secondo U.L.94	#3,2	Uo

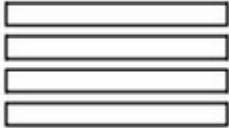
Derating chart							
	T1	T2	P	V	E	J1	J2
1000 A	5%	10%	5%	5%	/	/	5
1250 A	5%	10%	5%	5%	/	/	5
1600 A	5%	10%	5%	3%	2	/	5
2000 A	5%	15%	5%	3%	2	2	5
2500 A	5%	15%	5%	3%	2	3	5
3200 A	5%	15%	5%	3%	2	5	7
4000 A	5%	15%	7%	3%	2	5	10
T1 ambient temperature higher than 35°							
T2 more than 45°							
P position flat							
V vertical installation							
E each elbow derating							
J1 joints more than 30 line > 90 mt							
J2 joints more than 50 line > 150 mt							

TAB B - POLYPROPYLENE GLASS FILLED 30% NATURAL - POLIPOPRILENE FIBRA VETRO 30% NATURALE

PROPERTY PROPRIETA'	METHODS METODI		UNITS UNITA'	VALUES VALORI
Melt index <i>Indice di fusione</i>	ASTM D1238		gr/10	7
Moisture content <i>Umidità</i>	ISO 15512C		%	
Volume <i>Massa volumica</i>	Internal / Interno		gr/cm ³	1,14
Powder ashes <i>Ceneri 30/750 °C</i>	Internal / Interno		%	29,5
Resistance <i>Resistenza Izod con intaglio</i>	+23 °C	ASTN D256	J/m	72
	0° C	ASTN D256	J/m	
	-20 °C	ASTN D256	J/m	
Reduction <i>Ritiro lineare allo stampaggio</i>	Internal / Interno		%	
Melting point <i>Punto di rammolimento VICAT</i>	9,8 N	ASTN M1525	°C	105
	49 N	ASTN M1525	°C	
Temperature of deflexion under stress <i>Temperatura di deflessione sotto carico</i>	46 N/cm ²	ASTM D648	°C	
	1,82 N/mm ²	ASTM D648	°C	

TAB E - ALUMINIUM - ALLUMINIO EN AW-A199.5 UNI EN 573-3 (1050A)

PROPERTY PROPRIETA'	UNITS UNITA'	VALUES VALORI
Peso specifico	Kg/dm ³	2,7
Modulo di elasticità	N/mm ²	68600
Modulo di rigidità	N/mm ²	26500
Punto di fusione	°C	658
Calore specifico 0 - 100 °C	cal/g °C ⁻¹	0,22
Coefficiente di dilatazione teorico lineare 20 - 100	24 x 10 ⁻⁶ x K ⁻¹	
Conducibilità termica 20 °C	(s x cm x °C)	0,5 cal
Resistance at 20 °C (T6) Resistenza a 20 °C (T6)	μ Ω x cm	2,83 ÷ 2,90

CHEMICAL COMPOSITION PERCENTAGE *COMPOSIZIONE CHIMICA PERCENTUALE*

Si	Fe	Cu	Mn	Mg	Zn	Ti	Other impurity <i>Altre impunità</i>	AL
0,25	0,40	0,05	0,05	0,05	0,07	0,05	0,03	99,5

BARRA ESTRUSA

Stato metallurgico	Dimensioni (mm)		Carico di rottura a trazione		Carico al limite snervamento		Allungamento	
	D ¹⁾	S ²⁾	Min.	Max.	Min.	Max.	Min.	Min.
F ⁴⁾ , H112	tutte	tutte	60 R ^m MPa	-	20 R ^{p0,2} MPa	-	25 A%	23 A ^{50mm%}
O, H111	tutte	tutte	60 R ^m MPa	95 R ^m MPa	20 R ^{p0,2} MPa	-	25 A%	23 A ^{50mm%}

TUBO ESTRUSO

Stato metallurgico	Dimensioni (mm)		Carico di rottura a trazione		Carico al limite snervamento		Allungamento	
	D ¹⁾	S ²⁾	Min.	Max.	Min.	Max.	Min.	Min.
F ⁴⁾ , H112	tutte	tutte	60 R ^m MPa	-	20 R ^{p0,2} MPa	-	25 A%	23 A ^{50mm%}
O, H111	tutte	tutte	60 R ^m MPa	95 R ^m MPa	20 R ^{p0,2} MPa	-	25 A%	23 A ^{50mm%}

TUBO ESTRUSO

Stato metallurgico	Dimensioni (mm)		carico di rottura a trazione		Carico al limite snervamento		Allungamento	
	D ¹⁾	S ²⁾	Min.	Max.	Min.	Max.	Min.	Min.
F ⁴⁾ , H112	tutte	tutte	60 R ^m MPa	-	20 R ^{p0,2} MPa	-	25 A%	23 A ^{50mm%}

IMQ Test Report nr. 01FB00263

PRODUCT DEPARTMENT Page: 1 of 3
 LABORATORY REGULATORY PROCEDURES AND ASSOCIATED FORMS DATE: 2009/06/22

MEASUREMENT OF FORCE NEEDED TO PULL OUT THE CABLE FROM PLUG TYPE MOUSE

Number of samples under test: 3
 Test operating mode:
 - The cable has been connected to the fix end of dynamometer while the plug to the mobile end of same apparatus.
 - A traction force, with 50 mm/sec speed, is applied to the plug until the disjunction of cable occurs.

Test Apparatus: Dynamometer INSTRON type 4301 - IMQ_ID: P.00470
 Test Configuration: See Figure

Test Results: The disjunction of electric cable from mouse plug has happened as soon as the force was got the value of 40 Kg.

IMQ Test Report nr. 01FB00263

PRODUCT DEPARTMENT Page: 2 of 3
 LABORATORY REGULATORY PROCEDURES AND ASSOCIATED FORMS DATE: 2009/06/22

MEASUREMENT OF FORCE NEEDED TO PULL OUT THE CABLE FROM RECTILINEAR BUSBAR

Number of samples under test: 3
 Test operating mode:
 - The Aluminum rectilinear busbar has been connected to the fix end of dynamometer while the plug to the mobile end of same apparatus.
 - A traction force, with 50 mm/sec speed, is applied to the plug until the disjunction of cable occurs.
 - The assembly of security spring (among plug) clips has been intentionally oxidized.

Test Apparatus: Dynamometer INSTRON type 4301 - IMQ_ID: P.00470
 Test Configuration: See Figure

Test Results: The disjunction of electric cable from bar has happened as soon as force was got the value of 30 Kg. The breakage of one of the clips is occurred.

IMQ Test Report nr. 01FB00263

PRODUCT DEPARTMENT Page: 1 of 3
 LABORATORY REGULATORY PROCEDURES AND ASSOCIATED FORMS DATE: 2009/06/22

MEASUREMENT OF FORCE NEEDED TO PULL OUT THE PLUG FROM RECTILINEAR BUSBAR

Number of samples under test: 3
 Test operating mode:
 - The Aluminum rectilinear busbar has been connected to the fix end of dynamometer while the plug to the mobile end of same apparatus.
 - A traction force, with 50 mm/sec speed, is applied to the plug until the disjunction of cable occurs.
 - During this test, the plug has been connected to bar, as requested from manufacturer, by a security spring placed among plug clips.

Test Apparatus: Dynamometer INSTRON type 4301 - IMQ_ID: P.00470
 Test Configuration: See Figure

Test Results: The disjunction of plug from bar has happened as soon as the force was got the value of 30 Kg due to breakage of two clips and disjunction of security spring.

IMQ Test Report nr. 01SB00114

PRODUCT DEPARTMENT Page: 1 of 4
 LABORATORY REGULATORY PROCEDURES AND ASSOCIATED FORMS DATE: 2009/06/22

Product	Aluminum cable busbar with and without protective coating
Model type	-
Description	Sample in standard plate Sample in aluminum of rectangular section Sample in aluminum oxidized of rectangular section
Applicant	NAXSO S.p.A. - Via Quindici, 41 - 20138 TORINO
Manufacturer	NAXSO S.p.A. - Via Quindici, 41 - 20138 TORINO
Test carried out by	W/D S.p.A. - Laboratorio CNV/Coat s.r.l. sede stessa Via Quindici, 43 - 20138 Milano
Scope of the test	- To assess the resistance to the corrosion in salt mist atmosphere
Date of samples receiving	2022/05
Date of tests start	2022/07/11
Date of tests end	2022/03/27
This test report is composed by	4 pages, divided as follows: 4 report pages
Cable Testing Lab Technician	Cable Testing Lab Head

The results referred in this report are only relevant to the samples tested and described in this report. Only complete reproduction of this report is permitted. A false use is the authentication of IMQ.

IMQ S.p.A. - Via Quindici 41 - 20138 MILANO



Misty test is provided to compare different kind of surface protections. The test is runned putting in the same humid and salty room for 96 hours different materials and at the end a visual check is required to describe the results. It is possible to see how the standard aluminium can stand the humidity with some little rusty stains as well as the anodized one is strong and excellent when the housing is under hard conditions and at the end how standard steel even if galvanized have a very poor resistance against humidity.

La prova suddetta dimostra la resistenza del prodotto all'aggressione derivante dalla esposizione alla umidità in un clima salino corrosivo per una durata di 96 ore (primo ciclo) e 288 ore (secondo ciclo). Dopo questi test i prodotti non devono presentare danneggiamenti significativi.

Dalla foto riportata dal test eseguito presso l'IMQ si vede il risultato comparativo, come previsto dalla norma, tra un campione di materiale sendzimir, un campione di alluminio standard NAXSOLUX ed uno anodizzato.

Il campione in metallo dopo la prova è completamente corrosivo mentre quello in alluminio standard è appena intaccato da macchie superficiali ed infine quello in alluminio anodizzato è risultato completamente indifferente all'aggressione della nebbia salina.

DECLARATION OF EC CONFORMITY

DICHIARAZIONE DI CONFORMITÀ

No. TL/Prot20209

The product / Prodotto**Type reference / Sigla prodotto**Naxsolux 25A - 40A - 63A
Serie BA**Supplier / Fornitore**

Naxso Srl 10135 TORINO (I)

Description / Descrizione:**Light Busbar trunking system**
Condotta barre prefabbricate**To which this declaration relates is in conformity with the following standard:***L'oggetto di questa dichiarazione è conforme ai seguenti standard o normative:***Standard / Norme:**CEI 17/13-1-2
CEI EN 61439
CEI EN 61000-2-4 (CEI 110-27)
DIN VDE 0660 parte 500-502
CEI EN 60068-2-11:2000 Class
CEI 104-17-F.5890**Type tests / Prove di Tipo**

1. Temperature-rise limits
2. Dielectric properties
3. Short-circuit strength
4. Effectiveness of the protective circuit
5. Clearances and creepage distances
6. Mechanical operation
7. Degree of protection
8. Electrical characteristics
9. Structural strength
10. Crushing resistance
11. Resistance to flame propagation
12. Fire barrier in building penetration

1. Tenuta alla tensione applicata
2. Limiti di sovratemperatura
3. Efficienza del circuito di protezione
4. Tenuta al cortocircuito
5. Cablaggio, funzionamento elettrico
6. Grado di protezione
7. Funzionamento
8. Distanze in aria e superficiali
9. Isolamento
10. Resistenza di isolamento
11. Misure di protezione
12. Barriera tagliafuoco

Date of issue / Data
12/05/2015

NAXSO S.r.l.

DECLARATION OF EC CONFORMITY
DICHIARAZIONE DI CONFORMITÀ

No. TL/Prot20210

The product / Prodotto**Type reference / Sigla prodotto**Naxsopower BP 40A - 63A - 100A - 160A
Naxsopower BPG 250A - 400A - 630A**Supplier / Fornitore**

Naxso Srl 10135 TORINO (I)

Description / Descrizione**Light Busbar trunking system**
*Condotta barre prefabbricato***To which this declaration relates is in conformity with the following standard:***L'oggetto di questa dichiarazione è conforme ai seguenti standard o normative:***Standard / Norme:**CEI 17/13-1-2
CEI EN 61439
CEI EN 61000-2-4 (CEI 110-27)
DIN VDE 0660 parte 500-502
CEI EN 60068-2-11:2000 Class
CEI 104-17-F.5890**Type tests / Prove di Tipo**

1. Temperature-rise limits
2. Dielectric properties
3. Short-circuit strength
4. Effectiveness of the protective circuit
5. Clearances and creepage distances
6. Mechanical operation
7. Degree of protection
8. Electrical characteristics
9. Structural strength
10. Crushing resistance
11. Resistance to flame propagation
12. Fire barrier in building penetration

1. Tenuta alla tensione applicata
2. Limiti di sovratemperatura
3. Efficienza del circuito di protezione
4. Tenuta al cortocircuito
5. Cablaggio, funzionamento elettrico
6. Grado di protezione
7. Funzionamento
8. Distanze in aria e superficiali
9. Isolamento
10. Resistenza di isolamento
11. Misure di protezione
12. Barriera tagliafuoco

Date of issue / Data
12/05/2015

NAXSO S.r.l.



GOST CERTIFICATION



АНСР

СИСТЕМА СЕРТИФИКАЦИИ ГОСТ Р ГОССТАНДАРТ РОССИИ

СЕРТИФИКАТ СООТВЕТСТВИЯ

№	Наименование	Ссылка на стандарт	Ссылка на документ	Ссылка на документ	Ссылка на документ
1
2
3
4
5
6
7
8
9
10